

# SD Compressor Service Guide

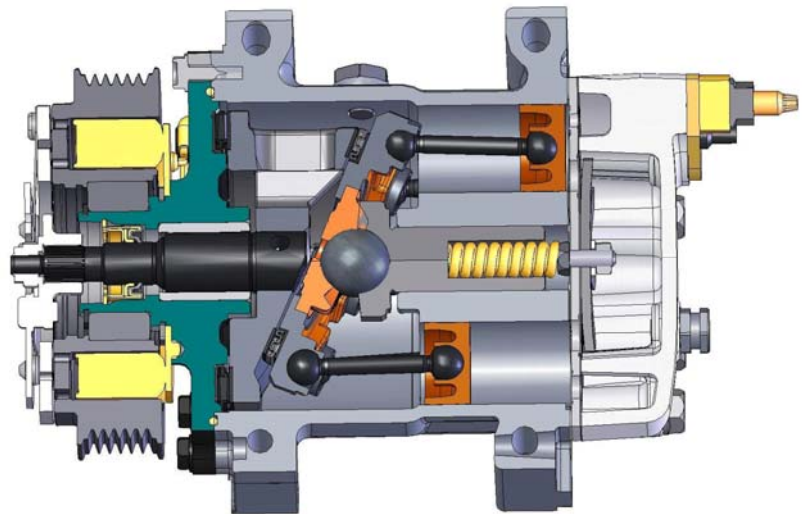

# **Table of Contents**

---

1. Compressor Models Covered
2. Compressor Nomenclature
3. Cautionary Information
  - 3.1 Pressure Release
  - 3.2 Recovery of Refrigerant
  - 3.3 Handling of Refrigerant
  - 3.4 Ventilation
  - 3.5 Avoid use of
  - 3.6 Warranty for Recycled Refrigerant
4. R134a Information
  - 4.1 R134a/PAG Oil Handling
  - 4.2 Table of Saturation Temperatures and Pressure
5. Compressor Identification
  - 5.1 Label
  - 5.2 Date Codes
6. Application Specifications
  - 6.1 Belt Tension
  - 6.2 Speed Rating
  - 6.3 Basic Specifications
  - 6.4 Assembly Torques
  - 6.5 Mounting
    - 6.5.1 Compressor Rotation
    - 6.5.2 Ear Deflection Bending
  - 6.6 Recommended Pressure and Temperature Conditions
    - 6.6.1 Discharge Gas Condition
    - 6.6.2 Suction Gas Condition
    - 6.6.3 Ambient Temperature
  - 6.7 Clutch
  - 6.8 Oil Charge
    - 6.8.1 Oil Flow Theory
    - 6.8.2 Oil Charging
      - 6.8.2.1 Passenger Car Light Duty Truck Single Evaporator
      - 6.8.2.2 Dual Evaporator Long Hose Systems
      - 6.8.2.3 System Refrigerant charges greater than 56 oz (1600g)
7. Diagnosis Confirmation Of Compressor Failure
  - 7.1 Compressor Rotation
  - 7.2 Clutch Inspection
    - 7.2.1 Voltage Test
    - 7.2.2 Air Gap Test
    - 7.2.3 Coil Resistance Test
  - 7.3 Pressure or Pumping Test
  - 7.4 Leak Checking
    - 7.4.1 Visual
    - 7.4.2 Soap bubble
    - 7.4.3 Electronic
    - 7.4.4 Dyes
  - 7.5 Noise
    - 7.5.1 Non Compressor
    - 7.5.2 Compressor

- 8. Compressor Repair
  - 8.1 Clutch Removal
  - 8.2 Clutch Installation
  - 8.3 Cylinder Head Replacement
- 9. Compressor Replacement
  - 9.1 Contamination Inspection
  - 9.2 Oil Amount (No Contamination)
  - 9.3 Oil Amount (Flushed System)
- 10. Service Procedures
  - 10.1 Flushing
    - 10.1.1 Equipment types
    - 10.1.2 Safety
    - 10.1.3 Acceptable Flushing Fluids
    - 10.1.3 Components to Flush
    - 10.1.4 Flushing Tips
    - 10.1.5 Removal of Residual Flushing Fluid
  - 10.2 Evacuation
  - 10.3 Refrigerant Charge
    - 10.3.1 Charging Systems
    - 10.3.2 High Side Charging
    - 10.3.3 Low Side Charging
  - 10.4 System Oil Balance
    - 10.4.1 Oil flow
    - 10.4.2 In Laboratory Oil Amount Determination
    - 10.4.3 Oil Checking is Not Required Under Normal Conditions
    - 10.4.4 Circumstances When Oil Addition or Balancing is Required
    - 10.4.5 Oil Addition during Component Replacement
- 11. Warranty
  - 11.1 Return Process
  - 11.2 Warranty Duration
- 12. Compressor Failure Causes
  - 11.1 Overheating
  - 11.2 Contamination
  - 12.3 Clutch Slippage
  - 12.4 Handling or Impact Damage
- 13. Tools
  - 13.1 Special Service Tools
  - 13.2 Standard Tools

## 1.0 Compressor Models Covered

Type	R-134a	R-12
7 Cylinder	SD7B10	SDB-706
	SD7H13	SD-708
	SD7H15/ HD, SHD	SD-709
5 Cylinder	SD7B10 / SD5H09	SD-505
	SD5H11	SD-507
	SD5H14	SD-508
		SD-510

## 2.0 Compressor Nomenclature

### R-134a

SD 7 H 15 HD

SD	7	H	15	HD
Sanden wobble plate piston type compressor	Number of pistons	Port Location B- Body H- Head	Approximate Displacement In CC's divided by 10	HD- Heavy Duty SHD- Sealed HD

### R-12

SD-709

SD	7	09
Sanden wobble plate piston type compressor	Number of pistons	Approximate Displacement In Cubic Inches

## 3.0 Cautionary Information

---

### 3.1 Pressure Release

- Before disconnecting any lines or removing the oil plug, always make sure refrigerant has been removed from the A/C system by recovering it with the appropriate recovery equipment.
- When working on compressors, separate from the system, always be sure to relieve internal pressure first. Internal compressor pressure can be relieved by removing shipping caps / pads from both ports.

### 3.2 Recovery of Refrigerant

- Never discharge refrigerant to the atmosphere. Always use approved refrigerant recovery / recycling equipment to capture refrigerant which is removed from the A/C system. Do not mix refrigerants in the same piece of equipment; one should be designated for R-12 and another for R-134a.

### 3.3 Handling of Refrigerant

- Always wear eye and hand protection when working on an A/C system or compressor. Liquid refrigerant can cause frostbite and / or blindness.

### 3.4 Ventilation

- Keep refrigerants and oils away from open flames. Refrigerants can produce poisonous gasses in the presence of a flame. Work in a well-ventilated area.

### 3.5 Avoid Use of Compressed Air

- Do not introduce compressed air into an A/C system due to the danger of contamination.

### 3.6 Warranty for Recycled Refrigerant

- The warranty offered by Sanden International (U.S.A.), Inc., on air conditioning compressors when used with recycled refrigerant will be the same as for new refrigerant provided that the following SAE standards are met:

	R-12	R134a
Refrigerant Purity	J1990	J2099
Recycling Machine	J1989	J2210, J2788

**Note:**

Recycling machines must be validated to the appropriate SAE standard and by Underwriters Laboratories. Recycled refrigerant from other sources must meet the appropriate ARI standards. Failure to comply with these provisions may void any warranty on the compressor.

## 4.0 R-134a Information

### 4.1 R134a / PAG Oil Handling Precautions

As a conscientious member of the global community, Sanden Corporation is committed to the elimination of CFC-based refrigerants. This manual focuses on service information for Sanden compressors intended for use with R134a and PAG oils.

1. Always follow safety precautions described in section 3.0
2. Do not discharge R134a into the atmosphere. Even though its ozone depletion potential is zero, it does have global warming potential. Recovery and recycling are mandated by the Clean Air Act. Use recovery equipment designated only for R134a. Never introduce another refrigerant into the R134a equipment.
3. Never mix R134a with other refrigerants or A/C systems failure may occur.
4. Use only Sanden specified PAG lubricants for R134a systems using Sanden compressors. If other lubricants are used, A/C system failure is likely to occur.
5. The Sanden specified PAG oils used in R134a systems absorb atmospheric moisture very quickly. Moisture in the A/C system can cause major damage or failure.
  - Never leave PAG oil exposed to air for a prolonged time. Tightly reseal the oil container immediately after each use.
  - During A/C system repair, cap all fittings as soon as opened and leave capped until just before they are reconnected.
  - If a repair is performed on an R134a compressor or system, evacuate the system for at least 30 minutes before recharging to ensure the removal of moisture which may have been absorbed by the PAG oil in the compressor and system.

### 4.2 Table of Saturation Temperatures and Pressures (R-134a)

Temp. (F)	Pressure (psig)	Temp. (F)	Pressure (psig)	Temp. (F)	Pressure (psig)
-40	-7.2 in. Hg	25	22	105	135
-30	-4.8 in. Hg	30	26	110	147
-20	-1.7 in. Hg	40	35	115	159
-15	0	50	45	120	172
-10	2	60	57	130	200
-5	4	70	71	140	231
0	6	80	85	150	264
5	9	85	95	160	301
10	12	90	104	180	386
15	15	95	114	200	485
20	18	100	124	210	549

## 5.0 Compressor Identification

### 5.1 Label

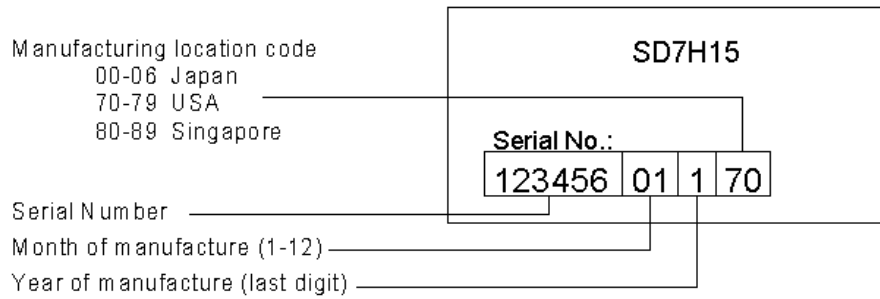

### 5.2 Manufacturing Date Codes Stamped on Compressor - Manufactured in USA Only

Manufacturing date codes are stamped on the mounting e or boss at the front left of the compressor as seen when facing the clutch, with oil plug or adaptor up.

Year of manufacture (first digit):  
 (i.e. 3 indicates manufacture in 1993)  
 Month of manufacture (last digit):  
 Jan. - Sept.: 1 - 9  
 Oct.: X  
 Nov.: Y  
 Dec.: Z

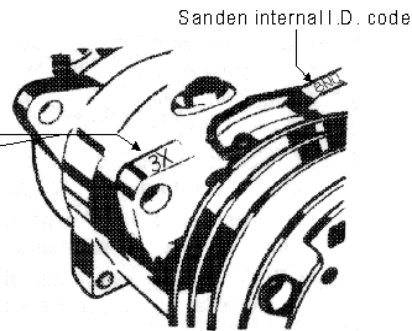

## 6.0 Application Specifications

### 6.1 Belt Tension

Note: These specifications are guide lines. When developing new HVAC systems it's recommended to consult your compressor supplier for application specifics.

Grooves	Tension, lb (kgf)
A	121 ± 5 (55 ± 2)
B	132 ± 5 (60 ± 2)
C	132 ± 5 (60 ± 2)
M	132 ± 5 (60 ± 2)
PV4	132 ± 5 (60 ± 2)
PV6	198 ± 5 (90 ± 2)
PV8	264 ± 5 (120 ± 2)

### 6.2 Speed Rating

Model	Clutch Type	Max RPM	
		Constant	Downshift
SD5H14	Std.	6,000	7,000
SD5H14	HD	4,000	6,000
SD7B10	All	6,500	9,300
SD7H13	All	6,000	8,000
SD7H15	All	6,000	8,000
SD7H15	Sealed HD	4,000	4,000
ESD7H15	All	4,000	6,000

### 6.3 Basic Compressor Specifications

Model	Refrigerant	Displacement cu.in. (cc)	Typical Weight, lb. (kg.)			Rotation
			Compressor	Clutch	Assembly	
SD5H09	R134a	5.3 (87)	7.9 (3.6)	4.3 (1.9)	12.3 (5.6)	CW only
SD5H11	R134a	6.6 (108)	10.2 (4.6)	4.6 (2.1)	14.8 (6.7)	CW only
SD5H14	R134a	8.4 (138)	11.2 (5.1)	6.0 (2.7)	17.2 (7.8)	CW only
SD7B10	R134a	6.1 (100)	5.9 (2.7)	3.3 (1.5)	9.2 (4.2)	CW only
SD7H13	R134a	7.9 (129)	9.3 (4.2)	4.6 (2.1)	13.9 (6.3)	CW only
SD7H15/HD	R134a	9.5 (155)	9.9 (4.5)	5.3 (2.4)	15.2 (2.4)	CW only
SD7H15/SHD	R134a	9.5 (155)	9.9 (4.5)	7.7 (3.5)	17.6 (8.0)	CW only

### 6.4 Assembly Torques

Item	ft - lb	N - m	kgf - cm
Armature retaining nut, 1/2" - 20	22.4 ± 2.9	30.4 ± 3.9	310 ± 40
Armature retaining nut, M8	13.0 ± 2.2	17.7 ± 2.9	180 ± 30
Cylinder head bolts, M6	10 ± 2.2	13.7 ± 2.9	140 ± 30
Cylinder head bolts, M8	25.3 ± 3.6	34.3 ± 4.9	350 ± 50
Oil filler plug	14.5 ± 3.6	19.6 ± 4.9	200 ± 50
Hose fitting 1" - 14 rotolock	26.7 ± 2.9	36.3 ± 3.9	370 ± 40
7/8" Tube-O	23.9 ± 2.9	32.4 ± 3.9	330 ± 40
1-1/16" Tub-O	30 ± 3	40 ± 4	414 ± 41
7/8" Flare	54.9 ± 2.5	74.6 ± 3.4	760 ± 35
3/4" Tube - O	17.3 ± 2.5	23.5 ± 3.4	240 ± 35
3/4" Flare	37.6 ± 1.4	51.0 ± 2.0	520 ± 20
Pad fitting bolt, M10	28.9 ± 2.9	39.2 ± 3.9	440 ± 40
Pad fitting bolt 3/8" -24	28.9 ± 2.9	39.2 ± 3.9	440 ± 40
Pad fitting bolt, M8	26.3 ± 2.9	34.3 ± 3.9	350 ± 40
Clutch lead wire clamp screw	11 ± 3 in•lb	1.3 ± 0.3	13 ± 3
High pressure relief valve	7.2 ± 1.4	9.8 ± 2.0	100 ± 20
Thermal protector switch clamp bolt	7.2 ± 2.2 - 1.4	9.8 ± 2.9 - 2.0	100 ± 30 - 20
Clutch dust cover screws (6 - M5)	6.5 ± 1.4	9 ± 2	90 ± 20
Clutch dust cover screws (3 - 1/4" - 20)	2.7 ± 0.9	3.6 ± 1.2	37 ± 12

### 6.5 Mounting

#### 6.5.1 Compressor Rotation

Compressor can be rotated 90° clock wise or counter clockwise keeping the oil fill plug above the 3:00 or 9:00 positions.

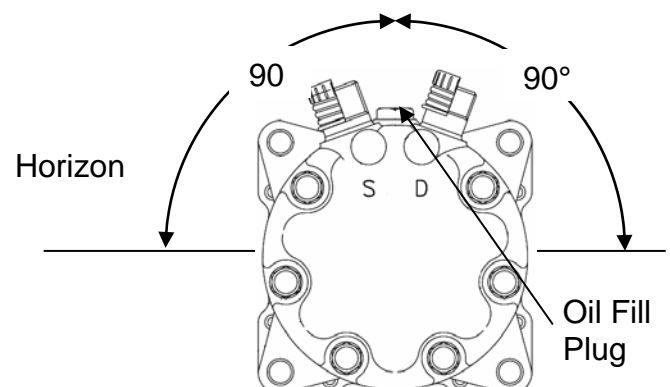



## 6.5.2 Mounting Ear Deflection

Compressor Model		A=Distance Between Ears
SD505	SD5H09	67mm
SD507	SD5H11	73.3 mm
	SD7H13	
SD508	SD5H14	83.3 mm
SD709	SD7H15	
SD510		

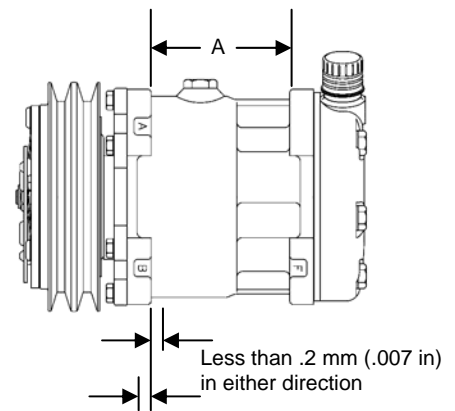

- Total combined ear deflection or bending cannot exceed .4 mm (.016 in) or .2 mm per ear. Mounting brackets allowing extreme ear bending will cause gaskets to leak refrigerant leak.

## 6.6 Recommended Pressure and Temperature Conditions

### 6.6.1 Discharge gas conditions

- Short term peak: 430 psig max. (short idle or short acceleration time)
- Limited term: 400 psig max. (extended idle or short acceleration time)
- Long term continuous: less than 300 psig. Up to 4000 rpm (for optimum life)
- Max continuous temperature: 280 deg. F (300 F short term)

### 6.6.2 Suction gas conditions

- Minimum continuous: 6 psig (up to 4000 rpm for optimum life)

### 6.6.3 Ambient Temperature

- Non operational: above -40°F and below 250°F
- In operating mode the compressor should be above 32 deg F. and below 200 Deg F. Please note that in high ambient temperatures (near turbo charger or exhaust manifold) heat is absorbed by the compressor, this added heat must be rejected by the condenser. High heat conditions can negatively affect sealing elastomers at hose connections. Effort should be taken to keep the compressor as cool as possible for maximum durability.

## 6.7 Clutch

- Clutch Cycling rate: less than 4 cycles per minute
- Clutch Voltage: Greater than 11.5 VDC for 12VDC systems
- Clutch Voltage: Greater than 23 VDC for 24 VDC systems
- Power Draw: 49 watts at 12 & 24 Volts

## 6.8 Oil Charge

- Oil Circulation Ratio (OCR) should be between 3.3% and 8% ratio of oil to refrigerant by weight.

## 6.8.1 Oil Flow Theory

- Compressor lubrication occurs as the oil which circulates with the refrigerant passes through the compressor crankcase during operation. The Sanden SD series compressor achieves optimal durability and cooling performance when oil circulates through the system at a ratio of 3.3% to 8% oil to refrigerant. Excess oil can act as an insulator limiting heat transfer in the evaporator and condenser, while too little oil can negatively affect durability.
- Oil will collect in low pressure cool components (evaporator, accumulator and suction hose) of the refrigerant loop. For example a long suction hose which sags can collect several ounces thus reducing overall oil circulation ratio.

## 6.8.2 Oil Charging

### 6.8.2.1 Passenger Car, Light Duty Truck Single Evaporator

Refrigerant charges 24oz (680g) to 40oz (1133g)

- 135cc oil TXV systems
- 240 cc oil in orifice tube systems

### 6.8.2.2 Dual Evaporator Long Hose Systems

Less than 56oz or 1600g of refrigerant charge

1. The desired oil charge for the systems with unusually long hoses, such as trucks, tractors, etc., can be determined based on the total refrigerant charge when less than 56 oz. (1600g) refrigerant is used.
2. Calculate the desired oil charge as below:

Oil amount (oz.) = [(Refrigerant charge in oz. x 0.06) + 2.2] ÷ 0.9.

Oil amount (cc) = [(Refrigerant charge in grams x 0.06) + 66] ÷ 0.9.

Note: For systems with very long hose runs add an additional 1.0 oz (30cc) of oil for each 10 foot of hose plus an additional 1.1 oz (33cc) as a safety measure.

Long Hose Example:

A system w/ a 32oz refrigerant charge and 11ft long suction hose:

$$\begin{array}{ccc} \text{Refrigerant Charge} & & \text{Suction Hose Length} \\ \hline \text{Oil charge} = & \left[ \frac{[(32\text{oz} \times 0.06) + 2.2]}{0.9} \right] + & \left[ (1\text{oz}/10\text{ft} \times 11\text{ft}) \right] \times 1.1 \text{ safety factor} \\ & = 4.6 \text{ oz} + 2.2 \text{ oz for total of } & 6.8 \text{ oz} \end{array}$$

3. For a new compressor to be used in this type of system, subtract the delivered oil amount from the desired total oil charge to determine how much oil should be added to the compressor and system.

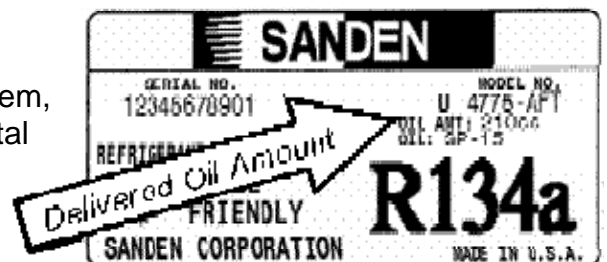

4. Remove the oil filler plug and charge the compressor with the amount of additional oil determined in step 3. Use only new oil of the correct type as shown on the compressor label. If calculated amount is greater than 300cc (10oz) oil can be added to other system components.
5. Re-install oil plug. Seat and O-ring must be clean and not damaged. Torque to 11-18 ft•lb (15-25 N•m, 150-200 kgf•cm).

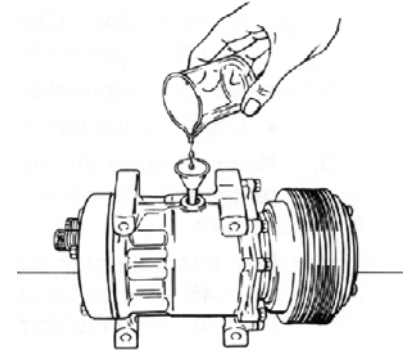

### 6.8.3 Systems Refrigerant Charge Greater Than 56 oz. (1656 g) of Refrigerant

1. Charge system with refrigerant.
2. Set up the vehicle as follows:
  - a. Doors open
  - b. Maximum blower speed
  - c. Ambient temp. at least 75°F (24°C).
3. Run the compressor at one of the speeds listed in the table in section 6.8.3 step 11.

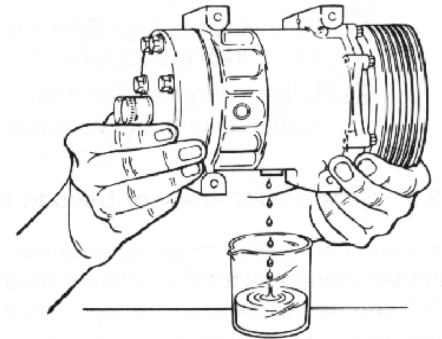

4. While maintaining engine speed, turn off A/C system and immediately turn off engine.
5. Recover refrigerant from the system.
6. Remove compressor from vehicle.
7. Remove the oil plug and drain as much oil as possible into a suitable container.
8. Drain oil from the suction and discharge ports into a suitable container while turning the shaft clockwise only with a socket wrench on the armature retaining nut.
9. Measure and record the volume of the oil drained from the compressor.

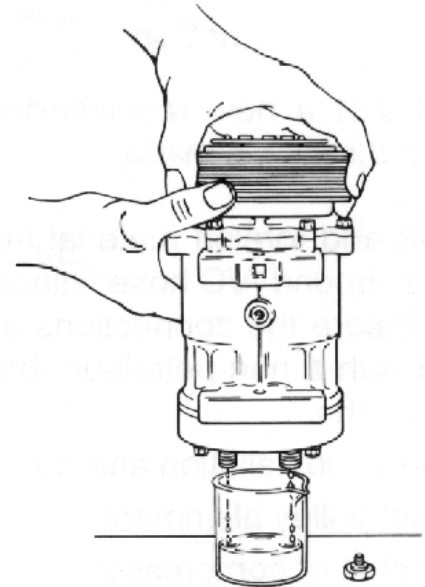

10. Approximately 0.5 fl.oz. (15cc) will remain in the compressor as a film coating the internal surfaces. Add 0.5 fl.oz. (15cc) to the recorded volume of the oil. This is the calculated amount of oil in the compressor.

11. The amount of oil in the compressor after running for 10-15 minutes should be as per the table at right. Determine from the table what the correct amount of oil should be for the particular speed used in step 3. (The table shown applies to SD5H14 and SD7H15 compressors. It is important that a quantity of oil remains in the crankcase

Compressor RPM	Oil In Compressor	
	fl oz	cc
1,000	3	89
2,000	2.5	73
3,000	1.7	44
4,000	1.3	38
5,000	1.2	35

after the test.)

12. Compare the desired amount of oil as determined in step 11 with the calculated actual amount of oil in the compressor, determined in step 10. If the amount of oil actually in the compressor [amount drained plus 0.5 fl.oz. (15cc)] is less than the desired amount of oil, add oil as necessary to the container and pour back into the compressor, If the amount of oil actually in the compressor is too much, remove oil from the container until the correct amount is reached. Use the correct oil type as per Section 6.3.

*Note: If results of step 12 show more oil is required add more than the difference between table amount and actual. The reason is that the additional amount will be distributed throughout the entire system once the system is started. Repeat steps 11 and 12.*

- Vehicle Open Doors
- Blower Maximum Speed
- Ambient Temperature minimum 75°F

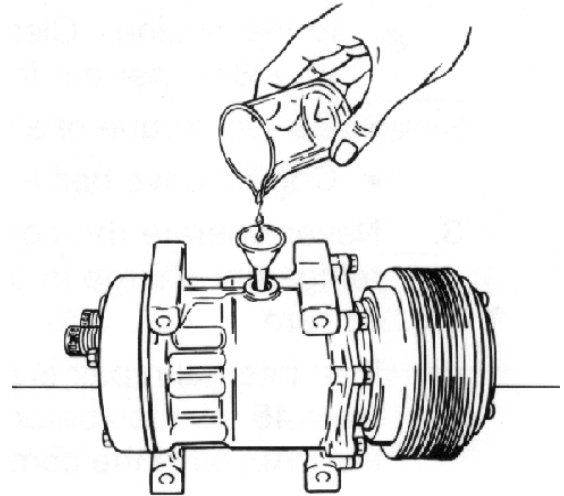

13. Re-install oil plug. Seal and O-ring must be clean and not damaged. Torque to 11-15 ft•lb (15-20 N•m, 150-200 kgf•cm).

## 7. Diagnosis Confirmation of Compressor Failure

- The compressor is the most expensive component in the A/C system loop. Steps 7.1 through 7.4 should be used to determine if the compressor is functioning correctly or not and prevent removal of a good compressor.

### 7.1 Compressor Rotation Test

- Most internal compressor failures can be quickly identified by performing a shaft rotation test. Normal rotation of the compressor shaft should be smooth without catching or binding.
- Compressors which bind or hang during the shaft rotation test have an internal part which is broken or contamination preventing compressor operation. This compressor should be removed and replaced with a new unit.

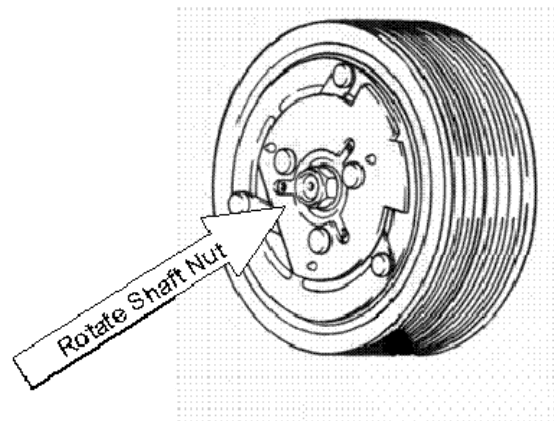

## 7.2 Clutch Inspection

### 7.2.1 Voltage Check

1. Confirm that the clutch is receiving at a minimum 11.5 V or 23 V for 12 V and 24 V systems respectively. If voltage is not being received at the clutch run a diagnostic on the vehicle electrical system. (Note: perform test with power applied to coil to fully load the circuit)
2. Pulley or Rotor Spin Check
3. With clutch disengage the pulley should spin freely with no wobbling or roughness/vibration

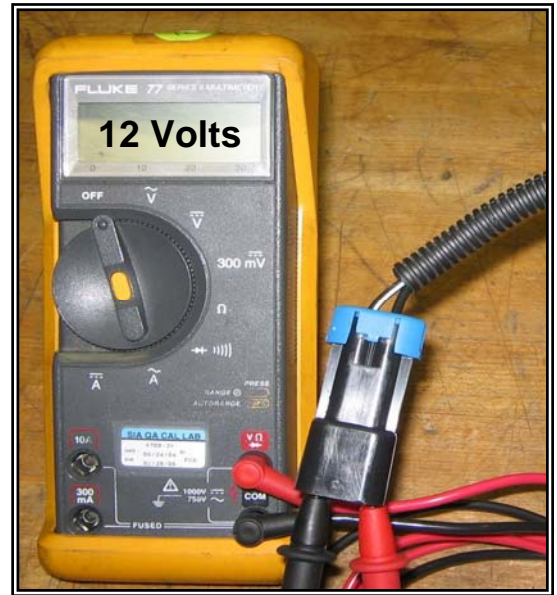

### 7.2.2 Air Gap Check

1. Air gaps exceeding 0.051" (1.3 mm) can prevent engagement. This often is noticed after the clutch and compressor temperature is heated through normal use. Refer to section 8.2.6 for more information setting correct gap.

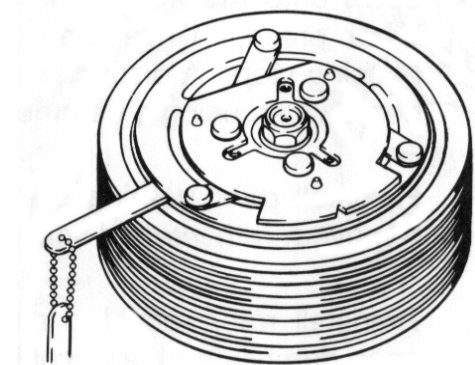

### 7.2.3 Resistance Check

1. Field coils with internal shorts can be tested by measuring resistance across the field coil. Resistance should fall within these values.
  - 12 Volt coil resistance should measure between 2.8  $\Omega$  and 4.4  $\Omega$  @ room temperature
  - 24 Volt coil resistance should measure between 14  $\Omega$  and 18.2  $\Omega$  @ room temperature



## 7.3 Pressure or Pumping Test

- Compressors cause refrigerant to flow through the system by creating a pressure differential, high and low pressures. If the compressor can be forced to produce a high pressure in excess of 350 psig it is a good compressor.

**Important: This test must be performed with a full system charge! Confirm the system is charged per the OEM requirement before proceeding.**

- Disconnect electric engine cooling fan and bypass high pressure cut off switches. The condenser can also be blocked with sheet of card board. The purpose is to limit heat removal from the system and build compressor discharge pressure.
- Start engine and engage clutch
- Compressors operating within specification should be capable of reaching 350 psig.

**Important: This test should only be run for a short time period. Shut the system down immediately once 350 psig is achieved**

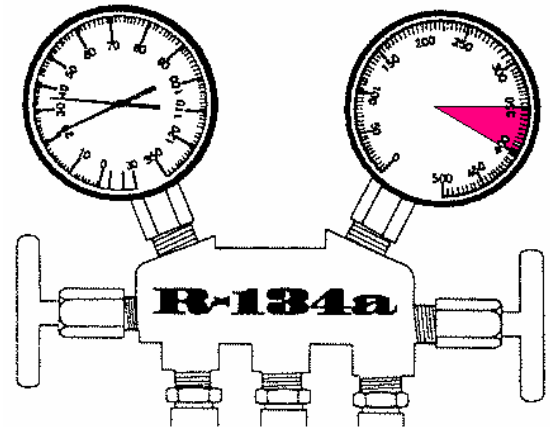

## 7.4 Leak Checking

### 7.4.1 Visual Inspection

Although oil seepage does not necessarily indicate leakage of refrigerant, it should be considered a sign that a leak may exist. Look for the following items:

- Oil seepage in shaft seal area (between clutch and compressor) - repairable.
- Pinching or extrusion of front housing O-ring – non-repairable.
- Oil around cylinder head (gaskets, service valves, fittings) - repairable.
- Oil around oil plug - repairable.
- Stripped threads – non-repairable.
- Oil around crack in compressor body – non-repairable.

### 7.4.2 Soap Bubble Detection

- Soap bubbles are a means to detect gross leaks. In general one very small bubble released per second is equal to 40 oz of refrigerant loss per year. Finding leaks smaller than 40 ounces per year requires an electronic detector.

### 7.4.3 Shop Type Electronic Detectors

- Ensure that the detector being used is sensitive to R134a refrigerant. Many leak detectors intended for R-12 cannot detect R134a leaks. Use the leak detector in accordance with the manufacturer's instructions. The leak rate at any portion of the compressor should not exceed 1.0 oz./yr. Make sure that a suspected leak is an actual flow of refrigerant, not a small pocket of refrigerant trapped in a recess. Cleaning the suspect area with soap and water (never a solvent) or blowing off the area with compressed air can help confirm a suspected leak. Leak check procedures should be in accordance with SAE J1628. Electronic leak detectors meeting SAE J2791 are sensitive enough to detect 1/7<sup>th</sup> oz per year leak rates.

#### **7.4.4 Leak Detection Dyes**

- Leak detection dyes are to be used in accordance with the manufacturer's instructions. Many OEM's now install dye during vehicle assembly so it may not be necessary to add additional dye when inspecting for leaks. Consult OEM documentation to confirm presence of dye before adding dye to the system.
- Leak detection dyes work by staining the system oil. So when adding dye to a system which did not initially contain dye the system will need to operate for some time to allow all the oil to become stained and arrive at the leak.

### **7.5 Noise**

#### **7.5.1 Unusual Noise Not due to Compressor**

Unusual noises may be caused by components other than the compressor

Compressor Mounting - Check for:

- Loose belt - see belt tension specifications.
- Broken bracket or compressor mounting ear. Replace broken component.
- Missing, broken, or loose mounting bolts. Replace, reinstall, or tighten.
- Flush fit of compressor to bracket and vehicle engine. Replace any part not properly fitted.
- Loose or wobbling crankshaft pulley. Check for damage to pulley, incorrect center bolt torque or center bolt bottoming. Repair to vehicle manufacturer's specifications.
- Bad idler pulley bearing. Replace if necessary.

#### **7.5.1 Unusual Noise Not due to Compressor - Continued**

Other Engine components - Check for noise in:

- Alternator bearing
- Air pump (if present)
- Water pump bearing
- Valves
- Timing belt or chain
- Power steering pump (if present)
- Loose engine mount bolts
- Idler pulley for automatic belt tensioning

## 7.5.2 Unusual Noises Due to Compressor

- Suction pressure less than about 6 psig can cause unusual noise. Charge refrigerant to proper amount and test by applying heat to evaporator to increase suction pressure.
- Clutch bearing
- Oil level--insufficient oil can cause unusual noise. *See Oil Charge in Section 6.8 .*
- Compressor suction or discharge valve breakage will cause a clacking sound at idle.
- If head gasket failure occurs, discharge pressure will be low and suction pressure will be high at idle.

## 8.0 Compressor Repair

### Clutch Components

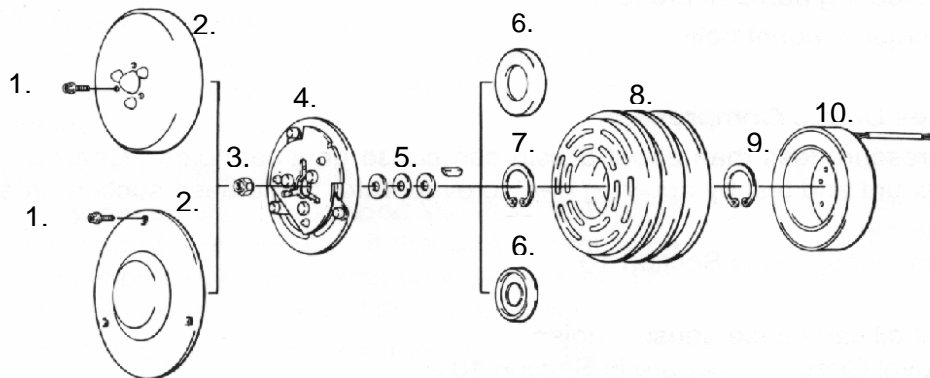

1. Armature dust cover screw	4. Armature plate	7. Pulley & Bearing Snap Ring	10. Field Coil
2. Armature dust cover	5. Clutch Shims	8. Pulley & Bearing Assembly	
3. Shaft nut	6. Rotor Bearing Dust Cover	9. Field Coil Snap Ring	

### 8.1 Clutch Removal

#### 8.1.1 Armature Nut-Removal

1. If armature dust cover is present, remove the 3 or 6 bolts holding it in place and remove cover. If auxiliary sheet metal pulley is present, remove the screws holding it in place. Then remove pulley.
2. Insert pins of armature plate spanner into threaded holes of armature assembly.
3. Hold armature assembly stationary while removing retaining nut with 3/4", 19mm or 14mm socket wrench, as appropriate.

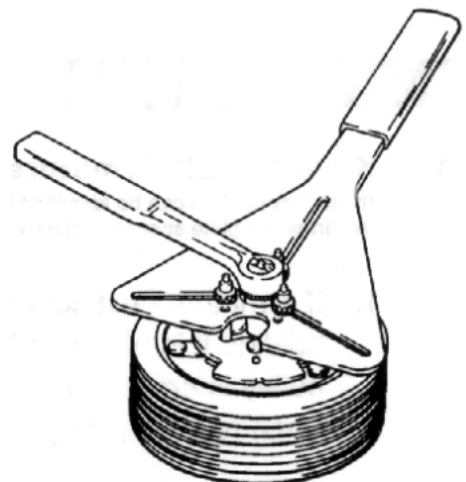



### 8.1.2a Key Shaft Armature-Removal

4. Remove armature plate assembly using puller. Thread 3 puller bolts into the threaded holes in the armature assembly. Turn center screw clockwise until armature assembly comes loose.

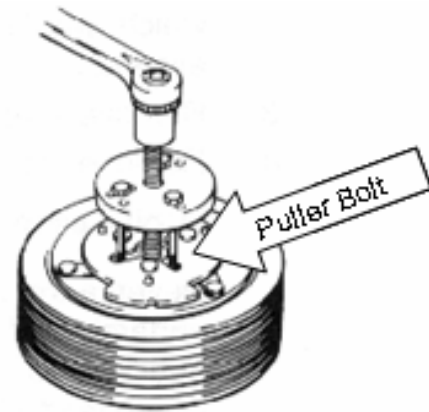

### 8.1.2b Spline Shaft Armature-Removal

5. The spline shaft armature will not have threaded holes to accept the armature puller
6. Lift off armature plate with fingers. If armature does not come off easily, spray an anti seizes oil into shaft to loosen. Armature plate can also be loosened by gently prying between rotor and armature plate with two flat screwdrivers.

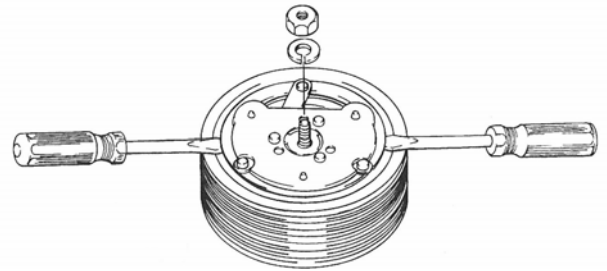
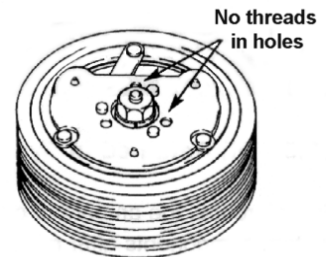

### 8.1.3 Remove Clutch Accessories

- Bearing Dust Cover (if applicable)
- Shaft Key (if applicable)
- Shims

### 8.1.4 Rotor Pulley Assembly Removal

1. Remove rotor snap ring.
2. Insert the lip of the jaws into the snap ring groove.
3. Place rotor pulley shaft protector (Puller set) over the exposed shaft.
4. Align thumb screws to puller jaws and finger tighten
5. Turn puller center bolt clockwise using a socket wrench until rotor pulley is free.

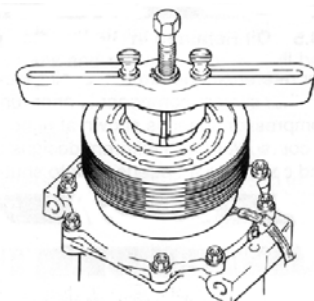
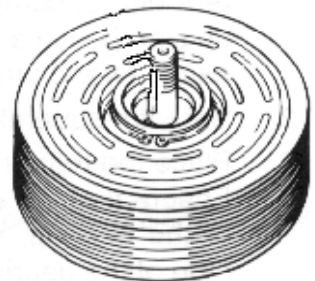

### 8.2.1 Field Coil Assembly Removal

1. Loosen lead wire clamp screw with #2 Phillips screw driver until wire(s) can be slipped out from under clamp.
2. Undo any wire connections on the compressor which would prevent removal of the field coil assembly.
3. Remove field coil snap ring
4. Remove the field coil assembly

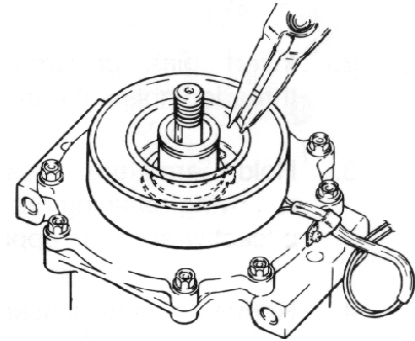

## 8.2 Clutch Replacement

### 8.2.1 Field Coil Assembly Installation

1. Reverse the steps of Section 8.2.1. Protrusion on underside of coil ring must match hole in front housing to prevent movement and correctly locate lead wire(s).

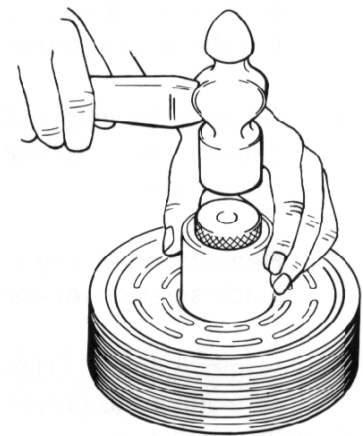

### 8.2.2 Rotor Assembly Installation

1. Place compressor on support stand, supported at rear end of compressor. If the compressor must be clamped in a vise, clamp only on the mounting ears, never on the body of the compressor.
2. Set rotor squarely over the front housing boss.
3. Place the rotor installer ring into the bearing bore. Ensure that the edge rests only on the inner race of the bearing, not on the seal, pulley, or outer race of the bearing.
4. Place the driver into the ring and drive the rotor down onto the front housing with a hammer or arbor press. Drive the rotor against the front housing step. A distinct change of sound can be heard when using the hammer to install the rotor.
5. Reinstall rotor retaining snap ring with external snap ring pliers. If a bevel is present on the snap ring, it should face up (away from the body of the compressor).
6. Reinstall rotor bearing dust cover (if present) by gently tapping it into place.

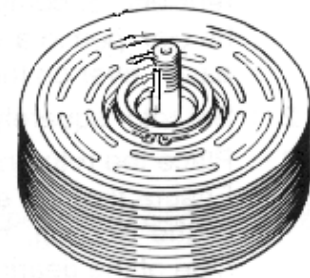

### 8.2.4 Armature Assembly Installation

1. Install clutch shims. NOTE: Clutch air gap is determined by shim thickness. When installing a clutch on a used compressor, try the original shims first. When installing a clutch on a compressor that has not had a clutch installed before, first try 0.04", 0.02", and 0.004" (1.0, 0.5, 0.1 mm) shims.

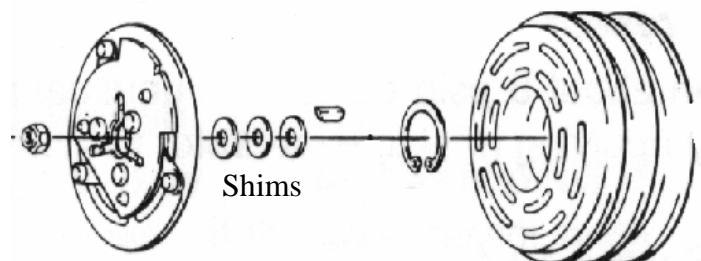

### 8.2.4a Keyed Shaft Only

1. Install shaft key with pliers.
2. Align keyway in armature assembly to shaft key. Using driver and a hammer or arbor press, drive the armature assembly down over the shaft until it bottoms on the shims. A distinct sound change will be noted if driving with a hammer.

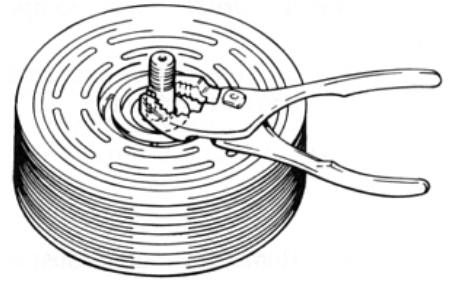

### 8.2.4b Spline Shaft Only

1. Align slot in armature with locator tooth on shaft. Press armature towards rotor with hand until armature rests against the shims.

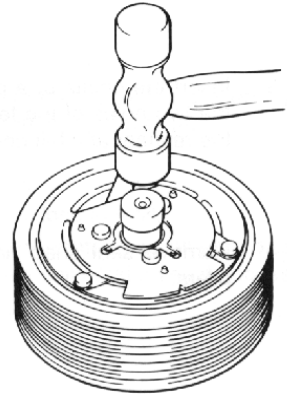

### 8.2.5 Armature Retaining Nut

1. Replace retaining nut and torque to specification. **1/2-20: 20-25 ft•lb (27-34 N•m, 270-350 kgf•cm) M8: 11-15 ft•lb (15-21 N•m, 150-210 kgf•cm)**

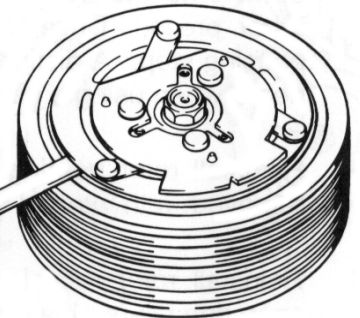

### 8.2.6 Air Gap Conformation

1. Check air gap with feeler gauge. Specification is 0.016" - 0.031" (0.4 - 0.8mm). If gap is not even around the clutch, gently tap down at the high spots.
2. If the overall gap is out of spec., remove the armature assembly and change the shims as necessary.
3. Replace armature dust cover (if used) and torque 3 or 6 bolts to specification below.
  - 1/4-20 bolts (SD-5): 2-4 ft•lb (2-5 N•m, 25-50 kgf•cm)
  - M5 bolts (SD-7): 5-8 ft•lb (7-11 N•m, 70-110 kgf•cm)

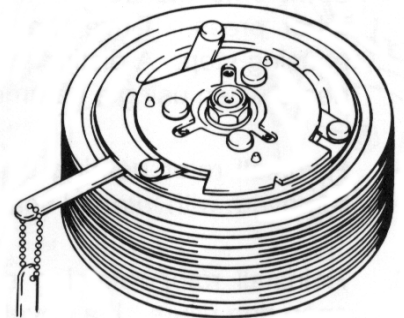

**\*Note: Over torque of SD508/SH14 dust cover bolts will cause air gap to become out of spec.**

## 8.3 Cylinder Head Replacement

### 8.3.1 Cylinder Head Removal

1. Be sure all internal compressor pressure has been relieved.
2. Inspect cylinder head for fitting or thread damage. Replace if damaged
3. Remove cylinder head bolts.
4. Use a small hammer and gasket scraper to separate the cylinder head from the valve plate. Be careful not to scratch the gasket surface of the cylinder head.

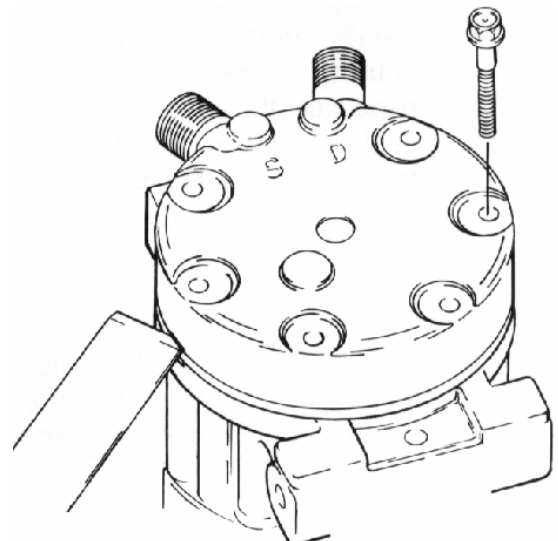

5. Carefully lift the cylinder head from the valve plate.
6. It is recommended that both the head gasket (between the cylinder head and the valve plate) and the block gasket (between the valve plate and the cylinder block) be replaced any time the cylinder head is removed. However, if no service is required to the valve plate, it may be left in place. If the valve plate comes loose from the cylinder block, the block gasket must be replaced.
7. Carefully remove old head gasket from top of valve plate with gasket scraper. Be careful not to disturb the valve plate to cylinder block joint if valve plate has been left in place. If valve plate comes loose from cylinder block, proceed to Section 8.3.2, Valve Plate Removal, and replace block gasket.

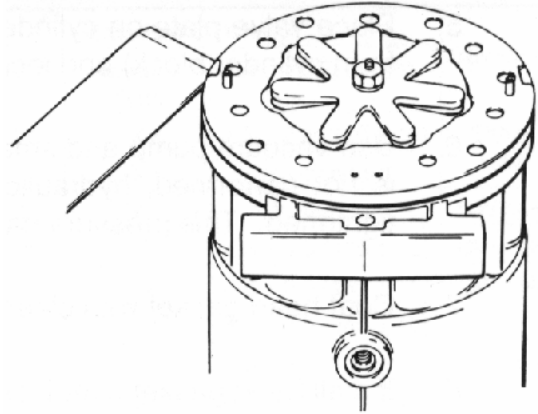

### 8.3.2 Valve Plate Removal

1. Using a small hammer and gasket scraper, carefully separate valve plate from cylinder block. Be careful not to damage sealing surface of cylinder block.
2. Inspect reed valves and retainer. Replace valve plate assembly if any part is damaged.
3. Carefully remove any gasket material remaining on valve plate, cylinder block or cylinder head. Do not damage sealing surfaces on components.

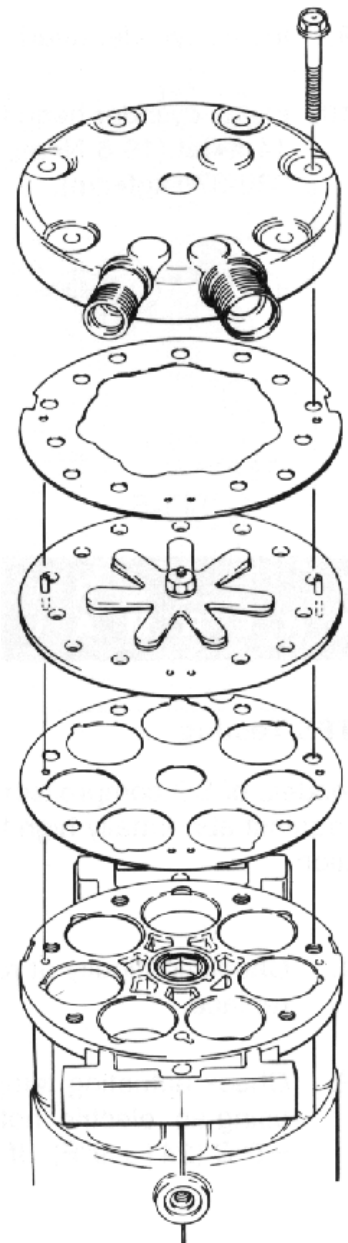

### 8.3.3 Valve Plate and Cylinder Head Installation

#### NOTE:

- Large gasket: OD of block gasket is 4-3/4" (120mm) and sealing face of block does not have a 4-1/2" (114.7mm) diameter step.
  - Small gasket: OD of gasket is 4-1/2" (114.7mm) and sealing face of the cylinder block has a 4-1/2" (114.7mm) diameter step.
1. Coat new block gasket with clean 5GS refrigerant oil.
  2. Install block gasket. Align new gasket to location pin holes and orifice(s). Notch (if present) should face same direction as oil plug or adaptor.
  3. Place valve plate on cylinder block with discharge valve, retainer and nut facing up (away from cylinder block) and location pins properly located in holes.
  4. Use vacuum pump and small tube to remove residual oil from each bolt hole. If this step is not performed, hydraulic pressure can be created when the cylinder head bolts are tightened. This pressure can break the cylinder block.
  5. Coat head gasket with clean 5GS refrigerant oil.
  6. Install head gasket cover location pins, checking for correct orientation.

7. Install cylinder head.
8. Install cylinder head bolts and tighten in a star pattern. Torque first to approximately 14 ft•lbf (19.6 N•m, 200 kgf•cm), then finish by torquing to 24-27 ft•lbf (32.4-36.3 N•m, 330-370kgf•cm).

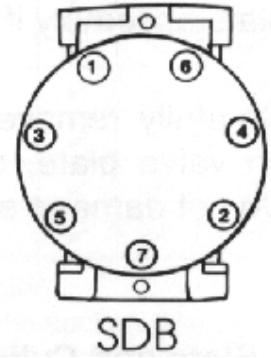
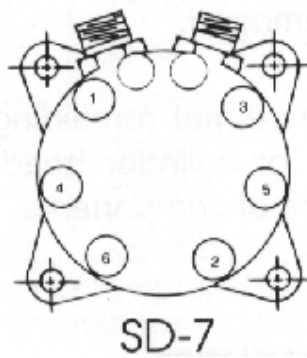
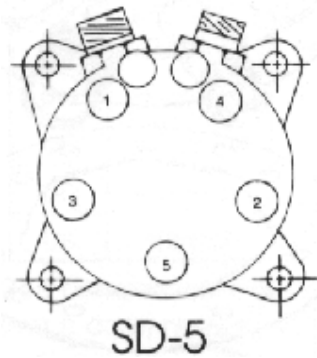

## 9.0 Compressor Replacement

- It's critical for successful compressor replacement that the new compressor is installed in a clean system with a correct oil charge. Contamination remaining in the system will be pulled into the new compressor and lodge under the valves and in bearings causing quick failure of the new compressor. Also it's important to maintain the original OEM oil charge amount when replacing the compressor.

### 9.1 Contamination Inspection

- Contamination from foreign material can be found by looking at the oil drained from either the compressor or the suction and discharge lines. Contamination can also be seen collecting in the orifice tube or expansion valve.



Example of contamination collected on inlet side of orifice tube requiring system flushing



Clean oil is clear or translucent

Contaminated oil with metal particles will require system flushing

Overheated oil is dark and will require flushing

- To illustrate how contamination will quickly wreck a good compress, the photo to the right shows a small metal shaving lodged under the discharge valve. The valve will open and close against the metal shaving resulting in a fatigue break of the valve. The broken valve is now free to travel inside the compress causing additional internal failures. Eventually the compressor will stop pumping and over heat.



Section 10.1 page 23 provides information on flushing practices

## 9.2 Oil Amount (Flushed System or New Systems)

- Systems which have no oil in them due to flushing or the system is being built from new components will require oil amounts in accordance with the OEM's requirement.

### Note:

- The factory oil charge in many passenger cars and heavy trucks can be found on the compressor label. Off highway or school bus applications often have the compressor amount plus additional oil for long hose application so be sure to consult the OEM procedures in these instances.

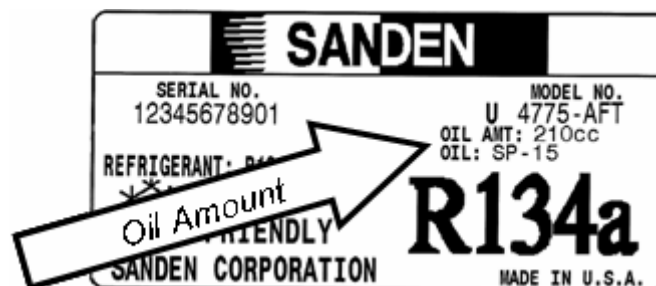

- Sanden service compressors are supplied with a full oil charge as indicated on the label above. This amount is consistent with the original OEM charge used during vehicle build.

## 9.3 Oil Amount (Compressor swap, no flushing)

- The goal of this procedure is to measure the oil amount in the failed compressor and adjust the amount in the new compressor to equal that of the failed. Section 10.2.5 has more information on system oil balance
1. Remove the oil plug from the failed compressor and drain as much oil as possible into a suitable container.
  2. Drain oil from the suction and discharge ports into a suitable container while turning the shaft clockwise only with a socket wrench on the armature retaining nut.
  3. Measure and record the amount of oil drained from the compressor.

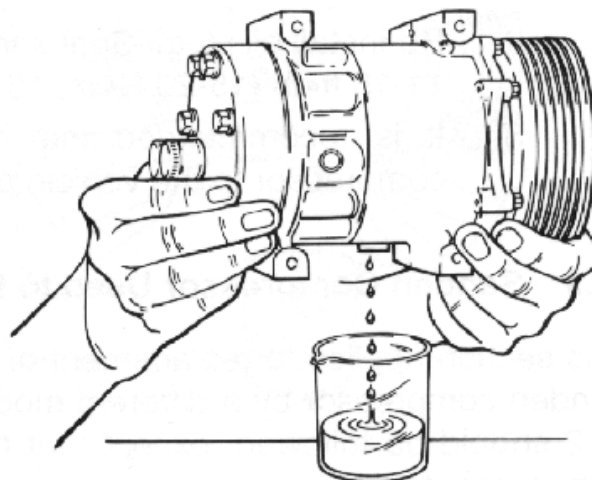

4. Drain oil from the new compressor following steps 1 and 2.
5. Add oil back into the new compressor in an amount equal measurement taken in step 3.
6. Re-install oil plug. Seal and O-ring must be clean and not damaged. Torque to 11-15 ft•lb (15-20 N•m, 150-200 kgf•cm). Be careful not to cross thread the oil plug.

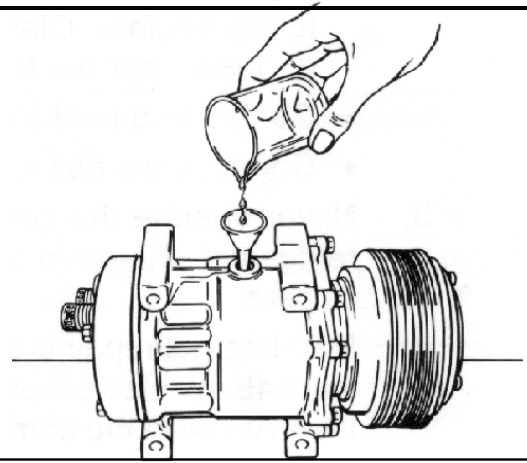

## **10.0 Service Procedures**

### **10.1.1 Flushing**

#### Equipment types

1. Refrigerant recovery recycle machines which contain a flushing circulating pump to solvent-clean using R134a.
2. A closed loop flushing machine in which the circulated flushing fluid is returned to a reservoir for filtering and continued circulation. Most of these machines provide a pulsing action to dislodge particles that are stuck in small passageways.
3. A pressurized flush gun with a pulsating spray can also be used. To use this technique, block one end of a AC system component being flushed in order to build pressure inside the component, and then quickly release the blockage to pulse the flushing solvent out.

#### Safety

- Do not use flammable fluids.
- Protect eyes with safety goggles.
- Wear chemical resistant gloves.
- Use approved fluids. CFCs R-11,113 or 115 and Methyl Chloroform also known as 1,1,1, Trichloroethane are not acceptable per the Clean Air Act.

### **10.1.2 Acceptable Flushing Fluids**

- Fluids designated for AC flushing should be used and may be either solvent or lubricant based. Fluids used to flush the system should meet SAE specification J2670 to insure compatibility with refrigerant, oil and any materials used in the A/C system.

### **10.1.3 Components to Flush**

- Flush hoses, hard lines and heat exchangers. DO NOT flush the compressor, accumulator or receiver drier, refrigerant lines with mufflers, thermal expansion valve or orifice tube because residual flushing fluid cannot be removed from these components and they restrict the flow of flushing agent through other components.

### **10.1.4 Why Suction Side Flushing Is Important**

- When the off-cycle pressure equalizes in the backwards direction through damaged compressor valves, debris may be forced back up the suction hose. If it is not removed, this debris will travel into the replacement compressor and be circulated through out the AC system, causing subsequent failures.

### 10.1.5 Flushing Rear Evaporator Lines

- Debris is distributed throughout the entire AC system so it is important to flush the rear lines. The rear expansion valve can be gutted or drilled out and remounted so that the rear evaporator and hoses can be back flushed as an assembly. After blowing out the flushing fluid and fumes a new thermal expansion valve should be mounted.

### 10.1.6 Importance Of Flushing Direction

- “Back flush”, or flushing in the reverse direction to normal flow, is the most effective. The plate fin evaporators used on many front and rear evaporators have many small passages which are difficult to clean without a strong pulsating reverse flow.

### 10.1.7 How long do I flush?

- Closed loop procedure, flush until the flushing fluid leaving the AC components are clean. Manual pressurized gun method requires a minimum of three times, but more if exiting fluid is not clean.

### 10.1.8 Removal of Residual Flushing Fluid before Evacuation and Charge

- The primary vacuum pump should be protected from flushing fluid and fumes. Purging of flushing solvent is necessary before connecting the recovery recycle machine to evacuate and charge the AC system. The best method is to allow Nitrogen to flow through the components. If Nitrogen is not available, clean and dried compressed air can be blown through the flushed components until the flush liquid is evaporated.

## 10.2 Evacuation

- Evacuation is the process of removing air and moisture from the refrigeration system before charging the system with refrigerant. Air or moisture remaining in the system before and during the refrigerant charge process will cause increased pressures during operation resulting in reduced or poor cooling and greatly reduce the compressor life.

### 10.2.1 Explanation of Evacuation

- As vacuum is increased the temperature at which water boils drops. As the water/moisture boils its vapor can be drawn out of the system by the vacuum pump. It is recommended to perform the evacuation process in a warm area. The vehicle engine can also be run in order to warm up the components of the A/C system to enhance the evacuation process.

Water Boils Under a Vacuum	
System Vacuum Inches Mercury	Boiling Point Degrees F
24.04"	140 F <sup>o</sup>
26.45"	120 F <sup>o</sup>
27.99'	100 F <sup>o</sup>
28.89"	80 F <sup>o</sup>
29.40"	60 F <sup>o</sup>
29.71"	40 F <sup>o</sup>
29.82"	20 F <sup>o</sup>
29.87"	5 F <sup>o</sup>



- Allow the vacuum pump to run for 30 minutes drawing down near to 30" Hg. After 30 minutes of evacuation close the service valves and turn off the pump. Let the system sit for 10 minutes, if vacuum loss of 2" or greater occurs there is probably a leak.
  - Other reasons a vacuum cannot be held for 10 minutes after shut off.
    - Flush was not completely removed from system before evacuation started.
    - Refrigerant is trapped in refrigerant oil from previous charge.

### 10.2.2 Vacuum Pump Service

- Vacuum pumps not receiving regular service will be unable to draw an adequate vacuum. In most cases simple changing the pumps oil will correct the problem. Be sure to follow the manufacturer's recommendations for any maintenance on your evacuation pump. Change the oil after use while the oil is still hot, because contaminants are still in suspension and will be removed with the oil. If contaminants cool, solidify and stay in the pump, they lower vacuum efficiency. In extreme cases, the oil stops lubricating and the pump seizes. The only way to determine oil condition is to test vacuum pulled with an electronic vacuum gauge. Contamination cannot be determined by oil color.

## 10.3 Charging the A/C System

### 10.3.1 Charging systems

- Electronic weight scales
- Charging stations



#### Safety Note

- ***Never open the high side service valve with the system running! This can damage equipment and cause bodily injury.***

#### Two ways to charge the system

##### 10.3.2 Through the high side with A/C system off.

- Charge systems that heat the refrigerant will force the correct charge amount into the system. Once the full charge has been dispensed the service valve must be closed and the A/C system can be started.

##### 10.3.3 Through the low side with the system running.

- Charge systems with out heating capability will have to use A/C compressor to pull the required charge from the charge system. When charging through the suction side always use gas from the top of the charge system. Liquid refrigerant charged into the suction line can cause damage to compressor valves.

## **10.4 System Oil Balance**

### **10.4.1 Oil Flow**

- Compressor lubrication occurs as the oil which circulates with the refrigerant passes through the compressor crankcase during operation. The Sanden SD series compressor achieves optimal durability and cooling performance when oil circulates through the system at a ratio of 3.3% to 8% oil to refrigerant. Excess oil can act as an insulator limiting heat transfer in the evaporator and condenser, while too little oil can negatively effect durability.

### **10.4.2 In Laboratory Oil Amount Determination (OCR)**

- While the vehicle A/C is operating refrigerant samples are pulled from the liquid refrigerant line at several operating conditions. These samples are weighed then the refrigerant is evaporated from the sample leaving oil which is weighed again. Dividing the mass of the oil by the mass of the refrigerant plus oil will yield a ratio at the conditions the sample was taken. This measurement is referred to as the Oil Circulation Ratio or OCR.

### **10.4.2 Oil Checking Is Not Required Under Normal Conditions**

- The mobile refrigeration system is a closed loop system, hence it is not necessary to check or change oil in systems functioning normally and not in need of repair. The system isolates the oil and refrigerant from moisture and contaminants, while normal operating temperatures will be well below a point that will cause oil degradation.

### **10.4.4 When Oil Addition or Balancing is required**

- Compressor or component replacement
- Loss of refrigerant and oil mixture
- Adding oil to the system is required when refrigerant loss occurs due to leakage at any system component. Since oil is held in suspension with the refrigerant, oil will be lost with the escaping refrigerant gas. Oil will need to be inspected for contamination during repairs to determine if flushing is required

### **10.4.5 Oil Addition When Replacing System Components**

- A/C systems are designed to have a given oil charge so during component replacement the goal should be to maintain the initial factory oil charge. It is understood that system oil balance resulting from service activities is not an exact process, however using these guidelines should roughly maintain the OEM system oil charge.
- Operating conditions at the time of system shut down will determine where and how much oil settles in any given component in the A/C system. Therefore the exact amount of oil removed during refrigerant loss or component replacement can only be estimated in a shop environment. Sanden recommends adding SP-15 oil using these guidelines.

## System Oil Amount

- Oil circulates with the refrigerant during operation. During off periods oil will settle in all system components with more collecting in cool components like evaporators, accumulator and suction lines.

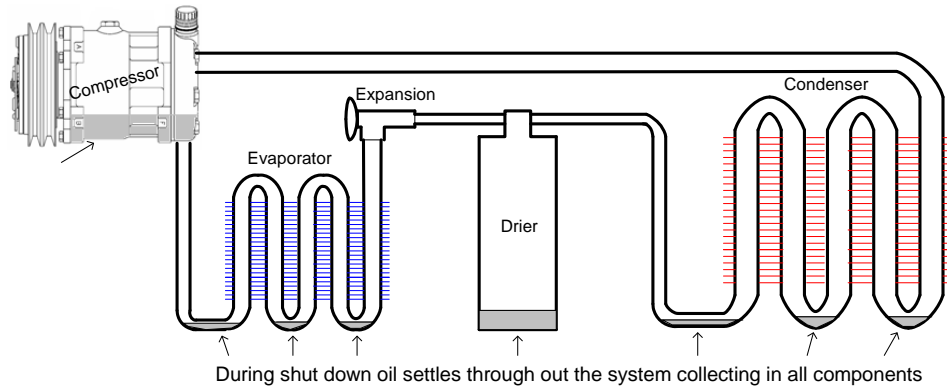

## Oil Replacement Amount During Service

- When replacing a system component the goal is to restore to the original factory oil amount. This amount can be found on the compressor label. Use the chart below as a guide for restoring oil quantities when replacing system components.

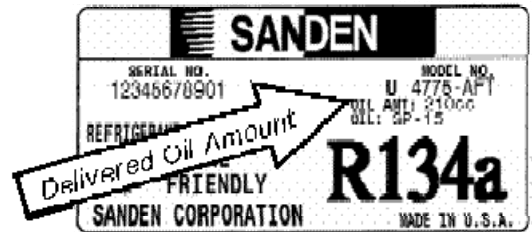

Component	Typical Oil Amount Large Truck		Typical Oil Amount Passenger Car	
	fl. oz.	cc	fl. oz.	cc
Major System Leak				
Suction Line To Rear Evaporator	3	88	1.5	44
Accumulator				
Condenser				
Evaporator	2	60	1	30
Receiver Drier				
Minor System Leak				
Suction Line To Front Evaporator	1	30	.5	15
Other Hoses or Hard Lines				
Compressor	Equal to amount drained from old compressor			

## Example

Large truck with no leak requires new compressor, suction hose and drier.

Drain oil from old compressor = 3 oz  
 Oil remaining in old compressor = .5 oz (see note below)  
 Oil lost from old suction hose = 1oz (from table)  
 Oil remaining in old drier = 1oz (from table)

**Amount to be added**

**5.5 oz**

Note: New compressors are delivered with full oil charge. It will be necessary to add or subtract from the delivered oil amount so the total in the compressor **equals the amount to be added.**

Example—If the new compressor contains 8 oz (240 cc) you must drain 2.5 oz so the total in the compressor is **5.5 oz.**

Note: When draining the old compressor roughly .5oz will remain in the compressor as film coating all internal surfaces.

# 11.0 Warranty

---

## 11.1 Warranty Process

- Sanden International provides limited warranty for all compressors manufactured. Customers wanting to return compressors for warranty consideration must contact the original equipment manufacturer or retail sales outlet from which the compressor was purchased.

## 11.2 Warranty Duration

- Sanden International warranty duration will vary based on a negotiated agreement between each individual OEM or retail distributor. Please consult the OEM or Retail point from which your compressor was purchased for duration specifics.

# 12.0 Common Causes of Compressor Failure

---

## 12.1 Compressor Overheated

- Overheating is most often caused by loss of refrigerant charge. Cool suction side refrigerant returning from the evaporator provides cooling for the compressor. Once the refrigerant charge is lost there is no refrigerant entering the compressor, hence no compressor cooling. Blockages in the system will also prevent cool refrigerant flow to the compressor.



Normal center ball and gear set



Overheated center ball and gear set

## 12.2 Compressor Contaminated

There are several types of contamination the most common are:

- Foreign material like metal chips, dirt and desiccant. Resulting in broken internal compressor components eventually locking up the compressor
- Moisture from improper evacuation or hose permeation. Moisture will corrode internal parts resulting in failure. Moisture will create higher system pressures or freeze in the expansion device and blocking refrigerant flow.
- A/C system flush

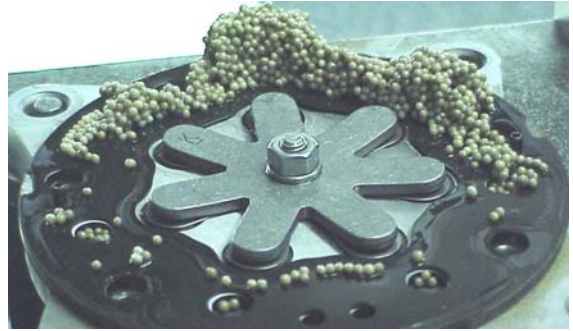

## 12.3 Clutch Slippage

- The compressor clutch is simply two friction surfaces forced together, like a set of brakes. Each time the clutch is engaged some amount heat is generated. If the engagements occur rapidly or the system voltage is too low, excessive heat created will cause failure of bearing seals and or melting of the field coil epoxy .



## 12.4 Handling or Impact Damage

- Striking, dropping or over torque will result in these types of damage:



# 13.0 Tools

## 13.1 Special Service Tools

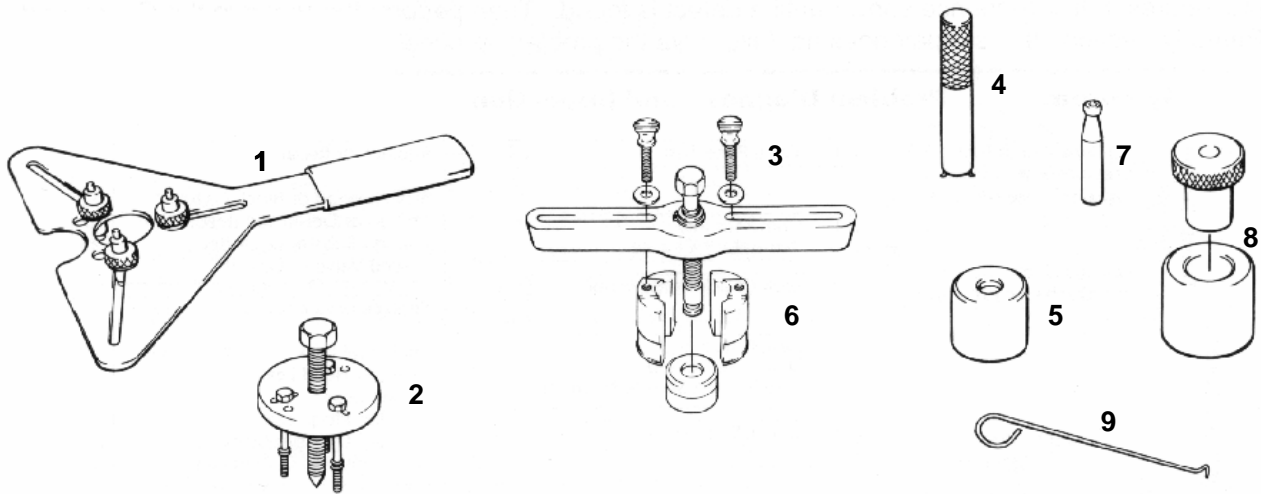

1. Armature Plate Spanner	4. Lip Seal / SD7 Seal Plate Tool	7. Shaft Seal Protective Sleeve
2. Armature Plate Puller	5. Armature Driver	8. Rotor Installation Driver
3. Rotor Puller Set	6. Rotor Puller Jaws	9. O-Ring Hook

## 13.2 Standard Tools

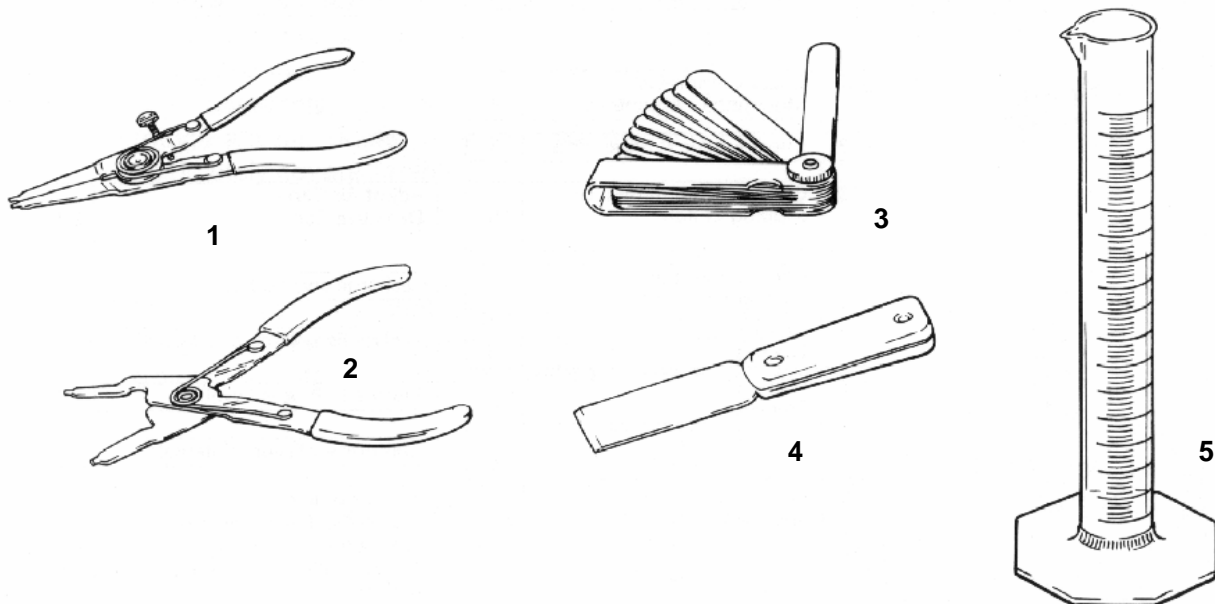

1. External Snap Ring Pliers	4. Gasket Scraper
2. Internal Snap Ring Pliers	5. Graduated Cylinder
3. Feeler Gauges	