

YANMAR

SERVICE MANUAL

INDUSTRIAL ENGINES

2TNV70

3TNV70

3TNV76

**California
Proposition 65 Warning**

Diesel engine exhaust and some of its constituents are known to the state of California to cause cancer, birth defects, and other reproductive harm.

**California
Proposition 65 Warning**

Battery posts, terminals, and related accessories contain lead and lead compounds, chemicals known to the state of California to cause cancer and reproductive harm.
Wash hands after handling.



TNV series

SERVICE MANUAL

2TNV70
3TNV70
3TNV76

P/N: 0BTNV-G00201

YANMAR[®]

**INDUSTRIAL
ENGINES**

This *Service Manual* has been developed for the exclusive use of service and repair professionals such as Yanmar authorized Distributors and Yanmar authorized Dealers. It is written with these professionals in mind and may not contain the necessary detail or safety statements that may be required for a non-professional to perform the service or repair properly and / or safely. Please contact an authorized Yanmar repair or service professional before working on your Yanmar product.

Disclaimers:

All information, illustrations and specifications in this manual are based on the latest information available at the time of publishing. The illustrations used in this manual are intended as representative reference views only. Moreover, because of our continuous product improvement policy, we may modify information, illustrations, and / or specifications to explain and / or exemplify a product, service, or maintenance improvement. We reserve the right to make any change at any time.

Yanmar and **YANMAR** are registered trademarks of Yanmar Co., Ltd. in Japan, the United States and / or other countries.

All Rights Reserved:

No part of this publication may be reproduced or used in any form by any means - graphic, electronic, or mechanical, including photocopying, recording, taping, or information storage and retrieval systems - without the written permission of Yanmar Co., Ltd.

© 2005 Yanmar Co. Ltd.

TABLE OF CONTENTS

	Page
Table of Contents	iii
Introduction	1-1
Yanmar Warranties	2-1
Safety	3-1
General Service Information	4-1
Periodic Maintenance	5-1
Engine	6-1
Fuel System	7-1
Cooling System	8-1
Lubrication System	9-1
Starter Motor	10-1
Alternator	11-1
Electric Wiring	12-1
Troubleshooting	13-1

This Page Intentionally Left Blank

Section 1

INTRODUCTION

This *Service Manual* describes the service procedures for the TNV series indirect injection engines. These engines are certified by the U.S. EPA, California ARB and/or the 97/68/EC Directive for industrial use.

Please use this manual for accurate, quick and safe servicing of the engine. Since the directions in this manual are for a typical engine, some specifications and components may be different from your engine. Refer to the documentation supplied by the optional equipment manufacturer for specific service instructions.

Yanmar products are continuously undergoing improvement. This *Service Manual* might not address possible field modifications to the equipment. Contact an authorized Yanmar industrial engine dealer or distributor for answers to any questions relating to field modifications.

This Page Intentionally Left Blank

Section 2

YANMAR WARRANTIES

	Page
Yanmar Limited Warranty.....	2-3
What is Covered by this Warranty?	2-3
How Long is the Warranty Period?	2-3
What the Engine Owner Must Do:	2-3
To Locate an Authorized Yanmar Industrial Engine Dealer or Distributor:	2-4
What Yanmar Will Do:	2-4
What is Not Covered by this Warranty?	2-4
Warranty Limitations:	2-5
Warranty Modifications:	2-5
Questions:	2-5
Retail Purchaser Registration.....	2-5
Emission System Warranty	2-6
Yanmar Co., Ltd. Limited Emission Control System Warranty - USA Only.....	2-6
Your Warranty Rights and Obligations:	2-6
Manufacturer's Warranty Period:.....	2-6
Warranty Coverage:	2-7
Warranted Parts:	2-7
Exclusions:	2-8
Owner's Warranty Responsibilities:.....	2-8

This Page Intentionally Left Blank

YANMAR LIMITED WARRANTY

What is Covered by this Warranty?

Yanmar warrants to the original retail purchaser that a new Yanmar TNV Series Industrial Engine will be free from defects in material and / or workmanship for the duration of the warranty period.

Note: Yanmar engines may be equipped with external components including, but not limited to: wiring harnesses, electrical devices, control panels, radiators, air filters, fuel filters, and / or exhaust systems that are supplied and / or installed by manufacturers other than Yanmar. For warranty information on such external components, please contact the machine or component manufacturer directly or see your authorized Yanmar dealer or distributor.

THIS WARRANTY IS PROVIDED IN LIEU OF ALL OTHER WARRANTIES, EXPRESSED OR IMPLIED. YANMAR SPECIFICALLY DISCLAIMS ANY IMPLIED WARRANTIES OF MERCHANTABILITY OR FITNESS FOR A PARTICULAR PURPOSE, except where such disclaimer is prohibited by law. IF SUCH DISCLAIMER IS PROHIBITED BY LAW, THEN IMPLIED WARRANTIES SHALL BE LIMITED IN DURATION TO THE LIFE OF THE EXPRESSED WARRANTY.

How Long is the Warranty Period?

The Yanmar standard limited warranty period runs for a period of **twenty-four (24) months or two-thousand (2000) engine operation hours**, whichever occurs first. An extended limited warranty of thirty-six (36) months or three thousand (3000) engine operating hours, whichever occurs first, is provided for these specific parts only: the cylinder block, cylinder head, crankshaft forging, connecting rods, flywheel, flywheel housing, camshaft, timing gear, and gear case. The Warranty Period for both the standard limited warranty and the extended limited warranty (by duration or operation hours) begins on the date of delivery to the original retail purchaser and is valid only until the applicable warranted duration has passed or the operation hours are exceeded, whichever comes first.

What the Engine Owner Must Do:

If you believe your Yanmar engine has experienced a failure due to a defect in material and / or workmanship, you must contact an authorized Yanmar industrial engine dealer or distributor within thirty (30) days of discovering the failure. You must provide proof of ownership of the engine, proof of the date of the engine purchase and delivery, and documentation of the engine operation hours. Acceptable forms of proof of delivery date include, but are not limited to: the original warranty registration or sales receipts or other documents maintained in the ordinary course of business by Yanmar dealers and / or distributors, indicating the date of delivery of the Yanmar product to the original retail purchaser. This information is necessary to establish whether the Yanmar product is still within the warranty period. Thus, Yanmar strongly recommends you register your engine as soon as possible after purchase in order to facilitate any future warranty matters.

You are responsible for the transportation of the engine to and from the repair location as designated by Yanmar.

*Yanmar Limited Warranty - Continued***To Locate an Authorized Yanmar Industrial Engine Dealer or Distributor:**

You can locate your nearest authorized Yanmar industrial engine dealer or distributor by visiting the Yanmar Corp., LTD. website at:

<http://www.yanmar.co.jp> (The Japanese language page will be displayed.) For English language “click” on “English Page.”)

- “Click” on “Network” in the website heading to view the “Yanmar Worldwide Network.”
- Choose and “Click” on the desired product group.
- “Click” on the Icon closest to your region.
- “Click” on the desired country or Associate company to locate your nearest authorized Yanmar industrial engine dealer or distributor.
- You may also contact Yanmar by clicking on “Inquiry” in the website heading and typing in your question or comment.

What Yanmar Will Do:

Yanmar warrants to the original retail purchaser of a new Yanmar engine that Yanmar will make such repairs and / or replacements at Yanmar’s option, of any parts(s) of the Yanmar product covered by this Warranty found to be defective in material and / or workmanship. Such repairs and / or replacements will be made at a location designated by Yanmar at no cost to the purchaser for parts or labor.

What is Not Covered by this Warranty?

This Warranty does not cover parts affected by or damaged by any reason other than defective materials or workmanship including, but not limited to, accident, misuse, abuse, “Acts of God”, neglect, improper installation, improper maintenance, improper storage, the use of unsuitable attachments or parts, the use of contaminated fuels, the use of fuels, oils, lubricants, or fluids other than those recommended in your Yanmar Operation Manual, unauthorized alterations or modifications, ordinary wear and tear, and rust or corrosion. This Warranty does not cover the cost of parts and / or labor required to perform normal / scheduled maintenance on your Yanmar engine. This Warranty does not cover consumable parts such as, but not limited to, filters, belts, hoses, fuel injector nozzles, lubricants and cleaning fluids. This warranty does not cover the cost of shipping the product to or from the warranty repair facility.

*Yanmar Limited Warranty - Continued***Warranty Limitations:**

The foregoing is Yanmar's only obligation to you and your exclusive remedy for breach of warranty. Failure to follow the requirements for submitting a claim under this Warranty may result in a waiver of all claims for damages and other relief. **In no event shall Yanmar or any authorized industrial engine dealer or distributor be liable for incidental, special or consequential damages.** Such consequential damages may include, but not be limited to, loss of revenue, loan payments, cost of rental of substitute equipment, insurance coverage, storage, lodging, transportation, fuel, mileage, and telephone costs. The limitations in this Warranty apply regardless of whether your claims are based on breach of contract, tort (including negligence and strict liability) or any other theory. Any action arising hereunder must be brought within one (1) year after the cause of action accrues or it shall be barred. Some states and countries do not allow certain limitations on warranties or for breach of warranties. **This Warranty gives you specific legal rights, and you may also have other rights which vary from state to state and country to country.** Limitations set forth in this paragraph shall not apply to the extent that they are prohibited by law.

Warranty Modifications:

Except as modified in writing and signed by the parties, this Warranty is and shall remain the complete and exclusive agreement between the parties with respect to warranties, superseding all prior agreements, written and oral, and all other communications between the parties relating to warranties. **No person or entity is authorized to give any other warranty or to assume any other obligation on behalf of Yanmar, either orally or in writing.**

Questions:

If you have any questions or concerns regarding this Warranty, please call or write to the nearest authorized Yanmar industrial engine dealer / distributor or other authorized facility.

Retail Purchaser Registration

It is very important for the original retail purchaser to register the Yanmar product. Registration enables Yanmar to provide the best support for your Yanmar product.

As soon as possible after the purchase of your engine, Yanmar highly recommends that you use the following website to register your purchase:

<http://www.yanmar.co.jp>

If it is not possible to access the web site, please contact the nearest Yanmar dealer or distributor.

EMISSION SYSTEM WARRANTY**YANMAR CO., LTD. LIMITED EMISSION CONTROL SYSTEM WARRANTY - USA ONLY****Your Warranty Rights and Obligations:****California**

The California Air Resources Board (CARB), the Environmental Protection Agency (EPA) and Yanmar Co., Ltd. hereafter referred to as Yanmar, are pleased to explain the **emission control system warranty** on your industrial compression-ignition engine. In California, model year 2000 or later off-road compression-ignition engines must be designed, built and equipped to meet the State's stringent anti-smog standards. In all states, 1998 and later non-road compression-ignition engines must be designed, built and equipped to meet the United States EPA emissions standards. Yanmar warrants the emission control system on your engine for the periods of time listed below provided there has been no abuse, neglect or improper maintenance of your engine.

Your emission control system may include parts such as the fuel injection system and the air induction system. Also included may be hoses, belts, connectors and other emission-related assemblies.

Where a warrantable condition exists, Yanmar will repair your non-road compression-ignition engine at no charge to you including diagnosis, parts and labor.

Manufacturer's Warranty Period:

The model year 1998 or later certified and labeled non-road compression-ignition engines are warranted for the periods listed below. If any emission-related part on your engine is found to be defective during the applicable warranty period, the part will be replaced by Yanmar.

Engine Type	Warranty Period by Number of Years or Hours of Operation
Constant speed engines rated at or above 50 hp SAE (37 kW)	The warranty period is five (5) years or 3,000 hours of use, whichever occurs first. In the absence of a device to measure the hours of use, the engine has a warranty period of five (5) years.
Constant speed engines rated under 50 hp SAE (37 kW) with rated speeds greater than or equal to 3,000 rpm	The warranty period is two (2) years or 1,500 hours of use, whichever occurs first. In the absence of a device to measure the hours of use, the engine has a warranty period of two (2) years.
Constant speed engines rated under 50 hp SAE (37 kW) and engines rated at or above 26 hp SAE (19 kW) with rated speeds less than 3,000 rpm	The warranty period is five (5) years or 3,000 hours of use, whichever occurs first. In the absence of a device to measure the hours of use, the engine has a warranty period of five (5) years.
Engines rated at or above 26 hp SAE (19 kW)	The warranty period is five (5) years or 3,000 hours of use, whichever occurs first. In the absence of a device to measure the hours of use, the engine has a warranty period of five (5) years.
Engines rated under 26 hp SAE (19 kW)	The warranty period is two (2) years or 1,500 hours of use, whichever occurs first. In the absence of a device to measure the hours of use, the engine has a warranty period of two (2) years.

Limited Emission Control System Warranty - USA Only - Continued**Warranty Coverage:**

This warranty is transferable to each subsequent purchaser for the duration of the warranty period. Repair or replacement of any warranted part will be performed at an authorized Yanmar industrial engine dealer or distributor.

Warranted parts not scheduled for replacement as required maintenance in the Operation Manual shall be warranted for the warranty period. Warranted parts scheduled for replacement as required maintenance in the operation manual are warranted for the period of time prior to the first scheduled replacement. Any part repaired or replaced under warranty shall be warranted for the remaining warranty period.

During the warranty period, Yanmar is liable for damages to other engine components caused by the failure of any warranted part during the warranty period.

Any replacement part which is functionally identical to the original equipment part in all respects may be used in the maintenance or repair of your engine, and shall not reduce Yanmar's warranty obligations. Add-on or modified parts that are not exempted may not be used. The use of any non-exempted add-on or modified parts shall be grounds for disallowing a warranty.

Warranted Parts:

This warranty covers engine components that are a part of the emission control system of the engine as delivered by Yanmar to the original retail purchaser. Such components may include the following:

- Fuel Injection System
- Cold Start Enrichment System
- Intake Manifold
- Turbocharger Systems
- Exhaust Manifold
- Positive Crankcase Ventilation System
- Hoses, belts, connectors and assemblies associated with emission control systems

Since emissions-related parts may vary slightly between models, certain models may not contain all of these parts and other models may contain the functional equivalents.

Limited Emission Control System Warranty - USA Only - Continued**Exclusions:**

Failures other than those arising from defects in material and / or workmanship are not covered by this warranty. The warranty does not extend to the following: malfunctions caused by abuse, misuse, improper adjustment, modification, alteration, tampering, disconnection, improper or inadequate maintenance or use of non-recommended fuels and lubricating oils; accident-caused damage, and replacement of expendable items made in connection with scheduled maintenance. Yanmar disclaims any responsibility for incidental or consequential damages such as loss of time, inconvenience, loss of use of equipment / engine or commercial loss.

Owner's Warranty Responsibilities:

As the engine owner, you are responsible for the performance of the required maintenance listed in your owner's manual. Yanmar recommends that you retain all documentation, including receipts, covering maintenance on your non-road compression-ignition engine, but Yanmar cannot deny warranty solely for the lack of receipts, or for your failure to ensure the performance of all scheduled maintenance.

Yanmar may deny your warranty coverage of your non-road compression-ignition engine if a part has failed due to abuse, neglect, improper maintenance or unapproved modifications.

Your engine is designed to operate on diesel fuel only. Use of any other fuel may result in your engine no longer operating in compliance with applicable emissions requirements.

You are responsible for initiating the warranty process. You must present your engine to a Yanmar dealer as soon as a problem exists. The warranty repairs should be completed by the dealer as expeditiously as possible. If you have any questions regarding your warranty rights and responsibilities, or would like information on the nearest Yanmar dealer or authorized service center, you should contact Yanmar America Corporation at 1-800-872-2867.

Section 3

SAFETY

	Page
Safety Statements	3-3
Safety Precautions	3-4

This Page Intentionally Left Blank

SAFETY STATEMENTS

Yanmar is concerned for your safety and your machine's condition. Safety statements are one of the primary ways to call your attention to the potential hazards associated with Yanmar TNV engine operation. Follow the precautions listed throughout the manual before operation, during operation and during periodic maintenance procedures for your safety, the safety of others and to protect the performance of your engine. Keep the labels from becoming dirty or torn and replace them if they are lost or damaged. Also, if you need to replace a part that has a label attached to it, make sure you order the new part and label at the same time.



This safety alert symbol appears with most safety statements. It means attention, become alert, your safety is involved! Please read and abide by the message that follows the safety alert symbol.

⚠ DANGER
<p>Danger (the word "DANGER" is in white letters with a red rectangle behind it) - indicates an imminently hazardous situation which, if not avoided, will result in death or serious injury. Danger is limited to the most extreme situations.</p> <p style="text-align: right;">0000001en</p>

⚠ WARNING
<p>Warning (the word "WARNING" is in black letters with an orange rectangle behind it) – indicates a potentially hazardous situation which, if not avoided, could result in death or serious injury.</p> <p style="text-align: right;">0000001en</p>

⚠ CAUTION
<p>Caution (the word "CAUTION" is in black letters with a yellow rectangle behind it) – indicates a potentially hazardous situation which, if not avoided, may result in minor or moderate injury.</p> <p style="text-align: right;">0000001en</p>

CAUTION
<p>Caution without the safety alert symbol indicates a potentially hazardous situation that can cause damage to the machine, personal property and / or the environment or cause the machine to operate improperly.</p> <p style="text-align: right;">0000001en</p>

SAFETY PRECAUTIONS

⚠ DANGER



SCALD HAZARD!

- NEVER remove the radiator cap if the engine is hot. Steam and hot engine coolant will spurt out and seriously burn you. Allow the engine to cool down before you attempt to remove the radiator cap.
- Tighten the radiator cap securely after you check the radiator. Steam can spurt out during engine operation if the cap is loose.
- ALWAYS check the level of the engine coolant by observing the reserve tank.
- Failure to comply will result in death or serious injury.

000002en

⚠ DANGER



EXPLOSION HAZARD!

- Keep the area around the battery well-ventilated. While the engine is running or the battery is charging, hydrogen gas is produced which can be easily ignited.
- Keep sparks, open flame and any other form of ignition away while the engine is running or battery is charging.
- Failure to comply will result in death or serious injury.

000003en

⚠ DANGER



FIRE AND EXPLOSION HAZARD!

- Diesel fuel is flammable and explosive under certain conditions.
- When you remove any fuel system component to perform maintenance (such as changing the fuel filter) place an approved container under the opening to catch the fuel.
- NEVER use a shop rag to catch the fuel. Vapors from the rag are flammable and explosive.
- Wipe up any spills immediately.
- Wear eye protection. The fuel system is under pressure and fuel could spray out when you remove any fuel system component.
- Failure to comply will result in death or serious injury.

000009en

⚠ DANGER



FIRE AND EXPLOSION HAZARD!

- Only use the key switch to start the engine.
- NEVER jump-start the engine. Sparks caused by shorting the battery to the starter terminals may cause a fire or explosion.
- Failure to comply will result in death or serious injury.



000004en

 DANGER

<p>FIRE AND EXPLOSION HAZARD!</p> <ul style="list-style-type: none"> • Diesel fuel is flammable and explosive under certain conditions. • NEVER remove the fuel cap with the engine running. • Failure to comply will result in death or serious injury. <p style="text-align: right;">0000011en</p>

 DANGER

<p>FIRE AND EXPLOSION HAZARD!</p> <ul style="list-style-type: none"> • Diesel fuel is flammable and explosive under certain conditions. • NEVER use diesel fuel as a cleaning agent. • Failure to comply will result in death or serious injury. <p style="text-align: right;">0000012en</p>

 DANGER

<p>FIRE AND EXPLOSION HAZARD!</p> <ul style="list-style-type: none"> • Diesel fuel is flammable and explosive under certain conditions. • Only fill the fuel tank with diesel fuel. Filling the fuel tank with gasoline may result in a fire and will damage the engine. • NEVER refuel with the engine running. • Wipe up all spills immediately. • Keep sparks, open flames or any other form of ignition (match, cigarette, static electric source) well away when refueling. • NEVER overfill the fuel tank. • Fill the fuel tank. Store any containers containing fuel in a well-ventilated area, away from any combustibles or sources of ignition. • Failure to comply will result in death or serious injury. <p style="text-align: right;">0000005en</p>

⚠ DANGER**FIRE AND EXPLOSION HAZARD!**

- Diesel fuel is flammable and explosive under certain conditions.
- If the unit has an electric fuel pump, when you prime the fuel system, turn the key switch to the ON position for 10 to 15 seconds to allow the electric fuel pump to prime the system.
- If the unit has a mechanical fuel pump, when you prime the fuel system, operate the fuel priming lever of the mechanical fuel pump several times until the fuel filter cup is filled with fuel.
- Failure to comply will result in death or serious injury.

0000010en

⚠ DANGER**FIRE AND EXPLOSION HAZARD!**

- Diesel fuel is flammable and explosive under certain conditions.
- Be sure to place the diesel fuel container on the ground when transferring the diesel fuel from the pump to the container. Hold the hose nozzle firmly against the side of the container while filling it. This prevents static electricity buildup which could cause sparks and ignite fuel vapors.
- NEVER place diesel fuel or other flammable material such as oil, hay or dried grass close to the engine during engine operation or shortly after shutdown.
- Failure to comply will result in death or serious injury.

0000014en

⚠ DANGER



CRUSH HAZARD!

- When you need to transport an engine for repair, have a helper assist you to attach it to a hoist and load it on a truck.
- NEVER stand under a hoisted engine. If the hoist mechanism fails, the engine will fall on you, causing death or serious injury.
- Failure to comply will result in death or serious injury.

000008en

⚠ DANGER



EXPLOSION HAZARD!

- NEVER check the remaining battery charge by shorting out the terminals. This will result in a spark and may cause an explosion or fire. Use a hydrometer to check the remaining battery charge.
- If the electrolyte is frozen, slowly warm the battery before you recharge it.
- Failure to comply will result in death or serious injury.

000007en

⚠ WARNING



SEVER HAZARD!

- Keep hands and other body parts away from moving / rotating parts such as the cooling fan, flywheel or PTO shaft.
- Wear tight-fitting clothing and keep your hair short or tie it back while the engine is running.
- Remove all jewelry before you operate or service the machine.
- NEVER start the engine in gear. Sudden movement of the engine and / or machine could cause death or serious personal injury.
- NEVER operate the engine without the guards in place.
- Before you start the engine make sure that all bystanders are clear of the area.
- Keep children and pets away while the engine is operating.
- Check before starting the engine that any tools or shop rags used during maintenance have been removed from the area.
- Failure to comply could result in death or serious injury.

000002en

⚠ WARNING**EXHAUST HAZARD!**

- NEVER operate the engine in an enclosed area such as a garage, tunnel, underground room, manhole or ship's hold without proper ventilation.
- NEVER block windows, vents, or other means of ventilation if the engine is operating in an enclosed area. All internal combustion engines create carbon monoxide gas during operation. Accumulation of this gas within an enclosure could cause illness or even death.
- Make sure that all connections are tightened to specifications after repair is made to the exhaust system.
- Failure to comply could result in death or serious injury.

000003en

⚠ WARNING**ALCOHOL AND DRUG HAZARD!**

- NEVER operate the engine while you are under the influence of alcohol or drugs.
- NEVER operate the engine when you are feeling ill.
- Failure to comply could result in death or serious injury.

000004en

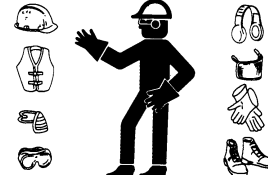
⚠ WARNING**EXPOSURE HAZARD!**

- Wear personal protective equipment such as gloves, work shoes, eye and hearing protection as required by the task at hand.
- NEVER wear jewelry, unbuttoned cuffs, ties or loose-fitting clothing when you are working near moving / rotating parts such as the cooling fan, flywheel or PTO shaft.
- ALWAYS tie back long hair when you are working near moving / rotating parts such as a cooling fan, flywheel, or PTO shaft.
- NEVER operate the engine while wearing a headset to listen to music or radio because it will be difficult to hear the alert signals.
- Failure to comply could result in death or serious injury.

000005en

⚠ WARNING



BURN HAZARD!

- If you must drain the engine oil while it is still hot, stay clear of the hot engine oil to avoid being burned.
- **ALWAYS** wear eye protection.
- Failure to comply could result in death or serious injury.

0000011en

⚠ WARNING



BURN HAZARD!

- Batteries contain sulfuric acid. **NEVER** allow battery fluid to come in contact with clothing, skin or eyes. Severe burns could result. **ALWAYS** wear safety goggles and protective clothing when servicing the battery. If battery fluid contacts the eyes and / or skin, immediately flush the affected area with a large amount of clean water and obtain prompt medical treatment.
- Failure to comply could result in death or serious injury.

0000007en

⚠ WARNING



HIGH-PRESSURE HAZARD!

- Avoid skin contact with the high-pressure diesel fuel spray caused by a fuel system leak such as a broken fuel injection line. High-pressure fuel can penetrate your skin and result in serious injury. If you are exposed to high-pressure fuel spray, obtain prompt medical treatment.
- **NEVER** check for a fuel leak with your hands. **ALWAYS** use a piece of wood or cardboard. Have your authorized Yanmar industrial engine dealer or distributor repair the damage.
- Failure to comply could result in death or serious injury.

0000008en

⚠ WARNING



SHOCK HAZARD!

- Turn off the battery switch (if equipped) or disconnect the negative battery cable before servicing the electrical system.
- Check the electrical harnesses for cracks, abrasions, and damaged or corroded connectors. **ALWAYS** keep the connectors and terminals clean.
- Failure to comply could result in death or serious injury.

0000009en

⚠ WARNING**ENTANGLEMENT HAZARD!**

- Stop the engine before you begin to service it.
- NEVER leave the key in the key switch when you are servicing the engine. Someone may accidentally start the engine and not realize you are servicing it. This could result in a serious injury.
- If you must service the engine while it is operating, remove all jewelry, tie back long hair, and keep your hands, other body parts and clothing away from moving / rotating parts.
- Failure to comply could result in death or serious injury.

0000010en

⚠ WARNING**BURN HAZARD!**

- Wait until the engine cools before you drain the engine coolant. Hot engine coolant may splash and burn you.
- Failure to comply could result in death or serious injury.

0000016en

⚠ WARNING

To prevent possible eye injury, always wear **SAFETY GLASSES** while servicing the engine.

0000013en

⚠ WARNING**BURN HAZARD!**

- Keep your hands and other body parts away from hot engine surfaces such as the muffler, exhaust pipe, turbocharger (if equipped) and engine block during operation and shortly after you shut the engine down. These surfaces are extremely hot while the engine is operating and could seriously burn you.
- Failure to comply could result in death or serious injury.

0000015en

⚠ WARNING

FUME / BURN HAZARD!

- Always read and follow safety related precautions found on containers of hazardous substances like parts cleaners, primers, sealants and sealant removers.
- Failure to comply could result in death or serious injury.

0000014en

⚠ CAUTION

FLYING OBJECT HAZARD!

- **ALWAYS** wear eye protection when servicing the engine and when using compressed air or high-pressure water. Dust, flying debris, compressed air, pressurized water or steam may injure your eyes.
- Failure to comply may result in minor or moderate injury.

0000003en

⚠ CAUTION

COOLANT HAZARD!

- Wear eye protection and rubber gloves when you handle long life or extended life engine coolant. If contact with the eyes or skin should occur, flush eyes and wash immediately with clean water.
- Failure to comply may result in minor or moderate injury.

0000005en

⚠ CAUTION

Be sure to secure the engine solidly to prevent injury or damage to parts due to the engine falling during work on the engine.

0000009en

⚠ CAUTION

PINCH HAZARD!

Carefully rotate the alternator toward the cylinder block while loosening the V-belt. Failure to comply may result in minor or moderate injury.

0000014en

⚠ CAUTION

If any oil pump component clearance exceeds its limit, the oil pump must be replaced as an assembly.

0000015en

CAUTION

- Only use diesel fuels recommended by Yanmar for the best engine performance, to prevent engine damage and to comply with EPA / ARB warranty requirements.
- Only use clean diesel fuel.
- NEVER remove the primary strainer (if equipped) from the fuel tank filler port. If removed, dirt and debris could get into the fuel system causing it to clog.

0000004en

CAUTION

If any problem is noted during the visual check, the necessary corrective action should be taken before you operate the engine.

0000021en

CAUTION

NEVER hold the key in the START position for longer than 15 seconds or the starter motor will overheat.

0000007en

CAUTION

Make sure the engine is installed on a level surface. If a continuously running engine is installed at an angle greater than (IDI = 25°, DI = 30°) in any direction or if an engine runs for short periods of time (less than three minutes) at an angle greater than (IDI = 30°, DI = 35°) in any direction, engine oil may enter the combustion chamber causing excessive engine speed and white exhaust smoke. This may cause serious engine damage.

0000010enTNV

CAUTION

Protect the air cleaner, turbocharger (if equipped) and electric components from damage when you use steam or high-pressure water to clean the engine.

0000014en

CAUTION

Observe the following environmental operating conditions to maintain engine performance and avoid premature engine wear:

- Avoid operating in extremely dusty conditions.
- Avoid operating in the presence of chemical gases or fumes.
- Avoid operating in a corrosive atmosphere such as salt water spray.
- NEVER install the engine in a floodplain unless proper precautions are taken to avoid being subject to a flood.
- NEVER expose the engine to the rain.

0000003en

CAUTION

Do not loosen or remove the four bolts retaining the fuel injection pump drive gear to the fuel injection pump hub. Do not disassemble the fuel injection pump drive gear from the hub. Correct fuel injection timing will be very difficult or impossible to achieve.

0000031en

CAUTION

If the oil pump must be replaced, replace it as an assembly only. Do not replace individual components.

0000030en

CAUTION

Observe the following environmental operating conditions to maintain engine performance and avoid premature engine wear:

- The standard range of ambient temperatures for the normal operation of Yanmar engines is from +5°F (-15°C) to +113°F (+45°C).
- If the ambient temperature exceeds +113°F (+45°C) the engine may overheat and cause the engine oil to break down.
- If the ambient temperature is below +5°F (-15°C) the engine will be hard to start and the engine oil may not flow easily.
- Contact your authorized Yanmar industrial engine dealer or distributor if the engine will be operated outside of this standard temperature range.

0000065en

CAUTION

If any indicator illuminates during engine operation, stop the engine immediately. Determine the cause and repair the problem before you continue to operate the engine.

0000029en

CAUTION

- Only use the engine oil specified. Other engine oils may affect warranty coverage, cause internal engine components to seize and / or shorten engine life.
- Prevent dirt and debris from contaminating the engine oil. Carefully clean the oil cap / dipstick and the surrounding area before you remove the cap.
- NEVER mix different types of engine oil. This may adversely affect the lubricating properties of the engine oil.
- NEVER overfill. Overfilling may result in white exhaust smoke, engine overspeed or internal damage.

0000005en

CAUTION

- Only use the engine coolant specified. Other engine coolants may affect warranty coverage, cause an internal buildup of rust and scale and / or shorten engine life.
- Prevent dirt and debris from contaminating the engine coolant. Carefully clean the radiator cap and the surrounding area before you remove the cap.
- NEVER mix different types of engine coolants. This may adversely affect the properties of the engine coolant.

0000006en

CAUTION

- **NEVER** overfill the engine with engine oil.
- **ALWAYS** keep the oil level between the upper and lower lines on the oil cap / dipstick.

0000015en

CAUTION

For maximum engine life, Yanmar recommends that when shutting the engine down, you allow the engine to idle, without load, for five minutes. This will allow the engine components that operate at high temperatures, such as the turbocharger (if equipped) and exhaust system, to cool slightly before the engine itself is shut down.

0000008en

CAUTION

NEVER use an engine starting aid such as ether. Engine damage will result.

0000009en

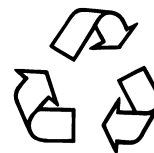
CAUTION

- **ALWAYS** be environmentally responsible.
- Follow the guidelines of the EPA or other governmental agencies for the proper disposal of hazardous materials such as engine oil, diesel fuel and engine coolant. Consult the local authorities or reclamation facility.
- **NEVER** dispose of hazardous materials irresponsibly by dumping them into a sewer, on the ground, or into ground water or waterways.
- Failure to follow these procedures may seriously harm the environment.

0000013en

CAUTION**New Engine Break-in:**

- On the initial engine start-up, allow the engine to idle for approximately 15 minutes while you check for proper engine oil pressure, diesel fuel leaks, engine oil leaks, coolant leaks, and for proper operation of the indicators and / or gauges.
- During the first hour of operation, vary the engine speed and the load on the engine. Short periods of maximum engine speed and load are desirable. Avoid prolonged operation at minimum or maximum engine speeds and loads for the next four to five hours.
- During the break-in period, carefully observe the engine oil pressure and engine temperature.
- During the break-in period, check the engine oil and coolant levels frequently.

0000011en

CAUTION

NEVER engage the starter motor while the engine is running. This may damage the starter motor pinion and / or ring gear.

0000012en

CAUTION

- **NEVER** attempt to modify the engine's design or safety features such as defeating the engine speed limit control or the fuel injection quantity control.
- Failure to comply may impair the engine's safety and performance characteristics and shorten the engine's life. Any alterations to this engine may affect the warranty coverage of your engine. *Yanmar Limited Warranty on page 2-3.*

0000044TNVIDISM

CAUTION

NEVER use high-pressure water or compressed air at greater than 28 psi (193 kPa; 19 686 mmAq) or a wire brush to clean the radiator fins. Radiator fins damage easily.

0000016en

CAUTION

NEVER attempt to adjust the low or high idle speed limit screw. This may impair the safety and performance of the machine and shorten its life. If the idle speed limit screws require adjustment, see your authorized Yanmar industrial engine dealer or distributor.

0000017en

CAUTION

The starter motor can be damaged if operated continuously longer than 10 seconds while performing the no-load test.

0000034en

CAUTION

The tightening torque in the *Standard Torque Chart in General Service Information* should be applied only to the bolts with a “7” head. (JIS strength classification: 7T)

- Apply 60% torque to bolts that are not listed.
- Apply 80% torque when tightened to aluminum alloy.



0000023enTNVIDISM

CAUTION

Establish a periodic maintenance plan according to the engine application and make sure you perform the required periodic maintenance at intervals indicated. Failure to follow these guidelines will impair the engine's safety and performance characteristics, shorten the engine's life and may affect the warranty coverage on your engine. *See Yanmar Warranties section.*

Consult your authorized Yanmar dealer or distributor for assistance when checking items marked with a ●.

0000024enTNVIDISM

CAUTION

If the fuel filter / water separator is positioned higher than the fuel level in the fuel tank, water may not drip out when the fuel filter / water separator drain cock is opened. If this happens, turn the air vent screw on the top of the fuel filter / water separator 2-3 turns counterclockwise.

Be sure to tighten the air vent screw after the water has drained out.

0000025en

CAUTION

- When the engine is operated in dusty conditions, clean the air cleaner element more frequently.
- NEVER operate the engine with the air cleaner element(s) removed. This may allow foreign material to enter the engine and damage it.

0000026en

CAUTION

The maximum air intake restriction, in terms of differential pressure measurement, must not exceed 0.90 psi (6.23 kPa; 635 mmAq). Clean or replace the air cleaner element if the air intake restriction exceeds the above mentioned value.

0000046en

CAUTION

Do not short-circuit the charging system between alternator terminals IG and L. Damage to the alternator will result.

0000035en

CAUTION

Do not connect a load between alternator terminals L and E. Damage to the alternator will result.

0000036en

CAUTION

Do not remove the positive (+) battery cable from alternator terminal B while the engine is operating. Damage to the alternator will result.

0000037en

CAUTION

Do not turn the battery switch OFF while the engine is operating. Damage to the alternator will result.

0000038en

CAUTION

Do not operate the engine if the alternator is producing unusual sounds. Damage to the alternator will result.

0000039en

CAUTION

If the engine coolant pump must be replaced, replace the engine coolant pump as an assembly only. Do not attempt to repair the engine coolant pump or replace individual components.

0000041en

CAUTION

Use a new special O-ring between the engine coolant pump and the joint. Be sure to use the special O-ring for each engine model. Although the O-ring dimensions are the same as a commercially available O-ring, the material is different.

0000042en

CAUTION

Remove or install the high-pressure fuel injection lines as an assembly whenever possible. Disassembling the high-pressure fuel injection lines from the retainers or bending any of the fuel lines will make it difficult to reinstall the fuel lines.

0000047en

CAUTION

After marking the position of the pump drive gear, do not rotate the engine crankshaft. Rotating the crankshaft will cause the fuel injection pump to become misaligned.

0000048en

CAUTION

Do not use a high-pressure wash directly on the alternator. Water will damage the alternator and result in inadequate charging.

0000049en

CAUTION

Do not reverse the positive (+) and negative (-) ends of the battery cable. The alternator diode and stator coil will be damaged.

0000050en

CAUTION

When the battery indicator goes out, it should not come on again. The battery indicator only comes on during operation if the alternator fails. However, if an LED is used in the battery indicator, the LED will shine faintly during normal operation.

0000051en

CAUTION

Using a non-specified V-belt will cause inadequate charging and shorten the belt life. Use the specified belt.

0000052en

CAUTION

Agricultural or other chemicals, especially those with a high sulfur content, can adhere to the IC regulator. This will corrode the conductor and result in battery over-charging (boiling) and charging malfunctions. Consult Yanmar before using the equipment in such an environment or the warranty is voided.

0000053en

CAUTION

Make sure that the combined total resistance of the battery cable in both directions between the starter motor and the battery is within the value indicated on the wiring diagram. The starter motor will malfunction or break down if the resistance is higher than the specified value.

0000054en

CAUTION

The starter motor is water-proofed according to JIS D 0203, R2 which protects the motor from rain or general cleaning. Do not use high-pressure wash or submerge the starter motor in water.

0000055en

CAUTION

Use a specialized battery charger to recharge a battery with a voltage of 8 volts or less. Booster starting a battery with a voltage of 8 volts or less will generate an abnormally high voltage and destroy electrical equipment.

0000056en

CAUTION

Make sure that the combined total resistance of the battery cable in both directions between the starter motor and the battery is within the value indicated in the *Battery Cable Resistance chart* in the *Electric Wiring Section* of this manual. The starter motor will malfunction and fail if the resistance is higher than the specified value.

0000057en

CAUTION

Removing the battery cables or the battery while the engine is operating may cause damage to the current limiter depending on the electrical equipment being used. This situation could cause loss of control of output voltage. The continuous high voltage of 23-24 volts (for 5000 rpm dynamo) will damage the current limiter and other electrical equipment.

0000058en

CAUTION

Reversing the battery cable connections at the battery or on the engine will destroy the SCR diode in the current limiter. This will cause the charging system to malfunction and may cause damage to the electrical harnesses.

0000059en

CAUTION

It is important to perform daily checks. Periodic maintenance prevents unexpected downtime, reduces the number of accidents due to poor machine performance and helps extend the life of the engine.

0000060en

CAUTION

- NEVER attempt to modify the engine's design or safety features such as defeating the engine speed limit control or the diesel fuel injection quantity control.
- Modifications may impair the engine's safety and performance characteristics and shorten the engine's life. Any alterations to this engine may void its warranty. Be sure to use Yanmar genuine replacement parts.

0000079en

CAUTION

Do not allow the honing tool to operate in one position for any length of time. Damage to the cylinder wall will occur. Keep the tool in constant up-and-down motion.

0000090en

CAUTION

Any part which is found defective as a result of inspection or any part whose measured value does not satisfy the standard or limit must be replaced.

0000119en

CAUTION

Identify all parts and their location using an appropriate method. It is important that all parts are returned to the same position during the reassembly process.

0000080en

CAUTION

Do not rotate the crankshaft with the injection pump removed.

0000083en

CAUTION

Keep the piston pin parts, piston assemblies, and connecting rod assemblies together to be returned to the same position during the reassembly process. Label the parts using an appropriate method.

0000088en

CAUTION

Any part determined to not meet the service standard or limit before the next service, as determined from the state of current rate of wear, should be replaced even though the part currently meets the service standard limit.

0000120en

CAUTION

Never use a steel wire brush to clean fuel injectors. Damage to the nozzle and other components is likely to result.

0000172en

CAUTION

- **NEVER** remove or attempt to remove the tamper-proof devices from the full-load fuel adjusting screw or the high-speed throttle limit screw on the fuel injection pump and governor assembly. These adjustments have been made at the factory to meet all applicable emissions regulations and then sealed.
- **NEVER** attempt to make any adjustments to these sealed adjustment screws. If adjustments are required, they can be made only by a qualified fuel injection shop that will ensure the injection pump continues to meet all applicable emissions regulations and then replace the tamper-proof seals.
- Tampering with or removing these devices may void the “Yanmar Limited Warranty.”

0000146en

CAUTION

The fuel return line is a one-piece assembly. Use care not to bend or twist the fuel return line.

0000171en

Section 4

GENERAL SERVICE INFORMATION

	Page
Component Identification.....	4-3
Location of Labels	4-4
EPA / ARB Emission Control Regulations - USA Only.....	4-4
Emission Control Labels.....	4-4
EPA / ARB Labels	4-5
The 97/68/EC Directive Certified Engines.....	4-5
Engine Family.....	4-5
Function of Major Engine Components	4-6
Function of Cooling System Components	4-8
Diesel Fuel	4-9
Diesel Fuel Specifications	4-9
Filling the Fuel Tank	4-10
Priming the Fuel System	4-12
Engine Oil.....	4-13
Engine Oil Specifications	4-13
Service Categories	4-13
Engine Oil Viscosity.....	4-14
Checking Engine Oil.....	4-14
Adding Engine Oil.....	4-14
Engine Oil Capacity (Typical)	4-15
Engine Coolant.....	4-15
Engine Coolant Specifications.....	4-16
Filling Radiator with Engine Coolant.....	4-16
Engine Coolant Capacity (Typical)	4-17
Specifications	4-18
Description of Model Number	4-18
Engine Speed Specifications.....	4-18
Engine General Specifications	4-19

GENERAL SERVICE INFORMATION

Principal Engine Specifications	4-20
2TNV70	4-20
3TNV70	4-21
3TNV76	4-22
Engine Service Information	4-23
Tightening Torques for Standard Bolts and Nuts	4-24
Abbreviations and Symbols	4-26
Abbreviations	4-26
Symbols	4-26
Unit Conversions	4-27
Unit Prefixes	4-27
Units of Length	4-27
Units of Volume	4-27
Units of Mass	4-27
Units of Force	4-27
Units of Torque	4-27
Units of Pressure	4-27
Units of Power	4-27
Units of Temperature	4-27

COMPONENT IDENTIFICATION

Figure 4-1 shows where major engine components are located.

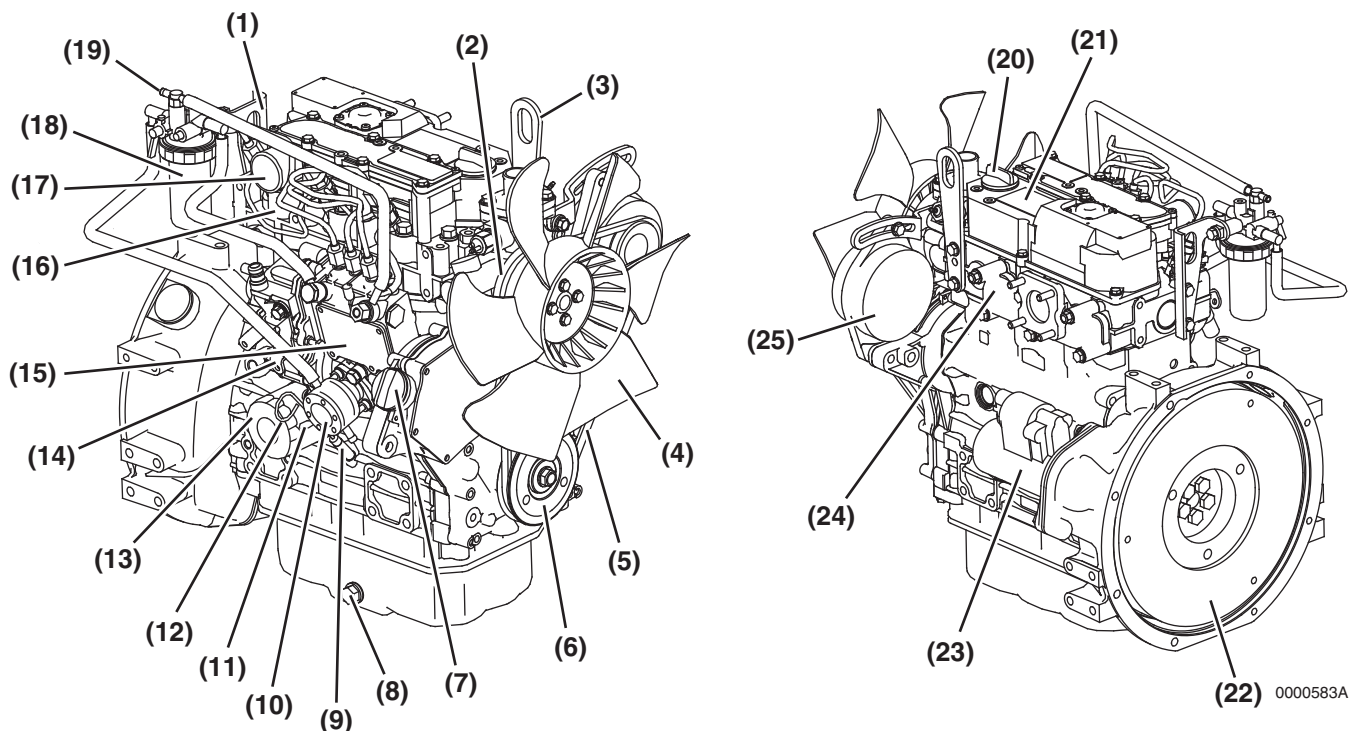

Figure 4-1

- | | |
|--|---|
| 1 – Lifting Eye (Flywheel End) | 14 – Governor Lever |
| 2 – Engine Coolant Pump | 15 – Fuel Injection Pump |
| 3 – Lifting Eye (Engine Cooling Fan End) | 16 – Intake Manifold |
| 4 – Engine Cooling Fan | 17 – Air Intake Port (From Air Cleaner) |
| 5 – V-Belt | 18 – Fuel Filter |
| 6 – Crankshaft V-Pulley | 19 – Fuel Return To Fuel Tank |
| 7 – Side Filler Port (Engine Oil) | 20 – Top Filler Port (Engine Oil) |
| 8 – Drain Plug (Engine Oil)* | 21 – Rocker Arm Cover |
| 9 – Fuel Inlet | 22 – Flywheel |
| 10 – Mechanical Fuel Pump (If Equipped) | 23 – Starter Motor |
| 11 – Fuel Priming Lever | 24 – Exhaust Manifold |
| 12 – Dipstick (Engine Oil) | 25 – Alternator |
| 13 – Engine Oil Filter | |

* Engine oil drain plug location may vary based on oil pan options.

LOCATION OF LABELS

Figure 4-2 shows the location of regulatory and safety labels on Yanmar TNV series engines.

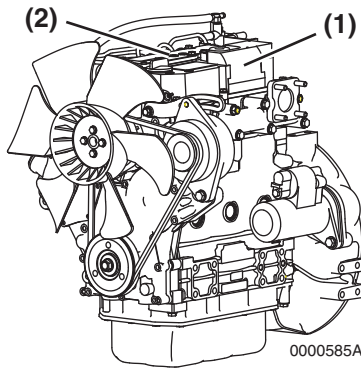
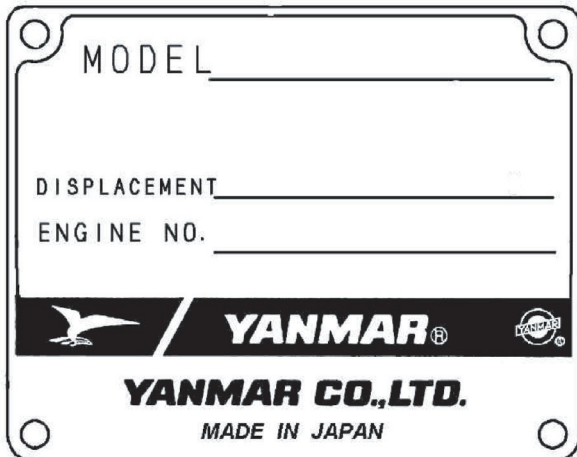

Figure 4-2

The typical location of the emission control information label is shown (Figure 4-2, (1)).

Typical location of the engine nameplate is shown (Figure 4-2, (2)).

Engine Nameplate (Typical)



0003852

EPA / ARB EMISSION CONTROL REGULATIONS - USA ONLY

Yanmar TNV engines meet Environmental Protection Agency (EPA) (U. S. Federal) emission control standards as well as the California Air Resources Board (ARB, California) regulations. Only engines that conform to ARB regulations can be sold in the State of California.

Refer to the specific EPA / ARB installation (page 5-16) and maintenance (page 5-16) in the *Periodic Maintenance* section of this manual. Also refer to the *Yanmar Co., Ltd. Limited Emission Control System Warranty - USA Only Yanmar Co., Ltd. Limited Emission Control System Warranty - USA Only* on page 2-6.

EMISSION CONTROL LABELS

Since emission control regulations are being issued on a global basis, it is necessary to identify which regulations a particular engine complies with. We have listed several different types of labels you might find on your engine.

EPA / CARB Labels (Typical)

EMISSION CONTROL INFORMATION	
THIS ENGINE COMPLIES WITH U.S. EPA REGULATIONS FOR <input type="checkbox"/> M. Y. NONROAD DIESEL ENGINES. LOW SULFUR FUEL OR ULTRA LOW SULFUR FUEL ONLY	
ENGINE FAMILY : <input type="text"/>	DISPLACEMENT : <input type="text"/> LITERS
ENGINE MODEL : <input type="text"/>	EMISSION CONTROL SYSTEM : <input type="text"/>
FUEL RATE : <input type="text"/> MM ³ /STROKE @ <input type="text"/> kW / <input type="text"/> RPM <input type="text"/>	
REFER TO OWNER'S MANUAL FOR MAINTENANCE SPECIFICATIONS AND ADJUSTMENTS	
YANMAR YANMAR CO.,LTD.	

021751-00X

(EPA)

EMISSION CONTROL INFORMATION	
THIS ENGINE COMPLIES WITH U. S. EPA AND CALIFORNIA REGULATIONS FOR <input type="checkbox"/> M. Y. NONROAD/OFF-ROAD DIESEL ENGINES. LOW SULFUR FUEL OR ULTRA LOW SULFUR FUEL ONLY	
ENGINE FAMILY : <input type="text"/>	DISPLACEMENT : <input type="text"/> LITERS
ENGINE MODEL : <input type="text"/>	EMISSION CONTROL SYSTEM : <input type="text"/>
FUEL RATE : <input type="text"/> MM ³ /STROKE @ <input type="text"/> kW / <input type="text"/> RPM <input type="text"/>	
REFER TO OWNER'S MANUAL FOR MAINTENANCE SPECIFICATIONS AND ADJUSTMENTS	
YANMAR YANMAR CO.,LTD.	

021752-00X

(EPA & CARB)

THE 97/68/EC DIRECTIVE CERTIFIED ENGINES

The engines described in this manual have been certified by the 97/68/EC Directive.

To identify the engines that meet this certification, the 97/68/EC emission control label is affixed on the engines.

IMPORTANT ENGINE INFORMATION	
THIS ENGINE CONFORMS TO 97/68/EC DIRECTIVE	
ENGINE FAMILY :	<input type="text"/>
ENGINE MODEL :	<input type="text"/>
APPROVAL NUMBER :	<input type="text"/>
 YANMAR CO.,LTD.	

(97/68/EC)

ENGINE FAMILY

The EPA / ARB labels and the 97/68/EC label all have an *Engine Family* field. The following is an explanation of the *Engine Family* designation:

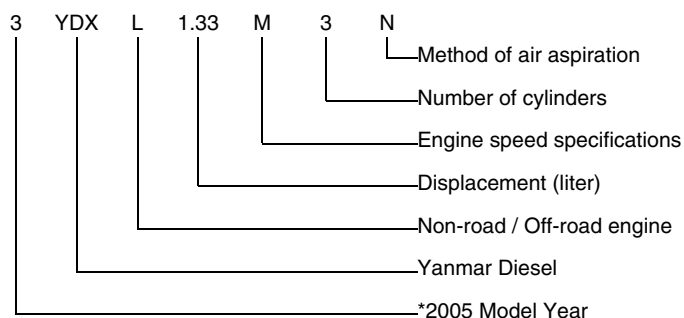

5*: 2005

6 : 2006

7 : 2007

FUNCTION OF MAJOR ENGINE COMPONENTS

Component	Function
Air Cleaner	The air cleaner prevents airborne contaminants from entering the engine. Since the air cleaner is application specific, it must be carefully selected by an application engineer. It is not part of the basic engine package as shipped from the Yanmar factory. Periodic replacement of the air cleaner filter element is necessary. See the <i>Periodic Maintenance Schedule on page 5-16</i> for the replacement frequency.
Dynamo	The dynamo is driven by a V-belt which is powered by the crankshaft V-pulley. The dynamo supplies electricity to the engine systems and charges the battery while the engine is running.
Dipstick (Engine Oil)	The engine oil dipstick is used to determine the amount of engine oil in the crankcase.
Electric Fuel Pump	The electric fuel pump makes sure there is a constant supply of diesel fuel to the fuel injection pump. The electric fuel pump is electro-magnetic and runs on 12 VDC. An electric fuel pump may be installed as standard equipment based on engine model and specification. If an electric fuel pump is installed, turn the key switch to the ON position for 10 to 15 seconds to prime the fuel system.
Engine Oil Filter	The engine oil filter removes contaminants and sediments from the engine oil. Periodic replacement of the engine oil filter is necessary. See the <i>Periodic Maintenance Schedule on page 5-16</i> for the replacement frequency.
Fuel Filter	The fuel filter removes contaminants and sediments from the diesel fuel. Periodic replacement of the fuel filter is necessary. See the <i>Periodic Maintenance Schedule on page 5-16</i> for the replacement frequency. Please note that the word “diesel” is implied throughout this manual when the word “fuel” is used.
Fuel Filter / Water Separator	The fuel filter / water separator removes contaminants, sediments and water from diesel fuel going to the fuel filter. This is a required component of the fuel system. This is standard equipment with every engine. The separator is installed between the fuel tank and the fuel pump. Periodically drain the water from the fuel filter / water separator using the drain cock at the bottom of the separator.
Fuel Priming Lever	If the unit has a mechanical fuel pump, a fuel priming lever on the mechanical fuel pump primes the fuel system. The fuel system needs to be primed before you start the engine for the first time, if you run out of fuel, or if fuel system service is performed. To prime the fuel system, operate the fuel priming lever until the cup in the fuel filter is full of fuel.

Component	Function
Fuel Tank	The fuel tank is a reservoir that holds diesel fuel. When fuel leaves the fuel tank it goes to the fuel filter / water separator. Next, fuel is pumped to the fuel filter by the fuel pump. Next the fuel goes to the fuel injection pump. Since fuel is used to keep the fuel injection pump cool and lubricated, more fuel than necessary enters the injection pump. When the injection pump pressure reaches a preset value, a relief valve allows excess fuel to be returned back to the fuel tank. The fuel tank is a required engine component.
Mechanical Fuel Pump	The mechanical fuel pump is a diaphragm type of pump and is installed on the fuel injection pump body. The mechanical fuel pump is standard equipment on some engine models and is driven by a cam on the camshaft of the fuel injection pump. The mechanical fuel pump is not installed on the fuel injection pump if the electric fuel pump is installed.
Side and Top Filler Port (Engine Oil)	You can fill the crankcase with engine oil from <i>either the side or top filler port</i> depending upon which one is most convenient.
Starter Motor	The starter motor is powered by the battery. When you turn the key switch in the operator's console to the START position, the starter motor engages with the ring gear installed on the flywheel and starts the flywheel in motion.

FUNCTION OF COOLING SYSTEM COMPONENTS

Component	Function
Cooling System	The TNV engine is liquid-cooled by means of a cooling system. The cooling system consists of a radiator, radiator cap, engine cooling fan, engine coolant pump, thermostat, and reserve tank. Note that all cooling system components are required for proper engine operation. Since some of the components are application specific, they must be carefully selected by an application engineer. The application specific items are not part of the basic engine package as shipped from the Yanmar factory.
Engine Cooling Fan	The engine cooling fan is driven by a V-belt which is powered by the crankshaft V-pulley. The purpose of the engine cooling fan is to circulate air through the radiator.
Engine Coolant Pump	The engine coolant pump circulates the engine coolant through the cylinder block and cylinder head and returns the engine coolant to the radiator.
Radiator	The radiator acts as a heat exchanger. As the engine coolant circulates through the cylinder block it absorbs heat. The heat in the engine coolant is dissipated in the radiator. As the engine cooling fan circulates air through the radiator, the heat is transferred to the air.
Radiator Cap	The radiator cap controls the cooling system pressure. The cooling system is pressurized to raise the boiling point of the engine coolant. As the engine coolant temperature rises, the system pressure and the coolant volume increases. When the pressure reaches a preset value, the release valve in the radiator cap opens and the excess engine coolant flows into the reserve tank. As the engine coolant temperature is reduced, the system pressure and volume is reduced and the vacuum valve in the radiator cap opens allowing engine coolant to flow from the reserve tank back into the radiator.
Reserve Tank	The reserve tank contains the overflow of engine coolant from the radiator. If you need to add engine coolant to the system, add it to the reserve tank, not to the radiator.
Thermostat	A thermostat is placed in the cooling system to prevent engine coolant from circulating into the radiator until the engine coolant temperature reaches a preset temperature. When the engine is cold, no engine coolant flows through the radiator. Once the engine reaches its operating temperature the thermostat opens. By letting the engine warm up as quickly as possible, the thermostat reduces engine wear, deposits and emissions.

DIESEL FUEL

Diesel Fuel Specifications

Diesel fuel should comply with the following specifications. The table lists several worldwide specifications for diesel fuels.

Diesel Fuel Specification	Location
ASTM D975 No. 1D S15, S500 No. 2D S15, S500	USA
EN590:96	European Union
ISO 8217 DMX	International
BS 2869-A1 or A2	United Kingdom
JIS K2204 Grade No. 2	Japan
KSM-2610	Korea
GB252	China

Additional Technical Fuel Requirements

- The fuel cetane number should be equal to 45 or higher.
- The sulfur content must not exceed 0.5% by volume. Less than 0.05% is preferred. Especially in U.S.A. and Canada, Low Sulfur (300-500mg/kg sulfur content) or Ultra Low Sulfur fuel should be used.
- Bio-Diesel fuels. See *Bio-Diesel Fuels on page 4-9*.
- NEVER mix kerosene, used engine oil, or residual fuels with the diesel fuel.
- Water and sediment in the fuel should not exceed 0.05% by volume.
- Keep the fuel tank and fuel-handling equipment clean at all times.
- Poor quality fuel can reduce engine performance and / or cause engine damage.
- Fuel additives are not recommended. Some fuel additives may cause poor engine performance. Consult your Yanmar representative for more information.
- Ash content not to exceed 0.01% by volume.

- Carbon residue content not to exceed 0.35% by volume. Less than 0.1% is preferred.
- Total aromatics content should not exceed 35% by volume. Less than 30% is preferred.
- PAH (polycyclic aromatic hydrocarbons) content should be below 10% by volume.
- Metal content of Na, Mg, Si, and Al should be equal to or lower than 1 mass ppm. (Test analysis method JPI-5S-44-95)
- Lubricity: Wear mark of WS1.4 should be Max. 0.018 in. (460 µm) at HFRR test.

Bio-Diesel Fuels

In Europe and in the United States, as well as some other countries, non-mineral oil based fuel resources such as RME (Rapeseed Methyl Ester) and SOME (Soybean Methyl Ester), collectively known as FAME (Fatty Acid Methyl Esters), are being used as extenders for mineral oil derived diesel fuels.

Yanmar approves the use of bio-diesel fuels that do not exceed a blend of 5% (by volume) of FAME with 95% (by volume) of approved mineral oil derived diesel fuel. Such bio-diesel fuels are known in the marketplace as B5 diesel fuels.

These B5 diesel fuels must meet certain requirements.

1. The bio-fuels must meet the minimum specifications for the country in which they are used.
 - In Europe, bio-diesel fuels must comply with the European Standard EN14214.
 - In the United States, bio-diesel fuels must comply with the American Standard ASTM D-6751.
2. Bio-fuels should be purchased only from recognized and authorized diesel fuel suppliers.

Precautions and concerns regarding the use of bio-fuels:

1. Free methanol in FAME may result in corrosion of aluminum and zinc FIE components.
2. Free water in FAME may result in plugging of fuel filters and increased bacterial growth.
3. High viscosity at low temperatures may result in fuel delivery problems, injection pump seizures, and poor injection nozzle spray atomization.
4. FAME may have adverse effects on some elastomers (seal materials) and may result in fuel leakage and dilution of the engine lubricating oil.
5. Even bio-diesel fuels that comply with a suitable standard as delivered, will require additional care and attention to maintain the quality of the fuel in the equipment or other fuel tanks. It is important to maintain a supply of clean, fresh fuel. Regular flushing of the fuel system, and / or fuel storage containers, may be necessary.
6. The use of bio-diesel fuels that do not comply with the standards as agreed to by the diesel engine manufacturers and the diesel fuel injection equipment manufacturers, or bio-diesel fuels that have degraded as per the precautions and concerns above, may affect the warranty coverage of your engine. See *Yanmar Limited Warranty on page 2-3.*

Filling the Fuel Tank**⚠ DANGER****FIRE AND EXPLOSION HAZARD!**

- Diesel fuel is flammable and explosive under certain conditions.
- Only fill the fuel tank with diesel fuel. Filling the fuel tank with gasoline may result in a fire and will damage the engine.
- NEVER refuel with the engine running.
- Wipe up all spills immediately.
- Keep sparks, open flames or any other form of ignition (match, cigarette, static electric source) well away when refueling.
- NEVER overfill the fuel tank.
- Fill the fuel tank. Store any containers containing fuel in a well-ventilated area, away from any combustibles or sources of ignition.
- Failure to comply will result in death or serious injury.

000005en

⚠ DANGER**FIRE AND EXPLOSION HAZARD!**

- Diesel fuel is flammable and explosive under certain conditions.
- Be sure to place the diesel fuel container on the ground when transferring the diesel fuel from the pump to the container. Hold the hose nozzle firmly against the side of the container while filling it. This prevents static electricity buildup which could cause sparks and ignite fuel vapors.
- NEVER place diesel fuel or other flammable material such as oil, hay or dried grass close to the engine during engine operation or shortly after shutdown.
- Failure to comply will result in death or serious injury.

0000014en

⚠ DANGER**FIRE AND EXPLOSION HAZARD!**

- Diesel fuel is flammable and explosive under certain conditions.
- Before you operate the engine, check for fuel leaks. Replace rubberized fuel hoses every two years or every 2000 hours of engine operation, whichever comes first, even if the engine has been out of service. Rubberized fuel lines tend to dry out and become brittle after two years or 2000 hours of engine operation, whichever comes first.
- Failure to comply will result in death or serious injury.

0000015en

CAUTION

- Only use diesel fuels recommended by Yanmar for the best engine performance, to prevent engine damage and to comply with EPA / ARB warranty requirements.
- Only use clean diesel fuel.
- NEVER remove the primary strainer (if equipped) from the fuel tank filler port. If removed, dirt and debris could get into the fuel system causing it to clog.

0000004en

Note that a typical fuel tank is shown. The fuel tank on the equipment being serviced may be different.

1. Clean the area around the fuel cap (Figure 4-3, (1)).
2. Remove the fuel cap (Figure 4-3, (1)) from the fuel tank (Figure 4-3, (2)).
3. Observe the fuel level sight gauge (Figure 4-3, (3)) and stop fueling when gauge shows fuel tank is full. NEVER overfill the fuel tank.
4. Replace the fuel cap and hand-tighten. Over tightening the fuel cap will damage it.

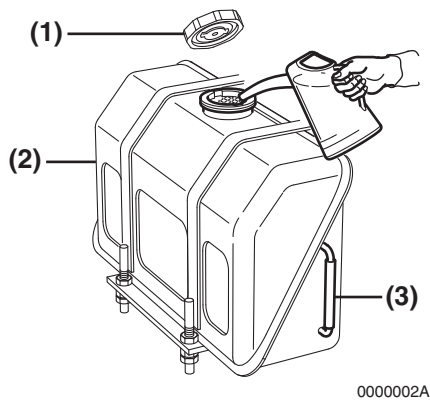

Figure 4-3

Priming the Fuel System

⚠ DANGER



FIRE AND EXPLOSION HAZARD!

- Diesel fuel is flammable and explosive under certain conditions.
- If the unit has an electric fuel pump, when you prime the fuel system, turn the key switch to the ON position for 10 to 15 seconds to allow the electric fuel pump to prime the system.
- If the unit has a mechanical fuel pump, when you prime the fuel system, operate the fuel priming lever of the mechanical fuel pump several times until the fuel filter cup is filled with fuel.
- Failure to comply will result in death or serious injury.

000010en

The fuel system needs to be primed under certain conditions:

- Before starting the engine for the first time
- After running out of fuel and fuel has been added to the fuel tank
- After fuel system maintenance such as changing the fuel filter and draining the fuel filter / water separator, or replacing a fuel system component

To prime the fuel system if an electric fuel pump is installed:

1. Turn the key to the ON position for 10 to 15 seconds. This will allow the electric fuel pump to prime the fuel system.
2. NEVER use the starter motor to prime the fuel system. This may cause the starter motor to overheat and damage the coils, pinion and / or ring gear.

To prime the fuel system if a mechanical fuel pump is installed:

1. Operate the fuel priming lever (**Figure 4-4, (1)**) several times until the fuel filter cup (**Figure 4-4, (2)**) is filled with fuel.
2. NEVER use the starter motor to prime the fuel system. This may cause the starter motor to overheat and damage the coils, pinion and / or ring gear.

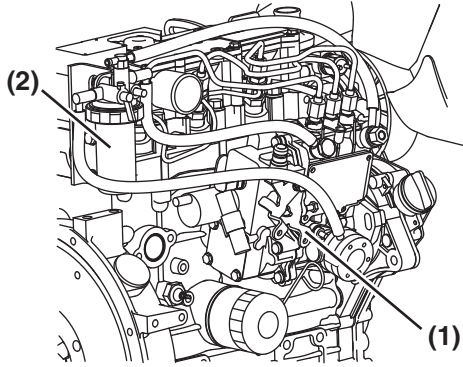

0000649A

Figure 4-4

ENGINE OIL

CAUTION

- Only use the engine oil specified. Other engine oils may affect warranty coverage, cause internal engine components to seize and / or shorten engine life.
- Prevent dirt and debris from contaminating the engine oil. Carefully clean the oil cap / dipstick and the surrounding area before you remove the cap.
- NEVER mix different types of engine oil. This may adversely affect the lubricating properties of the engine oil.
- NEVER overfill. Overfilling may result in white exhaust smoke, engine overspeed or internal damage.

0000005en

Engine Oil Specifications

Use an engine oil that meets or exceeds the following guidelines and classifications:

Service Categories

- API Service Categories CD or higher
- ACEA Service Categories E-3, E-4, and E-5
- JASO Service Category DH-1

Definitions

- API Classification (American Petroleum Institute)
- ACEA Classification (Association des Constructeurs Européens d'Automobilies)
- JASO (Japanese Automobile Standards Organization)

Note:

1. Be sure the engine oil, engine oil storage containers, and engine oil filling equipment are free of sediments and water.

2. Change the engine oil after the first 50 hours of operation and then every 250 hours thereafter.
3. Select the oil viscosity based on the ambient temperature where the engine is being operated. See the SAE Service Grade Viscosity Chart (**Figure 4-5**).
4. Yanmar does not recommend the use of engine oil “additives.”

Additional Technical Engine oil Requirements:

The engine oil must be changed when the Total Base Number (TBN) has been reduced to 1.0 (mgKOH/g) test method; JIS K-201-5.2-2 (HCl), ASTM D4739 (HCl).

Engine Oil Viscosity

Select the appropriate engine oil viscosity based on the ambient temperature and use the SAE Service Grade Viscosity Chart in **Figure 4-5**.

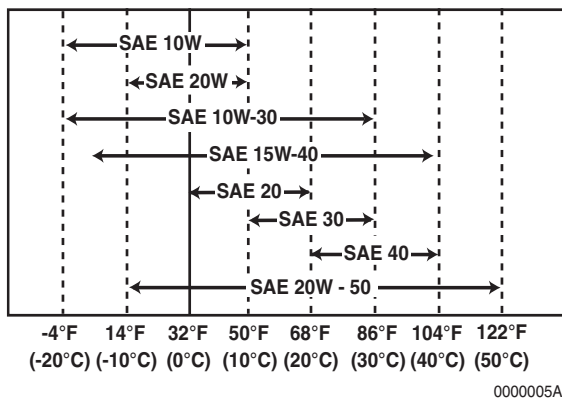

Figure 4-5

Checking Engine Oil

1. Make sure engine is level.
2. Remove dipstick (**Figure 4-6, (1)**) and wipe with clean cloth.
3. Fully reinsert dipstick.
4. Remove dipstick. The oil level should be between upper (**Figure 4-6, (2)**) and lower (**Figure 4-6, (3)**) lines on the dipstick.
5. Fully reinsert dipstick.

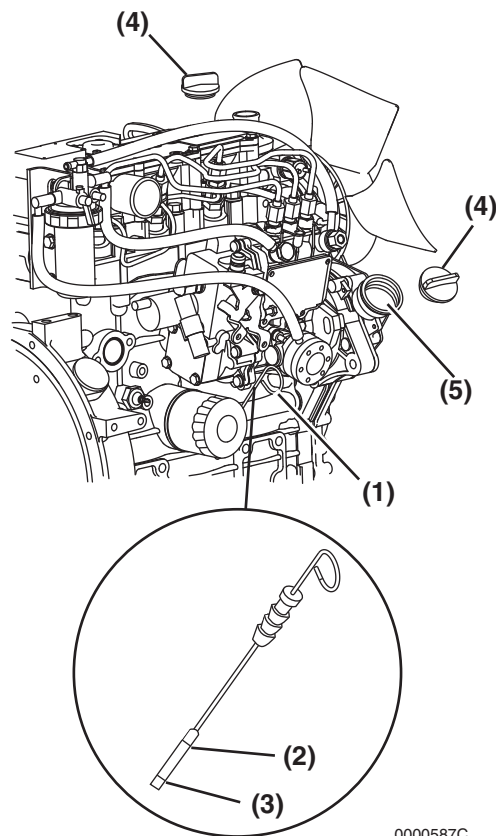

Figure 4-6

Adding Engine Oil

1. Make sure engine is level.
2. Remove oil cap (**Figure 4-6, (4)**).
3. Add indicated amount of engine oil at the top or side engine oil filler port (**Figure 4-6, (5)**).
4. Wait three minutes and check oil level.
5. Add more oil if necessary.
6. Replace oil cap (**Figure 4-6, (4)**) and hand-tighten. Over-tightening may damage the cap.

Engine Oil Capacity (Typical)

Note: These are the engine oil capacities associated with a “deep standard” oil pan. Oil capacity will vary dependant upon which optional oil pan is used. Refer to the operation manual provided by the driven machine manufacturer for the actual engine oil capacity of your machine.

The following are the engine oil capacities for various Yanmar TNV engines:

Engine Model	Dipstick Upper Limit/ Lower Limit
2TNV70(VM) 2TNV70(VH)	1.9 / 1.3 qt (1.8 / 1.2 L)
2TNV70(CH)	2.3 / 1.3 qt (2.2 / 1.2 L)
3TNV70(CL), 3TNV70(VM) 3TNV70(VH)	3.0 / 1.6 qt (2.8 / 1.5 L)
3TNV70(CH)	4.0 / 2.2 qt (3.8 / 2.1 L)
3TNV76(CL), 3TNV76(VM) 3TNV76(VH)	3.6 / 1.9 qt (3.4 / 1.8 L)
3TNV76(CH)	4.7 / 2.4 qt (4.4 / 2.3 L)

ENGINE COOLANT



DANGER



SCALD HAZARD!

- **NEVER** remove the radiator cap if the engine is hot. Steam and hot engine coolant will spurt out and seriously burn you. Allow the engine to cool down before you attempt to remove the radiator cap.
- **Tighten** the radiator cap securely after you check the radiator. Steam can spurt out during engine operation if the cap is loose.
- **ALWAYS** check the level of the engine coolant by observing the reserve tank.
- **Failure to comply will result in death or serious injury.**

000002en



WARNING



BURN HAZARD!

- **Wait** until the engine cools before you drain the engine coolant. Hot engine coolant may splash and burn you.
- **Failure to comply could result in death or serious injury.**

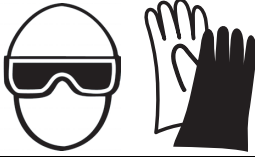
0000016en

CAUTION**COOLANT HAZARD!**

- Wear eye protection and rubber gloves when you handle long life or extended life engine coolant. If contact with the eyes or skin should occur, flush eyes and wash immediately with clean water.
- Failure to comply may result in minor or moderate injury.

000005en

CAUTION

- Only use the engine coolant specified. Other engine coolants may affect warranty coverage, cause an internal buildup of rust and scale and / or shorten engine life.
- Prevent dirt and debris from contaminating the engine coolant. Carefully clean the radiator cap and the surrounding area before you remove the cap.
- NEVER mix different types of engine coolants. This may adversely affect the properties of the engine coolant.

000006en

Engine Coolant Specifications

Use a Long Life Coolant (LLC) or an Extended Life Coolant (ELC) that meets or exceeds the following guidelines and specifications:

Additional Technical Coolant Specifications:

- ASTM D6210, D4985 (US)
- JIS K-2234 (Japan)
- SAE J814C, J1941, J1034 or J2036 (International)

Alternative Engine Coolant

If an Extended or Long Life Coolant is not available, you may use an ethylene glycol or propylene glycol based conventional coolant (green).

Notes:

1. ALWAYS use a mix of coolant and water. NEVER use water only.
2. Mix coolant and water per the mixing instructions on the coolant container.
3. Water quality is important to coolant performance. Yanmar recommends that soft, distilled, or demineralized water be used to mix with coolants.
4. NEVER mix extended or long life coolants and conventional (green) coolants.
5. NEVER mix different types and / or colors of extended life coolants.
6. Replace the coolant every 1000 engine hours or once a year.

Filling Radiator with Engine Coolant

Fill the radiator and reserve tank as follows. This procedure is for filling the radiator for the first time or refilling it after it is flushed. Note that a typical radiator is illustrated.

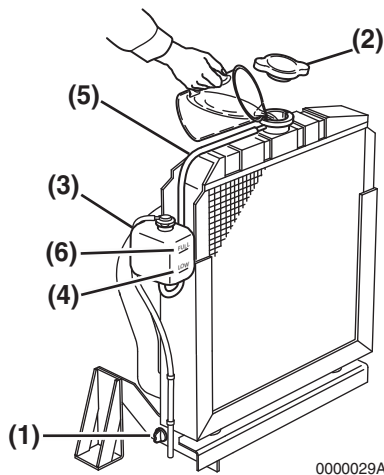

Figure 4-7

1. Check to be sure the radiator drain plug is installed and tightened or the drain cock (Figure 4-7, (1)) is closed. Also make sure the coolant drain plug (Figure 4-8, (1)) in the cylinder block is closed.

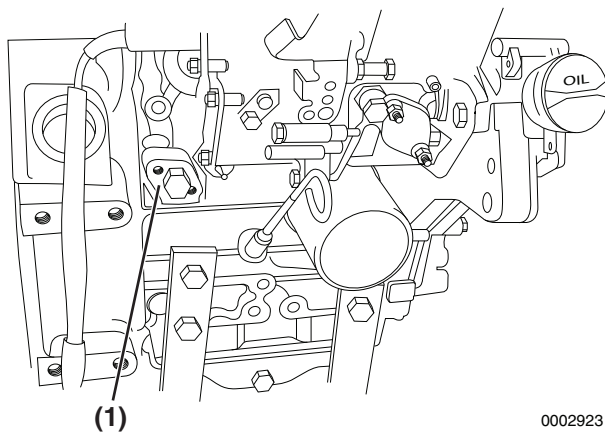

Figure 4-8

2. Remove the radiator cap (Figure 4-7, (2)) by turning it counterclockwise about 1/3 of a turn.
3. Pour the engine coolant *slowly* into the radiator until it is even with the lip of the engine coolant filler port. Make sure that air bubbles do not develop as you fill the radiator.
4. Reinstall the radiator cap (Figure 4-7, (2)). Align the tabs on the back of the radiator cap with the notches on the engine coolant filler port. Press down and turn the cap clockwise about 1/3 of a turn.

5. Remove the cap of the reserve tank (Figure 4-7, (3)), and fill it to the LOW (COLD) mark (Figure 4-7, (4)) with engine coolant. Reinstall the cap.
6. Check the hose (Figure 4-7, (5)) that connects the reserve tank (Figure 4-7, (3)) to the radiator. Be sure it is securely connected and there are no cracks or damage. If the hose is damaged, engine coolant will leak out instead of going into the reserve tank.
7. Run the engine until it is at operating temperature. Check the level of engine coolant in the reserve tank. When the engine is running and the engine coolant is at normal temperature, the coolant level in the tank should be at or near the FULL (HOT) mark (Figure 4-7, (6)). If the engine coolant is not at the FULL (HOT) mark (Figure 4-7, (6)), add additional engine coolant to the reserve tank to bring the level to the FULL (HOT) mark.

Engine Coolant Capacity (Typical)

Note: Capacities listed are for engine only without a radiator. Refer to the operation manual provided by the driven machine manufacturer for actual engine coolant capacity on your machine.

The following are the engine coolant capacities for various Yanmar TNV engines.

Engine Model	Engine Coolant Capacity
2TNV70	0.6 qt (0.6 L)
3TNV70	1.0 qt (0.9 L)
3TNV76	1.0 qt (0.9 L)

SPECIFICATIONS

Description of Model Number

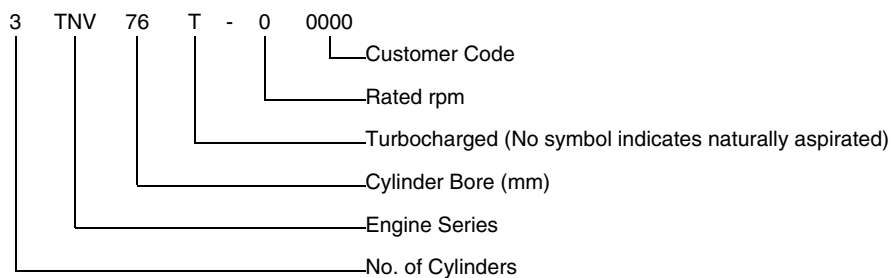

When ordering parts or making an inquiry about the engine you are working on, be sure to include the complete model and serial numbers as shown on the engine nameplate. See *Location of Labels on page 4-4*.

Engine Speed Specifications

Notation	Available Engine Speed	Intended Uses
VH	3200 ~ 3600 rpm (min ⁻¹)	Lawn Mower, Construction, Industrial Machine
VM	2000 ~ 3000 rpm (min ⁻¹)	Agricultural, Constructive, Industrial Machines
CH	3000 ~ 3600 rpm (min ⁻¹)	2-pole Generator Sets, Irrigation Pumps
CL	1500 or 1800 rpm (min ⁻¹)	4-pole Generator Sets, Irrigation Pumps

VH: Variable High Speed

VM: Variable Medium Speed

CH: Constant High Speed

CL: Constant Low Speed

Engine General Specifications

Type	Vertical In-line, Water Cooled, 4-Cycle Diesel Engine
Combustion System	Swirl Chamber (Ball Type)
Starting System	Electric Starting
Cooling System	Radiator
Lubricating System	Forced Lubrication with Trochoid Pump
PTO Position	Flywheel End
Direction of Rotation	Counterclockwise Viewed from Flywheel End

Note: The information described in *Principal Engine Specifications* is for a “standard” engine. To obtain the information for the engine installed in your driven machine, please refer to the manual provided by the driven machine manufacturer. Engine rating conditions are as follows (SAE J1349, ISO 3046/1):

- Atmospheric Condition: Room temperature 77°F (25°C), Atmospheric pressure 29.53 in Hg (100 kPa, 750 mm Hg), Relative humidity 30%
- Fuel Temperature at Fuel Injector Pump Inlet: 104°F (40°C)
- With Cooling Fan, Air Cleaner, Muffler: Yanmar Standard
- After Engine Break-In Period; Output Allowable Deviation: $\pm 3\%$
- 1 PS = 0.7355 kW
- 1 hp SAE (Society of Automotive Engineers) = 0.7457 kW

PRINCIPAL ENGINE SPECIFICATIONS

2TNV70

Engine Model	2TNV70												
Version	VM				CH				VH				
Type	Vertical In-line Diesel Engine												
Combustion System	Ball-Type Swirl Chamber												
Aspiration	Natural												
No. of Cylinders	2												
Bore × Stroke	2.756 x 2.913 in. (70 × 74 mm)												
Displacement	34.777 cu in. (0.570 L)												
Continuous Rated Output	RPM (min ⁻¹)							3000	3600				
	hp SAE							10.9	13.1				
	kW							8.16	9.76				
	PS							11.1	13.3				
Max. Rated Output (Net)	RPM (min ⁻¹)	2000	2200	2400	2600	2800	3000	3000	3600	3200	3400	3600	
	hp SAE	7.99	8.88	9.76	10.55	11.44	12.23	12.03	14.40	12.53	13.12	13.81	
	kW	5.96	6.62	7.28	7.87	8.53	9.12	8.97	10.7	9.34	9.78	10.3	
	PS	8.10	9.00	9.90	10.7	11.6	12.4	12.2	14.6	12.7	13.3	14.0	
High Idling	RPM (min ⁻¹)	2160 ± 25	2375 ± 25	2570 ± 25	2780 ± 25	2995 ± 25	3210 ± 25	3165 ± 25	3800 ± 25	3400 ± 25	3600 ± 25	3815 ± 25	
Engine Weight (Dry) with Flywheel Housing	182.2 lb (84 kg)												
PTO Position	Flywheel End												
Direction of Rotation	Counterclockwise Viewed From Flywheel End												
Cooling System	Liquid-Cooled with Radiator												
Lubricating System	Forced Lubrication with Trochoid Pump												
Normal Oil Pressure at Rated Engine Speed	42 - 64 psi (0.29 - 0.44 MPa, 2.96 - 4.49 kgf/cm ²)												
Normal Oil Pressure at Low Idle Speed	8.5 psi (0.06 MPa, 0.6 kgf/cm ²) or greater												
Starting System	Electric Starting - Starter Motor: DC12V, 1.3 hp (1.0 kW)**												
	Dynamo: DC12V, 20A**												
	Recommended Battery Capacity: 12V, 36 Amp-Hour (5h rating)**												
Dimensions (L × W × H)*	16.38 x 16.81 x 19.06 in. (419 x 427 x 484 mm)						16.38 x 16.81 x 20.24 in. (416 x 427 x 514 mm)			16.38 x 16.81 x 19.06 in. (416 x 427 x 484 mm)			
Engine Oil Pan Capacity	1.7 / 0.9 qt (1.65 / 0.8 L) (Dipstick Upper Limit / Lower Limit)						2.4 / 1.4 qt (2.3 / 1.3 L) (Dipstick Upper Limit / Lower Limit)			1.7 / 0.8 qt (1.6 / 0.8 L) (Dipstick Upper Limit / Lower Limit)			
Engine Coolant Capacity	0.2 gal (0.9 L) Engine Only												
Standard Cooling Fan	10.23 in. (260 mm) O.D., 5 Blade Pusher-Type**												

* Engine specifications without radiator.

** May vary depending on application.

*** Engine oil capacity for a "Deep Standard" oil pan. Refer to the operation manual provided by the driven machine manufacturer for the actual engine oil capacity of your machine.

3TNV70

Engine Model	3TNV70														
Version	CL			VM						CH		VH			
Type	Vertical In-line Diesel Engine														
Combustion System	Ball-Type Swirl Chamber														
Aspiration	Natural														
No. of Cylinders	3														
Bore x Stroke	2.756 x 2.913 in. (70 x 74 mm)														
Displacement	52.105 cu in. (0.854 L)														
Continuous Rated Output	RPM (min ⁻¹)	1500	1800							3000	3600				
	hp SAE	8.16	9.77							16.27	19.43				
	kW	6.09	7.29							8.16	9.76				
	PS	8.27	9.91							16.5	19.7				
Max. Rated Output (Net)	RPM (min ⁻¹)	1500	1800	2000	2200	2400	2600	2800	3000	3000	3600	3200	3400	3600	
	hp SAE	8.98	10.75	12.03	13.32	14.70	15.88	17.16	18.35	17.85	21.40	18.74	19.73	20.71	
	kW	6.69	8.02	8.97	9.93	11.0	11.8	12.8	13.7	13.3	16.0	14.0	14.7	15.4	
	PS	9.10	10.9	12.2	13.5	14.9	16.1	17.4	18.6	18.1	21.7	19.0	20.0	21.0	
High Idling	RPM (min ⁻¹)	1600 ± 25	1895 ± 25	2160 ± 25	2375 ± 25	2570 ± 25	2780 ± 25	2995 ± 25	3210 ± 25	3165 ± 25	3800 ± 25	3400 ± 25	3600 ± 25	3815 ± 25	
Engine Weight (Dry) with Flywheel Housing	216.1 lb (98 kg)														
PTO Position	Flywheel End														
Direction of Rotation	Counterclockwise Viewed from Flywheel End														
Cooling System	Liquid-Cooled with Radiator														
Lubricating System	Forced Lubrication with Trochoid Pump														
Normal Oil Pressure at Rated Engine Speed	35 - 51psi (0.24-0.35 MPa, 2.44 - 3.57 kgf/cm ²)		42 - 64 psi (0.29 -0.44 MPa, 2.96 - 4.49 kgf/cm ²)												
Normal Oil Pressure at Low Idle Speed	8.5 psi (0.06 MPa, 0.6 kgf/cm ²) or greater														
Starting System	Electric Starting - Starter Motor: DC12V, 1.3 hp (1.0 kW)**														
	Dynamo: DC12V, 20A**														
	Recommended Battery Capacity: 12V, 36 Amp-Hour (5h rating)**														
Dimensions (L x W x H)*	21.57 x 16.81 x 19.92 in. (548 x 427 x 506 mm)		19.84 x 16.81 x 19.92 in. (504 x 427 x 506 mm)						19.84 x 16.81 x 21.10 in. (504 x 427 x 536 mm)		19.84 x 16.81 x 19.92 in. (504 x 427 x 506 mm)				
Engine Oil Pan Capacity	3.0 / 1.6 qt (2.8 / 1.5 L) (Dipstick Upper Limit / Lower Limit)								4.0 / 2.2 qt (3.8 / 2.1 L) (Dipstick Upper Limit / Lower Limit)		3.0 / 1.6 qt (2.8 / 1.5 L) (Dipstick Upper Limit / Lower Limit)				
Engine Coolant Capacity	0.2 gal (0.9 L) Engine Only														
Standard Cooling Fan	12.20 in. (310 mm) O.D., 5 Blade Pusher-Type**														

* Engine specifications without radiator

** May vary depending on application.

*** Engine oil capacity for a "Deep Standard" oil pan. Refer to the operation manual provided by the driven machine manufacturer for the actual engine oil capacity of your machine.

3TNV76

Engine Model	3TNV76															
Version	CL			VM						CH		VH				
Type	Vertical In-line Diesel Engine															
Combustion System	Ball-Type Swirl Chamber															
Aspiration	Natural															
No. of Cylinders	3															
Bore x Stroke	2.992 x 3.228 in. (76 x 82 mm)															
Displacement	68.029 cu in. (1.115 L)															
Continuous Rated Output	RPM (min ⁻¹)	1500	1800							3000	3600					
	hp SAE	11.0	13.1							20.2	23.7					
	kW	8.2	9.8							15.1	17.7					
	PS	11.1	13.3							20.5	24.1					
Max. Rated Output (Net)	RPM (min ⁻¹)	1500	1800	2000	2200	2400	2500	2600	2800	3000	3000	3600	3200	3400	3600	
	hp SAE	12.1	14.3	15.9	17.7	19.2	20.0	20.8	22.4	24.0	22.1	26.1	24.4	25.9	26.1	
	kW	9	10.7	11.8	13.2	14.3	14.9	15.5	16.7	17.9	16.5	19.5	18.2	19.3	19.5	
	PS	12.2	14.5	16.1	17.9	19.5	20.3	21.1	22.7	24.3	22.4	26.5	24.7	26.2	26.5	
High Idling	RPM (min ⁻¹)	1600 ± 25	1900 ± 25	2160 ± 25	2375 ± 25	2570 ± 25	2675 ± 25	2780 ± 25	2995 ± 25	3210 ± 25	3200 ± 25	3800 ± 25	3400 ± 25	3600 ± 25	3815 ± 25	
Engine Weight (Dry) with Flywheel Housing	247.0 lb (112 kg)															
PTO Position	Flywheel End															
Direction of Rotation	Counterclockwise Viewed from Flywheel End															
Cooling System	Liquid-Cooled with Radiator															
Lubricating System	Forced Lubrication with Trochoid Pump															
Normal Oil Pressure at Rated Engine Speed	35 - 51psi (0.24-0.35 MPa, 2.44 - 3.57 kgf/cm ²)		42 - 64 psi (0.29 -0.44 MPa, 2.96 - 4.49 kgf/cm ²)													
Normal Oil Pressure at Low Idle Speed	8.5 psi (0.06 MPa, 0.6 kgf/cm ²) or greater															
Starting System	Electric Starting - Starter Motor: DC12V, 1.5 hp (1.1 kW)**															
	Alternator: DC12V, 40A**															
	Recommended Battery Capacity: 12V, 36 Amp-Hour (5h rating)**															
Dimensions (L x W x H)*	22.32 x 16.81 x 20.94 in. (567 x 427 x 532 mm)		20.59 x 16.81 x 20.94 in. (532 x 427 x 532 mm)						20.59 x 16.81 x 22.01 in. (532 x 427 x 559 mm)		20.59 x 16.81 x 20.94 in. (532 x 427 x 532 mm)					
Engine Oil Pan Capacity	3.6 / 1.9 qt (3.4 / 1.8 L) (Dipstick Upper Limit / Lower Limit)									4.7 / 2.4 qt (4.4 / 2.3 L) (Dipstick Upper Limit / Lower Limit)		3.6 / 1.9 qt (3.4 / 1.8 L) (Dipstick Upper Limit / Lower Limit)				
Engine Coolant Capacity	0.2 gal (0.9 L) Engine Only															
Standard Cooling Fan	13.19 in. (335 mm) O.D., 6 Blade Pusher-Type**															

* Engine specifications without radiator

** May vary depending on application.

*** Engine oil capacity for a "Deep Standard" oil pan. Refer to the operation manual provided by the driven machine manufacturer for the actual engine oil capacity of your machine.

ENGINE SERVICE INFORMATION

Inspection Item		Standard	Limit
Intake / Exhaust Valve Gap		0.006 - 0.010 in (0.15 - 0.25 mm)	-
Fuel Injection Timing	<i>See Checking and Adjusting Fuel Injection Timing on page 7-19</i>		
Fuel Injection Pressure		1711 - 1842 psi (11.8 - 12.8 MPa; 120 - 130 kgf / cm ²)	-
Compression Pressure at 250 rpm (250 min ⁻¹)	2TNV70 3TNV70	470 ± 15 psi (3.24 ± 0.1MPa; 33 ± 1 kgf / cm ²)	370 ± 15 psi (2.55 ± 0.1 MPa; 26 ± 1 kgf / cm ²)
	3TNV76	498 ± 15 psi (3.43 ± 0.1MPa, 35 ± 1 kgf / cm ²)	399 ± 15 psi (2.75 ± 0.1 MPa, 28 ± 1 kgf / cm ²)
Lubricating Oil Pressure	At rated output	42 - 64 psi (0.29 - 0.44 MPa; 2.96 - 4.49 kgf/cm ²)	-
	When idling	8.5 psi (0.06 MPa; 0.6 kgf/cm ²) or greater	-
Thermostat	Valve Opening Temperature		Full Opening Lift Temperature
	157 - 163°F (70 - 73°C)		0.32 in. (8 mm) or Above 185°F (85°C)
Temperature Coolant Switch		225 - 235°F (107 - 113°C)	-

TIGHTENING TORQUES FOR STANDARD BOLTS AND NUTS

Use the correct amount of torque when you tighten fasteners on the machine. Applying excessive torque may damage the fastener or component and not enough torque may cause a leak or component failure.

CAUTION

The tightening torque in the *Standard Torque Chart in General Service Information* should be applied only to the bolts with a “7” head. (JIS strength classification: 7T)

- Apply 60% torque to bolts that are not listed.
- Apply 80% torque when tightened to aluminum alloy.



0000023enTNVIDISM

Item	Nominal Thread Diameter x Pitch	Tightening Torque	Remarks
Hexagon Bolt (7T) and Nut	M6 x 1.0 mm	87 - 104 in·lb (9.8 - 11.8 N·m; 1.0 - 1.2 kgf·m)	Use 80% of the value at left when the tightening part is aluminum. Use 60% of the value at left for 4T bolts and lock nuts.
	M8 x 1.25 mm	200 - 251 in·lb (22.6 - 28.4 N·m; 2.3 - 2.9 kgf·m)	
	M10 x 1.5 mm	33 - 40 ft·lb (44.1 - 53.9 N·m; 4.5 - 5.5 kgf·m)	
	M12 x 1.75 mm	58 - 72 ft·lb (78.4 - 98.0 N·m; 8.0 - 10 kgf·m)	
	M14 x 1.5 mm	94 - 108 ft·lb (127.5 - 147.1 N·m; 13 - 15 kgf·m)	
	M16 x 1.5 mm	159 - 174 ft·lb (215.7 - 235.4 N·m; 22 - 24 kgf·m)	
PT Plug	1/8 mm	87 in·lb (9.8 N·m; 1.0 kgf·m)	-
	1/4 mm	173 in·lb (19.6 N·m; 2.0 kgf·m)	
	3/8 mm	22 ft·lb (29.4 N·m; 3.0 kgf·m)	
	1/2 mm	43 ft·lb (58.8 N·m; 6.0 kgf·m)	

Tightening Torques for Standard Bolts and Nuts **GENERAL SERVICE INFORMATION**

Item	Nominal Thread Diameter x Pitch	Tightening Torque	Remarks
Pipe Joint Bolt	M8	112 - 148 in·lb (12.7 - 16.7 N·m; 1.3 - 1.7 kgf·m)	-
	M10	173 - 225 in·lb (19.6 - 18.734 N·m,; 2.0 - 3.5 kgf·m)	
	M12	18 - 25 ft·lb (24.5 - 34.3 N·m; 2.5 - 3.5 kgf·m)	
	M14	29 - 36 ft·lb (39.2 - 49.0 N·m; 4.0 - 5.0 kgf·m)	
	M16	36 - 43 ft·lb (49.0 - 58.8 N·m; 5.0 - 6.0 kgf·m)	

Note: Torque values shown in this manual are for clean, non-lubricated fasteners unless otherwise specified.

ABBREVIATIONS AND SYMBOLS

Abbreviations

A	ampere
AC	alternating current
ACEA	Association des Constructeurs Européens d'Automobilies
Ah	ampere-hour
approx.	approximately
API	American Petroleum Institute
ARB	Air Resources Board
ATDC	after top dead center
BTDC	before top dead center
°C	degree Celsius
CARB	California Air Resources Board
CCA	cold cranking amp
cm	centimeter
cm ³	cubic centimeter
cm ³ /min	cubic centimeter per minute
cu in	cubic inch
DC	direct current
DI	direct injection
DVA	direct volt adapter
EPA	Environmental Protection Agency
ESG	electronic speed governor
°F	degree Fahrenheit
fl oz	fluid ounce (U.S.)
fl oz/min	fluid ounce (U.S.) per minute
ft	foot
ft-lb	foot pound
ft-lbf/min	foot pound force per minute
g	gram
gal/hr	gallon (U.S.) per hour
gal	gallon (U.S.)
GL	gear lubricant
hp	horsepower (U.S.)
hrs	hours
I.D.	inside diameter
IDI	indirect injection
in	inch
in-lb	inch pound
JASO	Japanese Automobile Standards Organization
kg	kilogram
kgf/cm ²	kilogram force per square centimeter
kgf-m	kilogram force meter
km	kilometers
kPa	kilopascal
kW	kilowatt

L	liter
L/hr	liter per hour
lb	pound
lbf	pond force
mL	milliliter
mm	millimeter
MPa	megapascal
mV	millivolt
N	newton
N-m	newton meter
No.	number
O.D.	outside diameter
oz	ounce
PS	horsepower (metric)
psi	pound per square inch
qt	quart (U.S.)
RPM	revolutions per minute
SAE	Society of Automotive Engineers
sec.	second
t	short ton 2000lb
TBN	Total Base Number
TDC	top dead center
V	volt
VAC	volt alternating current
VDC	volt direct current
W	watt

Symbols

°	angular degree
+	plus
-	minus
±	plus or minus
Ω	ohm
μ	micro
%	percent
~	approximate

UNIT CONVERSIONS

Unit Prefixes

Prefix	Symbol	Power
mega	M	x 1,000,000
kilo	k	x 1,000
centi	c	x 0.01
milli	m	x 0.001
micro	μ	x 0.000001

Units of Length

mile	x	1.6090	= km
ft	x	0.3050	= m
in	x	2.5400	= cm
in	x	25.4000	= mm
km	x	0.6210	= mile
m	x	3.2810	= ft
cm	x	0.3940	= in
mm	x	0.0394	= in

Units of Volume

gal (U.S.)	x	3.78540	= L
qt (U.S.)	x	0.94635	= L
cu in	x	0.01639	= L
cu in	x	16.38700	= mL
fl oz (U.S.)	x	0.02957	= L
fl oz (U.S.)	x	29.57000	= mL
cm ³	x	1.00000	= mL
cm ³	x	0.03382	= fl oz (U.S.)

Units of Mass

lb	x	0.45360	= kg
oz	x	28.35000	= g
kg	x	2.20500	= lb
g	x	0.03527	= oz

Units of Force

lbf	x	4.4480	= N
lbf	x	0.4536	= kgf
N	x	0.2248	= lbf
N	x	0.1020	= kgf
kgf	x	2.2050	= lbf
kgf	x	9.8070	= N

Units of Torque

ft·lb	x	1.3558	= N·m
ft·lb	x	0.1383	= kgf·m
in·lb	x	0.1130	= N·m
in·lb	x	0.0115	= kgf·m
kgf·m	x	7.2330	= ft·lb
kgf·m	x	86.8000	= in·lb
kgf·m	x	9.8070	= N·m
N·m	x	0.7376	= ft·lb
N·m	x	8.8510	= in·lb
N·m	x	0.1020	= kgf·m

Units of Pressure

psi	x	0.0689	= bar
psi	x	6.8950	= kPa
psi	x	0.0703	= kg/cm ²
bar	x	14.5030	= psi
bar	x	100.0000	= kPa
bar	x	29.5300	= in Hg (60°F)
kPa	x	0.1450	= psi
kPa	x	0.0100	= bar
kPa	x	0.0102	= kg/cm ²
kg/cm ²	x	98.0700	= psi
kg/cm ²	x	0.9807	= bar
kg/cm ²	x	14.2200	= kPa
in Hg (60°)	x	0.0333	= bar
in Hg (60°)	x	3.3770	= kPa
in Hg (60°)	x	0.0344	= kg/cm ²

Units of Power

hp (metric or PS)	x	0.9863201	= hp SAE
hp (metric or PS)	x	0.7354988	= kW
hp SAE	x	1.0138697	= hp (metric or PS)
hp SAE	x	0.7456999	= kW
kW	x	1.3596216	= hp (metric or PS)
kW	x	1.3410221	= hp SAE

Units of Temperature

$$^{\circ}\text{F} = (1.8 \times ^{\circ}\text{C}) + 32$$

$$^{\circ}\text{C} = 0.556 \times (^{\circ}\text{F} - 32)$$

This Page Intentionally Left Blank

Section 5

PERIODIC MAINTENANCE

	Page
Introduction.....	5-3
Precautions	5-15
The Importance of Periodic Maintenance.....	5-15
Performing Periodic Maintenance	5-15
Yanmar Replacement Parts	5-16
Required EPA / ARB Maintenance - USA Only.....	5-16
EPA / ARB Installation Requirements - USA Only	5-16
Periodic Maintenance Schedule.....	5-16
Periodic Maintenance Procedures	5-18
After Initial 50 Hours of Operation	5-18
Every 50 Hours of Operation	5-21
Every 250 Hours of Operation.....	5-25
Every 500 Hours of Operation.....	5-30
Every 1000 Hours of Operation.....	5-33
Every 1500 Hours of Operation.....	5-36
Every 2000 Hours of Operation.....	5-37

This Page Intentionally Left Blank

INTRODUCTION

This section of the *Service Manual* describes the procedures for proper care and maintenance of the engine.

! DANGER

<p style="text-align: center;">EXPLOSION HAZARD!</p> <ul style="list-style-type: none"> • NEVER check the remaining battery charge by shorting out the terminals. This will result in a spark and may cause an explosion or fire. Use a hydrometer to check the remaining battery charge. • If the electrolyte is frozen, slowly warm the battery before you recharge it. • Failure to comply will result in death or serious injury. <p style="text-align: right;">000007en</p>

! DANGER

<p style="text-align: center;">FIRE AND EXPLOSION HAZARD!</p> <ul style="list-style-type: none"> • Only use the key switch to start the engine. • NEVER jump-start the engine. Sparks caused by shorting the battery to the starter terminals may cause a fire or explosion. • Failure to comply will result in death or serious injury. <p style="text-align: right;">000004en</p>

! DANGER

<p style="text-align: center;">SCALD HAZARD!</p> <ul style="list-style-type: none"> • NEVER remove the radiator cap if the engine is hot. Steam and hot engine coolant will spurt out and seriously burn you. Allow the engine to cool down before you attempt to remove the radiator cap. • Tighten the radiator cap securely after you check the radiator. Steam can spurt out during engine operation if the cap is loose. • ALWAYS check the level of the engine coolant by observing the reserve tank. • Failure to comply will result in death or serious injury. <p style="text-align: right;">000002en</p>

⚠ DANGER**FIRE AND EXPLOSION HAZARD!**



- Diesel fuel is flammable and explosive under certain conditions.
- Only fill the fuel tank with diesel fuel. Filling the fuel tank with gasoline may result in a fire and will damage the engine.
- NEVER refuel with the engine running.
- Wipe up all spills immediately.
- Keep sparks, open flames or any other form of ignition (match, cigarette, static electric source) well away when refueling.
- NEVER overfill the fuel tank.
- Fill the fuel tank. Store any containers containing fuel in a well-ventilated area, away from any combustibles or sources of ignition.
- Failure to comply will result in death or serious injury.

000005en

⚠ DANGER**FIRE AND EXPLOSION HAZARD!**

- Diesel fuel is flammable and explosive under certain conditions.
- Before you operate the engine, check for fuel leaks. Replace rubberized fuel hoses every two years or every 2000 hours of engine operation, whichever comes first, even if the engine has been out of service. Rubberized fuel lines tend to dry out and become brittle after two years or 2000 hours of engine operation, whichever comes first.
- Failure to comply will result in death or serious injury.

000015en

 DANGER

<p>FIRE AND EXPLOSION HAZARD!</p> <ul style="list-style-type: none"> • Diesel fuel is flammable and explosive under certain conditions. • Be sure to place the diesel fuel container on the ground when transferring the diesel fuel from the pump to the container. Hold the hose nozzle firmly against the side of the container while filling it. This prevents static electricity buildup which could cause sparks and ignite fuel vapors. • NEVER place diesel fuel or other flammable material such as oil, hay or dried grass close to the engine during engine operation or shortly after shutdown. • Failure to comply will result in death or serious injury.
0000014en

 DANGER

<p>FIRE AND EXPLOSION HAZARD!</p> <ul style="list-style-type: none"> • Diesel fuel is flammable and explosive under certain conditions. • NEVER use diesel fuel as a cleaning agent. • Failure to comply will result in death or serious injury.
0000012en

 DANGER

<p>FIRE AND EXPLOSION HAZARD!</p> <ul style="list-style-type: none"> • Diesel fuel is flammable and explosive under certain conditions. • NEVER remove the fuel cap with the engine running. • Failure to comply will result in death or serious injury.
0000011en

 DANGER

<p>CRUSH HAZARD!</p> <ul style="list-style-type: none"> • When you need to transport an engine for repair, have a helper assist you to attach it to a hoist and load it on a truck. • NEVER stand under a hoisted engine. If the hoist mechanism fails, the engine will fall on you, causing death or serious injury. • Failure to comply will result in death or serious injury.
0000008en

⚠ DANGER**FIRE AND EXPLOSION HAZARD!**

- Diesel fuel is flammable and explosive under certain conditions.
- When you remove any fuel system component to perform maintenance (such as changing the fuel filter) place an approved container under the opening to catch the fuel.
- NEVER use a shop rag to catch the fuel. Vapors from the rag are flammable and explosive.
- Wipe up any spills immediately.
- Wear eye protection. The fuel system is under pressure and fuel could spray out when you remove any fuel system component.
- Failure to comply will result in death or serious injury.

000009en

⚠ DANGER**FIRE AND EXPLOSION HAZARD!**

- Diesel fuel is flammable and explosive under certain conditions.
- Place an approved container under the air bleed port when you prime the fuel system. Never use a shop rag to catch the fuel. Wipe up any spills immediately. ALWAYS close the air bleed port after you complete priming the system.
- Wear eye protection. The fuel system is under pressure and fuel could spray out when you open the air bleed port.
- If the unit has an electric fuel pump, turn the key switch to the ON position for 10 to 15 seconds, or until the fuel coming out of the air bleed port is free of bubbles, to allow the electric fuel pump to prime the system.
- If the unit has a mechanical fuel pump, operate the fuel priming pump several times until the fuel coming out of the air bleed port is free of bubbles.
- Failure to comply will result in death or serious injury.

000006en

⚠ WARNING**EXHAUST HAZARD!**

- **NEVER** operate the engine in an enclosed area such as a garage, tunnel, underground room, manhole or ship's hold without proper ventilation.
- **NEVER** block windows, vents, or other means of ventilation if the engine is operating in an enclosed area. All internal combustion engines create carbon monoxide gas during operation. Accumulation of this gas within an enclosure could cause illness or even death.
- Make sure that all connections are tightened to specifications after repair is made to the exhaust system.
- Failure to comply could result in death or serious injury.

0000003en

⚠ WARNING**SEVER HAZARD!**

- Keep hands and other body parts away from moving / rotating parts such as the cooling fan, flywheel or PTO shaft.
- Wear tight-fitting clothing and keep your hair short or tie it back while the engine is running.
- Remove all jewelry before you operate or service the machine.
- **NEVER** start the engine in gear. Sudden movement of the engine and / or machine could cause death or serious personal injury.
- **NEVER** operate the engine without the guards in place.
- Before you start the engine make sure that all bystanders are clear of the area.
- Keep children and pets away while the engine is operating.
- Check before starting the engine that any tools or shop rags used during maintenance have been removed from the area.
- Failure to comply could result in death or serious injury.

0000002en

⚠ WARNING



BURN HAZARD!

- Keep your hands and other body parts away from hot engine surfaces such as the muffler, exhaust pipe, turbocharger (if equipped) and engine block during operation and shortly after you shut the engine down. These surfaces are extremely hot while the engine is operating and could seriously burn you.
- Failure to comply could result in death or serious injury.

0000015en

⚠ WARNING



ALCOHOL AND DRUG HAZARD!

- NEVER operate the engine while you are under the influence of alcohol or drugs.
- NEVER operate the engine when you are feeling ill.
- Failure to comply could result in death or serious injury.

0000004en

⚠ WARNING

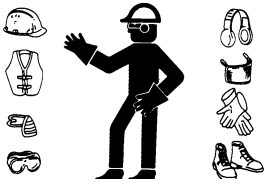

EXPOSURE HAZARD!

- Wear personal protective equipment such as gloves, work shoes, eye and hearing protection as required by the task at hand.
- NEVER wear jewelry, unbuttoned cuffs, ties or loose-fitting clothing when you are working near moving / rotating parts such as the cooling fan, flywheel or PTO shaft.
- ALWAYS tie back long hair when you are working near moving / rotating parts such as a cooling fan, flywheel, or PTO shaft.
- NEVER operate the engine while wearing a headset to listen to music or radio because it will be difficult to hear the alert signals.
- Failure to comply could result in death or serious injury.

0000005en

! WARNING**BURN HAZARD!**

- Batteries contain sulfuric acid. NEVER allow battery fluid to come in contact with clothing, skin or eyes. Severe burns could result. ALWAYS wear safety goggles and protective clothing when servicing the battery. If battery fluid contacts the eyes and / or skin, immediately flush the affected area with a large amount of clean water and obtain prompt medical treatment.
- Failure to comply could result in death or serious injury.

000007en

! WARNING**SHOCK HAZARD!**

- Turn off the battery switch (if equipped) or disconnect the negative battery cable before servicing the electrical system.
- Check the electrical harnesses for cracks, abrasions, and damaged or corroded connectors. ALWAYS keep the connectors and terminals clean.
- Failure to comply could result in death or serious injury.

000009en

! WARNING**HIGH-PRESSURE HAZARD!**

- Avoid skin contact with the high-pressure diesel fuel spray caused by a fuel system leak such as a broken fuel injection line. High-pressure fuel can penetrate your skin and result in serious injury. If you are exposed to high-pressure fuel spray, obtain prompt medical treatment.
- NEVER check for a fuel leak with your hands. ALWAYS use a piece of wood or cardboard. Have your authorized Yanmar industrial engine dealer or distributor repair the damage.
- Failure to comply could result in death or serious injury.

000008en

! WARNING**ENTANGLEMENT HAZARD!**

- Stop the engine before you begin to service it.
- NEVER leave the key in the key switch when you are servicing the engine. Someone may accidentally start the engine and not realize you are servicing it. This could result in a serious injury.
- If you must service the engine while it is operating, remove all jewelry, tie back long hair, and keep your hands, other body parts and clothing away from moving / rotating parts.
- Failure to comply could result in death or serious injury.

000010en

⚠ WARNING



BURN HAZARD!

- If you must drain the engine oil while it is still hot, stay clear of the hot engine oil to avoid being burned.
- **ALWAYS** wear eye protection.
- Failure to comply could result in death or serious injury.

0000011en

⚠ CAUTION



COOLANT HAZARD!

- Wear eye protection and rubber gloves when you handle long life or extended life engine coolant. If contact with the eyes or skin should occur, flush eyes and wash immediately with clean water.
- Failure to comply may result in minor or moderate injury.

0000005en

⚠ CAUTION



FLYING OBJECT HAZARD!

- **ALWAYS** wear eye protection when servicing the engine and when using compressed air or high-pressure water. Dust, flying debris, compressed air, pressurized water or steam may injure your eyes.
- Failure to comply may result in minor or moderate injury.

0000003en

CAUTION

- Only use the engine oil specified. Other engine oils may affect warranty coverage, cause internal engine components to seize and / or shorten engine life.
- Prevent dirt and debris from contaminating the engine oil. Carefully clean the oil cap / dipstick and the surrounding area before you remove the cap.
- **NEVER** mix different types of engine oil. This may adversely affect the lubricating properties of the engine oil.
- **NEVER** overfill. Overfilling may result in white exhaust smoke, engine overspeed or internal damage.

0000005en

CAUTION

- Only use diesel fuels recommended by Yanmar for the best engine performance, to prevent engine damage and to comply with EPA / ARB warranty requirements.
- Only use clean diesel fuel.
- NEVER remove the primary strainer (if equipped) from the fuel tank filler port. If removed, dirt and debris could get into the fuel system causing it to clog.

000004en

CAUTION

- Only use the engine oil specified. Other engine oils may affect warranty coverage, cause internal engine components to seize and / or shorten engine life.
- Prevent dirt and debris from contaminating the engine oil. Carefully clean the oil cap / dipstick and the surrounding area before you remove the cap.
- NEVER mix different types of engine oil. This may adversely affect the lubricating properties of the engine oil.
- NEVER overfill. Overfilling may result in white exhaust smoke, engine overspeed or internal damage.

000005en

CAUTION

- Only use the engine coolant specified. Other engine coolants may affect warranty coverage, cause an internal buildup of rust and scale and / or shorten engine life.
- Prevent dirt and debris from contaminating the engine coolant. Carefully clean the radiator cap and the surrounding area before you remove the cap.
- NEVER mix different types of engine coolants. This may adversely affect the properties of the engine coolant.

000006en

CAUTION

- NEVER attempt to modify the engine's design or safety features such as defeating the engine speed limit control or the diesel fuel injection quantity control.
- Modifications may impair the engine's safety and performance characteristics and shorten the engine's life. Any alterations to this engine may void its warranty. Be sure to use Yanmar genuine replacement parts.

0000079en

CAUTION

Observe the following environmental operating conditions to maintain engine performance and avoid premature engine wear:

- Avoid operating in extremely dusty conditions.
- Avoid operating in the presence of chemical gases or fumes.
- Avoid operating in a corrosive atmosphere such as salt water spray.
- NEVER install the engine in a floodplain unless proper precautions are taken to avoid being subject to a flood.
- NEVER expose the engine to the rain.

000003en

CAUTION

Observe the following environmental operating conditions to maintain engine performance and avoid premature engine wear:

- The standard range of ambient temperatures for the normal operation of Yanmar engines is from +5°F (-15°C) to +113°F (+45°C).
- If the ambient temperature exceeds +113°F (+45°C) the engine may overheat and cause the engine oil to break down.
- If the ambient temperature is below +5°F (-15°C) the engine will be hard to start and the engine oil may not flow easily.
- Contact your authorized Yanmar industrial engine dealer or distributor if the engine will be operated outside of this standard temperature range.

0000065en

CAUTION

NEVER hold the key in the START position for longer than 15 seconds or the starter motor will overheat.

000007en

CAUTION

For maximum engine life, Yanmar recommends that when shutting the engine down, you allow the engine to idle, without load, for five minutes. This will allow the engine components that operate at high temperatures, such as the turbocharger (if equipped) and exhaust system, to cool slightly before the engine itself is shut down.

000008en

CAUTION

NEVER use an engine starting aid such as ether. Engine damage will result.

000009en

CAUTION

Make sure the engine is installed on a level surface. If a continuously running engine is installed at an angle greater than (IDI = 25°, DI = 30°) in any direction or if an engine runs for short periods of time (less than three minutes) at an angle greater than (IDI = 30°, DI = 35°) in any direction, engine oil may enter the combustion chamber causing excessive engine speed and white exhaust smoke. This may cause serious engine damage.

000010enTNV

CAUTION**New Engine Break-in:**

- On the initial engine start-up, allow the engine to idle for approximately 15 minutes while you check for proper engine oil pressure, diesel fuel leaks, engine oil leaks, coolant leaks, and for proper operation of the indicators and / or gauges.
- During the first hour of operation, vary the engine speed and the load on the engine. Short periods of maximum engine speed and load are desirable. Avoid prolonged operation at minimum or maximum engine speeds and loads for the next four to five hours.
- During the break-in period, carefully observe the engine oil pressure and engine temperature.
- During the break-in period, check the engine oil and coolant levels frequently.

0000011en

CAUTION

NEVER engage the starter motor while the engine is running. This may damage the starter motor pinion and / or ring gear.

0000012en

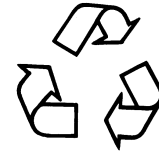
CAUTION

- **ALWAYS** be environmentally responsible.
- Follow the guidelines of the EPA or other governmental agencies for the proper disposal of hazardous materials such as engine oil, diesel fuel and engine coolant. Consult the local authorities or reclamation facility.
- **NEVER** dispose of hazardous materials irresponsibly by dumping them into a sewer, on the ground, or into ground water or waterways.
- Failure to follow these procedures may seriously harm the environment.

0000013en

CAUTION

Protect the air cleaner, turbocharger (if equipped) and electric components from damage when you use steam or high-pressure water to clean the engine.

0000014en

CAUTION

- **NEVER** overfill the engine with engine oil.
- **ALWAYS** keep the oil level between the upper and lower lines on the oil cap / dipstick.

0000015en

CAUTION

NEVER use high-pressure water or compressed air at greater than 28 psi (193 kPa; 19 686 mmAq) or a wire brush to clean the radiator fins. Radiator fins damage easily.

0000016en

CAUTION

NEVER attempt to adjust the low or high idle speed limit screw. This may impair the safety and performance of the machine and shorten its life. If the idle speed limit screws require adjustment, see your authorized Yanmar industrial engine dealer or distributor.

0000017en

CAUTION

Establish a periodic maintenance plan according to the engine application and make sure you perform the required periodic maintenance at intervals indicated. Failure to follow these guidelines will impair the engine's safety and performance characteristics, shorten the engine's life and may affect the warranty coverage on your engine. *See Yanmar Warranties section.*

Consult your authorized Yanmar dealer or distributor for assistance when checking items marked with a ●.

0000024enTNVIDISM

CAUTION

If the fuel filter / water separator is positioned higher than the fuel level in the fuel tank, water may not drip out when the fuel filter / water separator drain cock is opened. If this happens, turn the air vent screw on the top of the fuel filter / water separator 2-3 turns counterclockwise.

Be sure to tighten the air vent screw after the water has drained out.

0000025en

CAUTION

- When the engine is operated in dusty conditions, clean the air cleaner element more frequently.
- NEVER operate the engine with the air cleaner element(s) removed. This may allow foreign material to enter the engine and damage it.

0000026en

CAUTION

The maximum air intake restriction, in terms of differential pressure measurement, must not exceed 0.90 psi (6.23 kPa; 635 mmAq). Clean or replace the air cleaner element if the air intake restriction exceeds the above mentioned value.

0000046en

CAUTION

The tightening torque in the *Standard Torque Chart in General Service Information* should be applied only to the bolts with a “7” head. (JIS strength classification: 7T)

- Apply 60% torque to bolts that are not listed.
- Apply 80% torque when tightened to aluminum alloy.



0000023enTNVIDISM

CAUTION

It is important to perform daily checks.

Periodic maintenance prevents unexpected downtime, reduces the number of accidents due to poor machine performance and helps extend the life of the engine.

0000060en

PRECAUTIONS**The Importance of Periodic Maintenance**

Engine deterioration and wear occurs in proportion to length of time the engine has been in service and the conditions the engine is subject to during operation. Periodic maintenance prevents unexpected downtime, reduces the number of accidents due to poor machine performance and helps extend the life of the engine.

Performing Periodic Maintenance**⚠ WARNING****EXHAUST HAZARD!**

- **NEVER** operate the engine in an enclosed area such as a garage, tunnel, underground room, manhole or ship's hold without proper ventilation.
- **NEVER** block windows, vents, or other means of ventilation if the engine is operating in an enclosed area. All internal combustion engines create carbon monoxide gas during operation. Accumulation of this gas within an enclosure could cause illness or even death.
- **Make sure that all connections are tightened to specifications after repair is made to the exhaust system.**
- **Failure to comply could result in death or serious injury.**

0000003en

Perform periodic maintenance procedures in an open, level area free from traffic. If possible, perform the procedures indoors to prevent environmental conditions, such as rain, wind, or snow, from damaging the machine.

Yanmar Replacement Parts

Yanmar recommends that you use genuine Yanmar parts when replacement parts are needed. Genuine replacement parts help ensure long engine life.

Required EPA / ARB Maintenance - USA Only

To maintain optimum engine performance and compliance with the Environmental Protection Agency (EPA) Regulations Non-road Engines and the California Air Resources Board (ARB, California), it is essential that you follow the *Periodic Maintenance Schedule on page 5-16* and *Periodic Maintenance Procedures on page 5-18*.

EPA / ARB Installation Requirements - USA Only

The following are the installation requirements for the EPA / ARB. Unless these requirements are met, the exhaust gas emissions will not be within the limits specified by the EPA and ARB.

Maximum Exhaust Gas Restriction shall be:

- 2TNV70: 0.85 psi (5.88 kPa; 600 mm Aq) or less
- 3TNV70 and 3TNV76: 1.70 psi (11.76 kPa; 1200 mm Aq) or less

Maximum air intake restriction shall be 0.90 psi (6.23kPa; 635mm Aq) or less. Clean or replace the air cleaner element if the air intake restriction exceeds the above mentioned value.

PERIODIC MAINTENANCE SCHEDULE

Daily and periodic maintenance is important to keep the engine in good operating condition. The following is a summary of maintenance items by periodic maintenance intervals. Periodic maintenance intervals vary depending on engine application, loads, diesel fuel and engine oil used and are hard to establish definitively. The following should be treated only as a general guideline.

CAUTION
<p>Establish a periodic maintenance plan according to the engine application and make sure you perform the required periodic maintenance at intervals indicated. Failure to follow these guidelines will impair the engine's safety and performance characteristics, shorten the engine's life and may affect the warranty coverage on your engine. See Yanmar Warranties section.</p> <p>Consult your authorized Yanmar dealer or distributor for assistance when checking items marked with a ●.</p> <p style="text-align: right; font-size: small;">0000024enTNVIDISM</p>

○:Check ◇:Replace ●: Contact your authorized Yanmar industrial engine dealer or distributor

System	Check Item	Daily	Periodic Maintenance Interval					
			Every 50 hours	Every 250 hours	Every 500 hours	Every 1000 hours	Every 1500 hours	Every 2000 hours
Cooling System	Check and Refill Engine Coolant	○						
	Check and Clean Radiator Fins			○				
	Check and Adjust Cooling Fan V-Belt		○1st time	○2nd and after				
	Drain, Flush and Refill Cooling System with New Coolant					◇ or every 1 yr. whichever comes first		
Cylinder Head	Adjust Intake / Exhaust Valve Clearance					●		
	Lap Intake / Exhaust Valve Seats (if required)							●
Electrical Equipment	Check Indicators	○						
	Check Battery		○					
Engine Oil	Check Engine Oil Level	○						
	Drain and Fill Engine Oil		◇1st time	◇2nd and after				
	Replace Engine Oil Filter							
Engine Speed Control	Check and Adjust Governor Lever and Engine Speed Control	○		○				
Emission Control Warranty	Inspect, Clean and Test Fuel Injectors, if necessary						●	
	Inspect Crankcase Breather System						●	
Fuel	Check and Refill Fuel Tank Level	○						
	Drain Fuel Tank			○				
	Drain Fuel Filter / Water Separator		○					
	Check Fuel Filter / Water Separator	○						
	Clean Fuel Filter / Water Separator				○			
	Replace Fuel Filter				◇			
Hoses	Replace Fuel System and Cooling System Hoses							● or every 2 yrs.
Intake and Exhaust	Clean or Replace Air Cleaner Element			○	◇			
Complete Engine	Overall Visual Check Daily	○						

Note: These procedures are considered normal maintenance and are performed at the owner's expense.

PERIODIC MAINTENANCE PROCEDURES

After Initial 50 Hours of Operation

Perform the following maintenance after the initial 50 hours of operation.

- Replace Engine Oil and Engine Oil Filter
- Check and Adjust Cooling Fan V-Belt

Replace Engine Oil and Engine Oil Filter

⚠ WARNING

<p style="text-align: center;">BURN HAZARD!</p> <ul style="list-style-type: none"> • If you must drain the engine oil while it is still hot, stay clear of the hot engine oil to avoid being burned. • ALWAYS wear eye protection. • Failure to comply could result in death or serious injury. <p style="text-align: right;"><small>0000011en</small></p>

CAUTION
<ul style="list-style-type: none"> • Only use the engine oil specified. Other engine oils may affect warranty coverage, cause internal engine components to seize and / or shorten engine life. • Prevent dirt and debris from contaminating the engine oil. Carefully clean the oil cap / dipstick and the surrounding area before you remove the cap. • NEVER mix different types of engine oil. This may adversely affect the lubricating properties of the engine oil. • NEVER overfill. Overfilling may result in white exhaust smoke, engine overspeed or internal damage. <p style="text-align: right;"><small>0000005en</small></p>

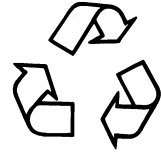
CAUTION

<ul style="list-style-type: none"> • ALWAYS be environmentally responsible. • Follow the guidelines of the EPA or other governmental agencies for the proper disposal of hazardous materials such as engine oil, diesel fuel and engine coolant. Consult the local authorities or reclamation facility. • NEVER dispose of hazardous materials irresponsibly by dumping them into a sewer, on the ground, or into ground water or waterways. • Failure to follow these procedures may seriously harm the environment. <p style="text-align: right;"><small>0000013en</small></p>

The engine oil on a new engine becomes contaminated from the initial break-in of internal parts. It is very important that the initial oil and filter change is performed as scheduled.

Note: The oil drain plug may be in another location if an optional oil pan is used.

Drain the engine oil as follows:

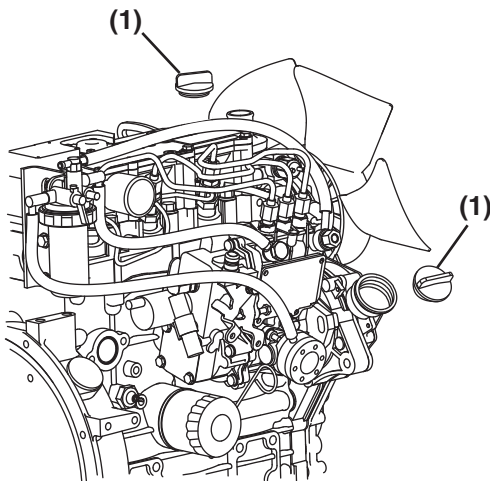
1. Make sure the engine is level.
2. Start the engine and bring it up to operating temperature.
3. Stop the engine.
4. Remove the oil filler cap (**Figure 5-1, (1)**) to vent the engine crankcase and allow the engine oil to drain more easily.
5. Position a container under the engine to collect waste oil.



0000587B

Figure 5-1

6. Remove the oil drain plug (**Figure 5-2, (1)**). Allow oil to drain.
7. After all oil has been drained from the engine, reinstall the oil drain plug (**Figure 5-2, (1)**) and tighten to 39.8 - 47.0 ft·lb (53.9 - 63.7 N·m, 5.5 - 6.5 kgf·m).
8. Dispose of used oil properly.

Remove the engine oil filter as follows:

1. Turn the engine oil filter (**Figure 5-2, (2)**) counterclockwise (**Figure 5-2, (4)**) using a filter wrench.

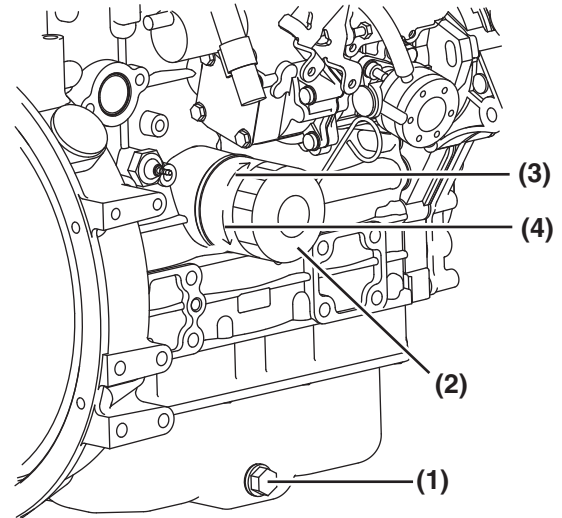

0000651B

Figure 5-2

2. Clean the engine oil filter mounting face.
3. Lightly coat the gasket on the new oil filter with clean engine oil. Install the new engine oil filter manually by turning it clockwise (**Figure 5-2, (3)**) until it contacts the mounting surface. Tighten to 14 - 17 ft·lb (19.6 - 23.5 N·m, 2.0 - 2.4 kgf·m or one additional turn using the filter wrench.

Applicable Engine Oil Filter Part No.	
2TNV70	119305-35150
3TNV70	
3TNV76	

4. Add new engine oil to the engine as specified in *Adding Engine Oil on page 4-14*.

Check and Adjust Cooling Fan V-Belt

The V-belt will slip if it does not have the proper tension. This will prevent the alternator from generating sufficient power. Also, the engine will overheat due to the engine coolant pump pulley slipping.

Check and adjust the V-belt tension (deflection) as follows:

1. Press the V-belt down with your thumb with a force of approximately 22 ft·lb (98 N·m, 10 kgf·m) to check the deflection.

There are three positions to check for V-belt tension (**Figure 5-4, (A), (B) and (C)**). You can check the tension at whichever position is the most accessible. The proper deflection of a used V-belt at each position is:

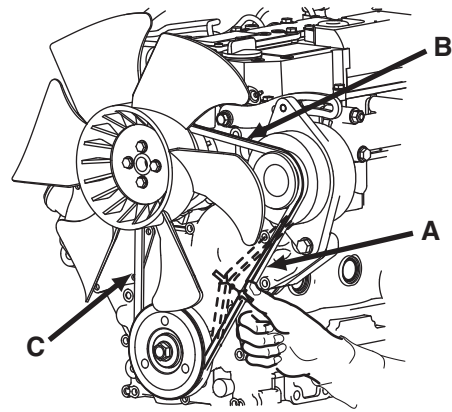

0000652B

Figure 5-4

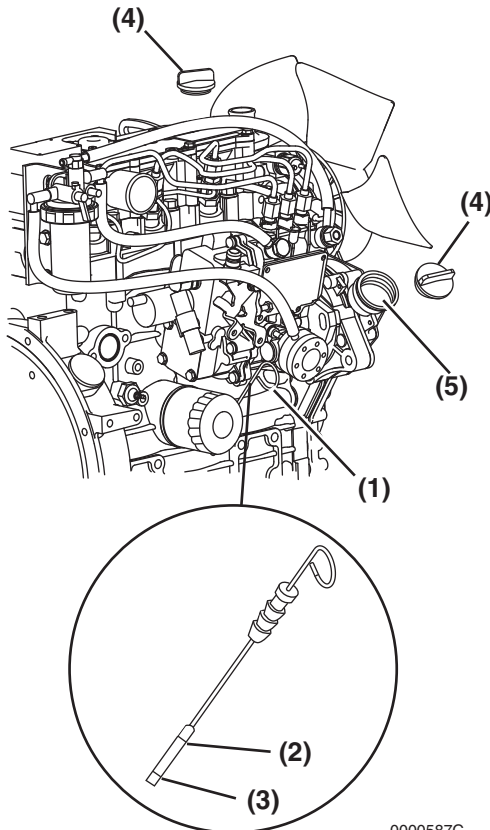

0000587C

Figure 5-3

Used V-Belt Tension		
A	B	C
3/8 - 1/2 in. (10 - 14 mm)	1/4 - 3/8 in. (7 - 10 mm)	5/16 - 1/2 in. (9 - 13 mm)

2. If necessary, adjust the V-belt tension. Loosen the adjusting bolt (**Figure 5-5, (1)**) and move the alternator (**Figure 5-5, (2)**) with a pry bar (**Figure 5-5, (3)**) to tighten the V-belt to the desired tension. Then tighten the adjusting bolt.

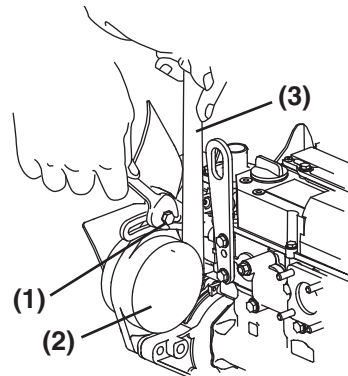

0000653B

Figure 5-5

- Tighten the V-belt to the proper tension. There must be clearance (**Figure 5-6, (1)**) between the V-belt and the bottom of the pulley groove. If there is no clearance (**Figure 5-6, (2)**) between the V-belt and the bottom of the pulley groove, replace the V-belt.

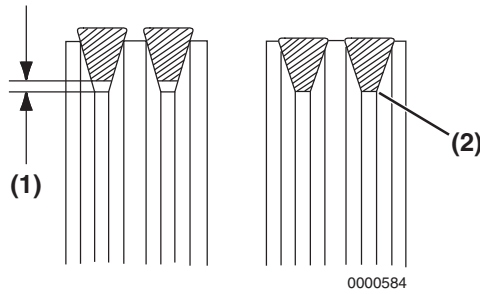

Figure 5-6

- Check the V-belt for cracks, oil or wear. If any of these conditions exist, replace the V-belt.
 - “New V-belt” refers to a V-belt which has been used less than 5 minutes on a running engine.
 - “Used V-belt” refers to a V-belt which has been used on a running engine for 5 minutes or more.
- Inspect the condition of the used V-belt. There must be clearance (**Figure 5-6, (1)**) between the V-belt and the bottom of the pulley groove. If there is no clearance (**Figure 5-6, (2)**) between the V-belt and the bottom of the pulley groove, replace the V-belt.
- Install the new V-belt. Refer to the table for proper tension.

New V-Belt Tension		
A	B	C
5/16 - 7/16 in. (8 - 12 mm)	3/16 - 5/16 in. (5 - 8 mm)	1/4 - 7/16 in. (7 - 11 mm)

- After adjusting, run the engine for 5 minutes or more. Check the tension again using the specifications for a used V-belt.

Used V-Belt Tension		
A	B	C
3/8 - 1/2 in. (10 - 14 mm)	1/4 - 3/8 in. (7 - 10 mm)	5/16 - 1/2 in. (9 - 13 mm)

Every 50 Hours of Operation

After you complete the initial 50 hour maintenance procedures, perform the following procedures every 50 hours thereafter.

- Drain Fuel Filter / Water Separator
- Check Battery

Drain Fuel Filter / Water Separator

⚠ DANGER

FIRE AND EXPLOSION HAZARD!

- Diesel fuel is flammable and explosive under certain conditions.
- When you remove any fuel system component to perform maintenance (such as changing the fuel filter) place an approved container under the opening to catch the fuel.
- NEVER use a shop rag to catch the fuel. Vapors from the rag are flammable and explosive.
- Wipe up any spills immediately.
- Wear eye protection. The fuel system is under pressure and fuel could spray out when you remove any fuel system component.
- Failure to comply will result in death or serious injury.

000009en

CAUTION

If the fuel filter / water separator is positioned higher than the fuel level in the fuel tank, water may not drip out when the fuel filter / water separator drain cock is opened. If this happens, turn the air vent screw on the top of the fuel filter / water separator 2-3 turns counterclockwise.

Be sure to tighten the air vent screw after the water has drained out.

0000025en

CAUTION

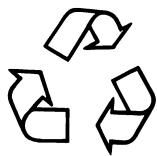

- ALWAYS be environmentally responsible.
- Follow the guidelines of the EPA or other governmental agencies for the proper disposal of hazardous materials such as engine oil, diesel fuel and engine coolant. Consult the local authorities or reclamation facility.
- NEVER dispose of hazardous materials irresponsibly by dumping them into a sewer, on the ground, or into ground water or waterways.
- Failure to follow these procedures may seriously harm the environment.

0000013en

Drain the fuel filter / water separator whenever there are contaminants, such as water, collected in the bottom of the cup. NEVER wait until the scheduled periodic maintenance if contaminants are discovered.

The cup of the separator is made from semi-transparent material. In the cup is a red-colored float ring. The float ring will rise to the surface of the water to show how much needs to be drained. Also, some optional fuel filter / water separators are equipped with a sensor to detect the amount of contaminants. This sensor sends a signal to an indicator to alert the operator.

Drain the fuel filter / water separator as follows:

1. Position an approved container under the fuel filter / water separator (**Figure 5-7, (1)**) to collect the contaminants.

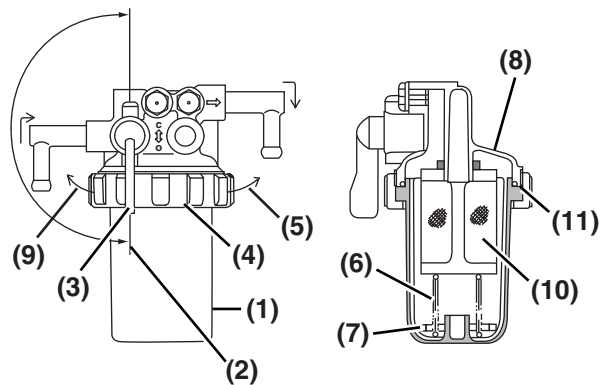

0000590A

Figure 5-7

2. Close (**Figure 5-7, (2)**) the fuel cock (**Figure 5-7, (3)**).
3. Turn the retaining ring (**Figure 5-7, (4)**) to the left (**Figure 5-7, (9)**).
4. Carefully remove the cup (**Figure 5-7, (1)**). Remove the retaining spring (**Figure 5-7, (6)**) and float (**Figure 5-7, (7)**) from the cup. Pour the fuel into an approved container and dispose properly. Hold the bottom of the cup with a shop towel to prevent the fuel from dripping. Wipe up any spills immediately.
5. Clean the inside of the cup.
6. Inspect the condition of the mesh filter (**Figure 5-7, (10)**). Clean the mesh filter if necessary.
7. Inspect the condition of the O-ring (**Figure 5-7, (11)**). Replace the O-ring if necessary.

8. Put the float (**Figure 5-7, (7)**) and retaining spring (**Figure 5-7, (6)**) inside the cup.
9. Reinstall the cup to the mounting flange (**Figure 5-7, (8)**) and turn the retaining ring (**Figure 5-7, (4)**) to the right (**Figure 5-7, (5)**). Hand-tighten only.
10. Open the fuel cock (**Figure 5-7, (3)**).
11. Be sure to prime the fuel system. *See Priming the Fuel System on page 4-12.*
12. Check for fuel leaks.

CAUTION
<p>If the fuel filter / water separator is positioned higher than the fuel level in the fuel tank, water may not drip out when the fuel filter / water separator drain cock is opened. If this happens, turn the air vent screw on the top of the fuel filter / water separator 2-3 turns counterclockwise.</p> <p>Be sure to tighten the air vent screw after the water has drained out.</p> <p style="text-align: right; font-size: small;">0000025en</p>

Check Battery

⚠ DANGER

<p style="text-align: center;">EXPLOSION HAZARD!</p> <ul style="list-style-type: none"> • NEVER check the remaining battery charge by shorting out the terminals. This will result in a spark and may cause an explosion or fire. Use a hydrometer to check the remaining battery charge. • If the electrolyte is frozen, slowly warm the battery before you recharge it. • Failure to comply will result in death or serious injury. <p style="text-align: right; font-size: small;">0000007en</p>

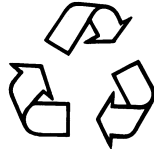
⚠ WARNING

<p style="text-align: center;">BURN HAZARD!</p> <ul style="list-style-type: none"> • Batteries contain sulfuric acid. NEVER allow battery fluid to come in contact with clothing, skin or eyes. Severe burns could result. ALWAYS wear safety goggles and protective clothing when servicing the battery. If battery fluid contacts the eyes and / or skin, immediately flush the affected area with a large amount of clean water and obtain prompt medical treatment. • Failure to comply could result in death or serious injury. <p style="text-align: right; font-size: small;">0000007en</p>

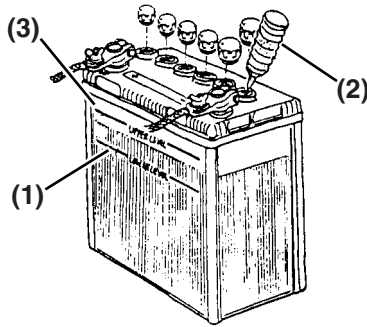
CAUTION

<ul style="list-style-type: none"> • ALWAYS be environmentally responsible. • Follow the guidelines of the EPA or other governmental agencies for the proper disposal of hazardous materials such as engine oil, diesel fuel and engine coolant. Consult the local authorities or reclamation facility. • NEVER dispose of hazardous materials irresponsibly by dumping them into a sewer, on the ground, or into ground water or waterways. • Failure to follow these procedures may seriously harm the environment. <p style="text-align: right; font-size: small;">0000013en</p>

- When the amount of fluid nears the lower limit (**Figure 5-8, (1)**), fill with distilled water (**Figure 5-8, (2)**) so it is at the upper limit (**Figure 5-8, (3)**). If operation continues with insufficient battery fluid, the battery life is shortened, and the battery may overheat and explode. During the summer, check the fluid level more often than specified.



0000067A

Figure 5-8

- If the engine cranking speed is so slow that the engine does not start, recharge the battery.
- If the engine still will not start after charging, have your authorized Yanmar industrial engine dealer or distributor check the battery and the engine's starting system.
- If operating the machine where the ambient temperature could drop to 5°F (-15°C) or less, remove the battery from the machine at the end of the day. Store the battery in a warm place until the next use. This will help start the engine easily at low ambient temperatures.

Every 250 Hours of Operation

Perform the following maintenance every 250 hours of operation.

- Drain Fuel Tank
- Replace Engine Oil and Engine Oil Filter
- Check and Clean Radiator Fins
- Check and Adjust Cooling Fan V-Belt
- Check and Adjust the Governor Lever and Engine Speed Control
- Clean Air Cleaner Element

Drain Fuel Tank

⚠ DANGER



FIRE AND EXPLOSION HAZARD!

- Diesel fuel is flammable and explosive under certain conditions.
- When you remove any fuel system component to perform maintenance (such as changing the fuel filter) place an approved container under the opening to catch the fuel.
- NEVER use a shop rag to catch the fuel. Vapors from the rag are flammable and explosive.
- Wipe up any spills immediately.
- Wear eye protection. The fuel system is under pressure and fuel could spray out when you remove any fuel system component.
- Failure to comply will result in death or serious injury.

0000009en

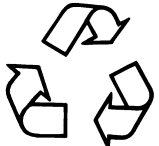
CAUTION

<ul style="list-style-type: none"> • ALWAYS be environmentally responsible. • Follow the guidelines of the EPA or other governmental agencies for the proper disposal of hazardous materials such as engine oil, diesel fuel and engine coolant. Consult the local authorities or reclamation facility. • NEVER dispose of hazardous materials irresponsibly by dumping them into a sewer, on the ground, or into ground water or waterways. • Failure to follow these procedures may seriously harm the environment.
0000013en

4. Drain the tank until clean diesel fuel with no water or dirt flows out. Reinstall and tighten the drain plug firmly.
5. Reinstall the fuel cap.
6. Check for fuel leaks.

Replace Engine Oil and Engine Oil Filter

CAUTION
<ul style="list-style-type: none"> • Only use the engine oil specified. Other engine oils may affect warranty coverage, cause internal engine components to seize and / or shorten engine life. • Prevent dirt and debris from contaminating the engine oil. Carefully clean the oil cap / dipstick and the surrounding area before you remove the cap. • NEVER mix different types of engine oil. This may adversely affect the lubricating properties of the engine oil. • NEVER overfill. Overfilling may result in white exhaust smoke, engine overspeed or internal damage.
0000005en

Note that a typical fuel tank is illustrated.

1. Position an approved container under the diesel fuel tank (**Figure 5-9, (1)**) to collect the contaminates.

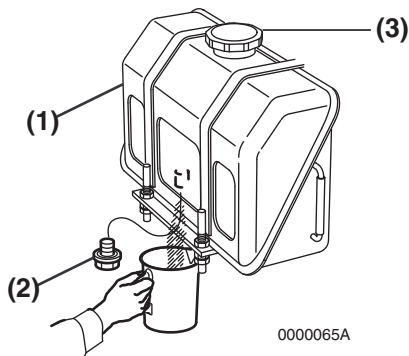
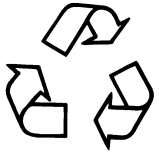



Figure 5-9

2. Remove the fuel cap (**Figure 5-9, (3)**).
3. Remove the drain plug (**Figure 5-9, (2)**) of the fuel tank to drain the contaminates (water, dirt, etc.) from the bottom of the tank.

CAUTION

<ul style="list-style-type: none"> • ALWAYS be environmentally responsible. • Follow the guidelines of the EPA or other governmental agencies for the proper disposal of hazardous materials such as engine oil, diesel fuel and engine coolant. Consult the local authorities or reclamation facility. • NEVER dispose of hazardous materials irresponsibly by dumping them into a sewer, on the ground, or into ground water or waterways. • Failure to follow these procedures may seriously harm the environment.
0000013en

Change the engine oil every 250 hours of operation after the initial change at 50 hours. Replace the engine oil filter at the same time. See *Replace Engine Oil and Engine Oil Filter* on page 5-18.

Check and Clean Radiator Fins

⚠ CAUTION

<p style="text-align: center;">FLYING OBJECT HAZARD!</p> <ul style="list-style-type: none"> • ALWAYS wear eye protection when servicing the engine and when using compressed air or high-pressure water. Dust, flying debris, compressed air, pressurized water or steam may injure your eyes. • Failure to comply may result in minor or moderate injury.
0000003en

Dirt and dust adhering to the radiator fins reduce the cooling performance, causing overheating. Make it a rule to check the radiator fins daily and clean as needed.

Note that a typical radiator is shown in **Figure 5-10** for illustrative purposes only.

- Blow off dirt and dust from fins and radiator with 28 psi (0.19 MPa; 2 kgf/cm²) or less of compressed air (**Figure 5-10, (1)**). Be careful not to damage the fins with the compressed air.
- If there is a large amount of contamination on the fins, apply detergent, thoroughly clean and rinse with tap water.

CAUTION
<p>NEVER use high-pressure water or compressed air at greater than 28 psi (193 kPa; 19 686 mmAq) or a wire brush to clean the radiator fins. Radiator fins damage easily.</p>
0000016en

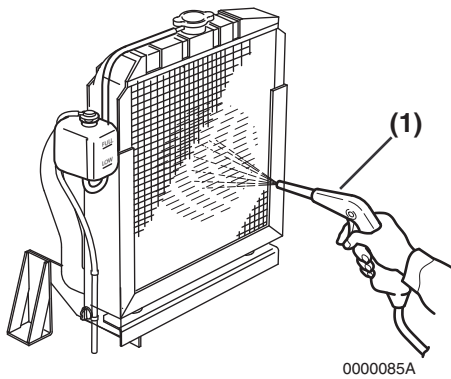

Figure 5-10

Check and Adjust Cooling Fan V-Belt

Check and adjust the cooling fan V-belt every 250 hours of operation after the initial 50 hour V-belt maintenance. See *Check and Adjust Cooling Fan V-Belt* on page 5-19.

Check and Adjust the Governor Lever and Engine Speed Control

The governor lever and engine speed control (throttle lever, accelerator pedal etc.), are connected together by a cable or linkage. If the cable becomes stretched, or the linkage wears or loosens, the governor lever may not respond to a change in the position of the engine speed control.

2. If the governor lever does not make proper contact with the high idle stop or the low idle speed limit screw, adjust the throttle cable or linkage as necessary.

Note: DO NOT FORCE the throttle cable or linkage to move. This may damage the the governor lever, the throttle cable or linkage and cause irregular operation of the engine speed control.

IMPORTANT

The engine speed control (throttle lever, accelerator pedal etc.), should be equipped with stops to prevent the application of excessive pressure by the governor lever to either the high idle stop or low idle speed limit screw.

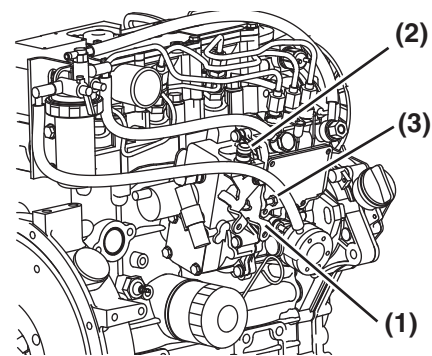

Figure 5-11

CAUTION
<p>NEVER attempt to adjust the low or high idle speed limit screw. This may impair the safety and performance of the machine and shorten its life. If the idle speed limit screws require adjustment, see your authorized Yanmar industrial engine dealer or distributor.</p>
0000017en

1. Check that the governor lever (**Figure 5-11, (1)**) makes firm contact with the high idle stop (**Figure 5-11, (2)**) and the low idle speed limit screw (**Figure 5-11, (3)**) when the engine speed control is in the full speed or low idle speed positions.

Clean Air Cleaner Element

Note that a typical air cleaner is shown in **Figure 5-12** and **Figure 5-13** for illustrative purposes only.

The engine performance is adversely affected when the air cleaner element is clogged with dust. Be sure to clean the air filter element periodically.

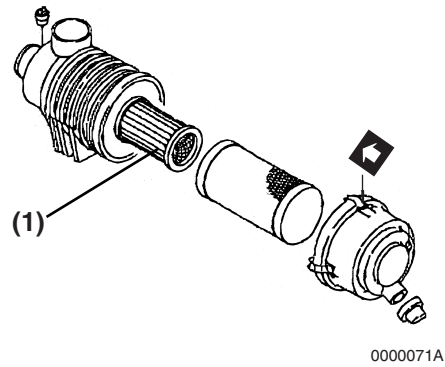

Figure 5-13

CAUTION

- When the engine is operated in dusty conditions, clean the air cleaner element more frequently.
- NEVER operate the engine with the air cleaner element(s) removed. This may allow foreign material to enter the engine and damage it.

0000026en

1. Unlatch and remove the air cleaner cover (**Figure 5-12, (1)**).
2. Remove the element (**Figure 5-12, (2)**) (outer element if equipped with two elements).

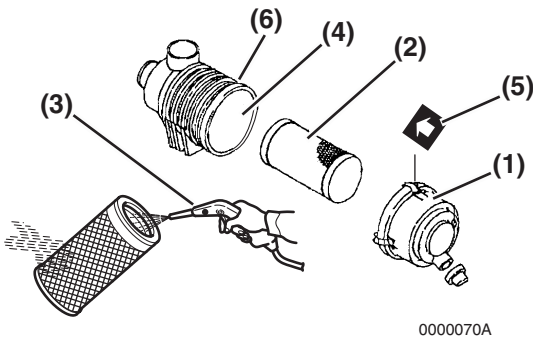

Figure 5-12

CAUTION



FLYING OBJECT HAZARD!

- ALWAYS wear eye protection when servicing the engine and when using compressed air or high-pressure water. Dust, flying debris, compressed air, pressurized water or steam may injure your eyes.
- Failure to comply may result in minor or moderate injury.

0000003en

3. Blow air (**Figure 5-12, (3)**) through the element from the inside out using 42 - 71 psi (0.29 - 0.49 MPa; 3.0 - 5.0 kgf/cm²) compressed air to remove the particulates. Use the lowest possible air pressure to remove the dust without damaging the element.

If the air cleaner is equipped with a double element, only remove and replace the inner element (**Figure 5-13, (1)**) if the engine lacks power or the dust indicator actuates (if equipped).

The inner element should not be removed when cleaning or replacing the outer element. The inner element is used to prevent dust from entering the engine while servicing the outer element.

4. Replace the element with a new one if the element is damaged, excessively dirty or oily.
5. Clean inside of the air cleaner cover.
6. Install the element into the air cleaner case (**Figure 5-12, (4)**).
7. Install the air cleaner cover making sure you match the arrow (**Figure 5-12, (5)**) on the cover with the arrow on the case (**Figure 5-12, (6)**).
8. Latch the air cleaner cover to the case.

Every 500 Hours of Operation

Perform the following maintenance every 500 hours of operation.

- **Replace Air Cleaner Element**
- **Replace Fuel Filter**
- **Clean Fuel Filter / Water Separator**

Replace Air Cleaner Element

CAUTION

The maximum air intake restriction, in terms of differential pressure measurement, must not exceed 0.90 psi (6.23 kPa; 635 mmAq). Clean or replace the air cleaner element if the air intake restriction exceeds the above mentioned value.

0000046en

Replace the air cleaner element (**Figure 5-12, (2)**) every 500 hours even if it is not damaged or dirty.

When replacing the element, clean the inside of the air cleaner case (**Figure 5-12, (4)**).

If the air cleaner is equipped with a double element, only remove and replace the inner element (**Figure 5-13, (1)**) if the engine lacks power or the dust indicator actuates (if equipped). This is in addition to replacing the outer element.

Replace Fuel Filter

⚠ DANGER



FIRE AND EXPLOSION HAZARD!

- Diesel fuel is flammable and explosive under certain conditions.
- When you remove any fuel system component to perform maintenance (such as changing the fuel filter) place an approved container under the opening to catch the fuel.
- NEVER use a shop rag to catch the fuel. Vapors from the rag are flammable and explosive.
- Wipe up any spills immediately.
- Wear eye protection. The fuel system is under pressure and fuel could spray out when you remove any fuel system component.
- Failure to comply will result in death or serious injury.

000009en

CAUTION

For maximum engine life, Yanmar recommends that when shutting the engine down, you allow the engine to idle, without load, for five minutes. This will allow the engine components that operate at high temperatures, such as the turbocharger (if equipped) and exhaust system, to cool slightly before the engine itself is shut down.

000008en

CAUTION

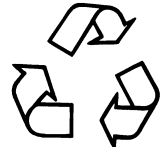

- ALWAYS be environmentally responsible.
- Follow the guidelines of the EPA or other governmental agencies for the proper disposal of hazardous materials such as engine oil, diesel fuel and engine coolant. Consult the local authorities or reclamation facility.
- NEVER dispose of hazardous materials irresponsibly by dumping them into a sewer, on the ground, or into ground water or waterways.
- Failure to follow these procedures may seriously harm the environment.

0000013en

Replace the fuel filter at specified intervals to prevent contaminants from adversely affecting the diesel fuel flow.

1. Stop the engine and allow it to cool.
2. Close the fuel cock of the fuel filter / water separator.
3. Turn the retaining ring (Figure 5-14, (1)) to the left (Figure 5-14, (2)).

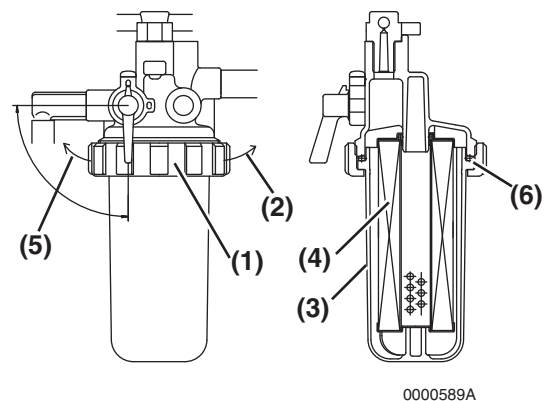

Figure 5-14

4. Carefully remove the cup (**Figure 5-14, (3)**) and pour the fuel into an approved container and dispose of waste properly. Hold the bottom of the cup with a shop towel to prevent the fuel from dripping. Wipe up any spills immediately.
5. Remove the element (**Figure 5-14, (4)**) by pulling it down.
6. Replace the element with a new one.

Applicable Fuel Filter Part No.	
2TNV70	119810-55650
3TNV70	
3TNV76	

7. Wash the inside of the cup with clean fuel.
8. Check the condition of the cup O-ring (**Figure 5-14, (6)**). Replace if necessary.
9. Reinstall the cup to the mounting flange and turn the retaining ring (**Figure 5-14, (1)**) to the right (**Figure 5-14, (2)**). Hand-tighten only.
10. Open the fuel cock of the fuel filter / water separator.
11. Prime the fuel system. *See Priming the Fuel System on page 4-12.*
12. Check for fuel leaks.

Clean Fuel Filter / Water Separator

⚠ DANGER



FIRE AND EXPLOSION HAZARD!

- Diesel fuel is flammable and explosive under certain conditions.
- NEVER** use diesel fuel as a cleaning agent.
- Failure to comply will result in death or serious injury.

0000012en

⚠ DANGER



FIRE AND EXPLOSION HAZARD!

- Diesel fuel is flammable and explosive under certain conditions.
- When you remove any fuel system component to perform maintenance (such as changing the fuel filter) place an approved container under the opening to catch the fuel.
- NEVER** use a shop rag to catch the fuel. Vapors from the rag are flammable and explosive.
- Wipe up any spills immediately.
- Wear eye protection. The fuel system is under pressure and fuel could spray out when you remove any fuel system component.
- Failure to comply will result in death or serious injury.

0000009en

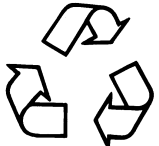
CAUTION

<ul style="list-style-type: none"> • ALWAYS be environmentally responsible. • Follow the guidelines of the EPA or other governmental agencies for the proper disposal of hazardous materials such as engine oil, diesel fuel and engine coolant. Consult the local authorities or reclamation facility. • NEVER dispose of hazardous materials irresponsibly by dumping them into a sewer, on the ground, or into ground water or waterways. • Failure to follow these procedures may seriously harm the environment.
0000013en

Periodically clean the fuel filter / water separator element and inside the cup.

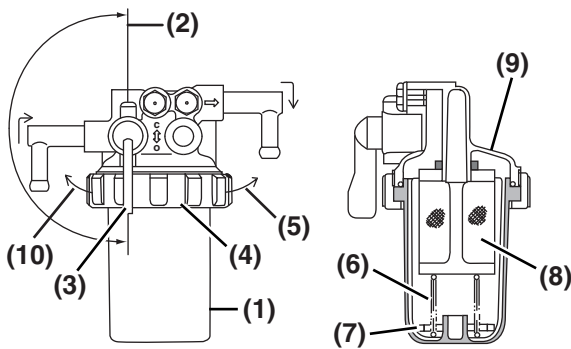
1. Position an approved container under the cup (Figure 5-15, (1)) of the fuel filter / water separator to collect the contaminants.



0000590B

Figure 5-15

2. Close (Figure 5-15, (2)) the fuel cock (Figure 5-15, (3)).

3. Turn the retaining ring (Figure 5-15, (4)) to the left (Figure 5-15, (10)).
4. Carefully remove the cup (Figure 5-15, (1)) and pour the fuel into an approved container and dispose of properly. Hold the bottom of the cup with a shop towel to prevent the fuel from dripping. Wipe up any spills immediately.
5. Keep the retaining spring (Figure 5-15, (6)) and float (Figure 5-15, (7)) handy for reassembly.
6. Remove the element (Figure 5-15, (8)) by pulling it down.
7. Replace the element with a new one.

Applicable Mesh Filter Part No.	
2TNV70	171081-55910
3TNV70	
3TNV76	



8. Wash the inside of the cup with clean diesel fuel.
9. Check the condition of the cup O-ring. Replace if necessary.
10. Put the float (Figure 5-15, (7)) and retaining spring (Figure 5-15, (6)) inside the cup.
11. Reinstall the cup to the mounting flange (Figure 5-15, (9)) and turn the retaining ring (Figure 5-15, (4)) to the right (Figure 5-15, (5)). Hand-tighten only.
12. Open the fuel cock (Figure 5-15, (3)).
13. Prime the fuel system. *See Priming the Fuel System on page 4-12.*
14. Check for fuel leaks.



Every 1000 Hours of Operation

Perform the following maintenance every 1000 hours of operation.

- Drain, Flush and Refill Cooling System with New Coolant
- Adjust Intake / Exhaust Valve Clearance

Drain, Flush and Refill Cooling System with New Coolant

 DANGER

<p style="text-align: center;">SCALD HAZARD!</p> <ul style="list-style-type: none"> • NEVER remove the radiator cap if the engine is hot. Steam and hot engine coolant will spurt out and seriously burn you. Allow the engine to cool down before you attempt to remove the radiator cap. • Tighten the radiator cap securely after you check the radiator. Steam can spurt out during engine operation if the cap is loose. • ALWAYS check the level of the engine coolant by observing the reserve tank. • Failure to comply will result in death or serious injury. <p style="text-align: right; font-size: small;">000002en</p>

 WARNING

<p style="text-align: center;">BURN HAZARD!</p> <ul style="list-style-type: none"> • Wait until the engine cools before you drain the engine coolant. Hot engine coolant may splash and burn you. • Failure to comply could result in death or serious injury. <p style="text-align: right; font-size: small;">0000016en</p>

 CAUTION

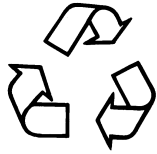
<p style="text-align: center;">COOLANT HAZARD!</p> <ul style="list-style-type: none"> • Wear eye protection and rubber gloves when you handle long life or extended life engine coolant. If contact with the eyes or skin should occur, flush eyes and wash immediately with clean water. • Failure to comply may result in minor or moderate injury. <p style="text-align: right; font-size: small;">0000005en</p>

CAUTION



- **ALWAYS** be environmentally responsible.
- Follow the guidelines of the EPA or other governmental agencies for the proper disposal of hazardous materials such as engine oil, diesel fuel and engine coolant. Consult the local authorities or reclamation facility.
- **NEVER** dispose of hazardous materials irresponsibly by dumping them into a sewer, on the ground, or into ground water or waterways.
- Failure to follow these procedures may seriously harm the environment.

0000013en

Engine coolant contaminated with rust or scale reduces the cooling effect. Even when extended life engine coolant is properly mixed, the engine coolant gets contaminated as its ingredients deteriorate. Drain, flush and refill the cooling system with new coolant every 1000 hours or once a year, whichever comes first.

1. Allow engine and coolant to cool.
2. Remove the radiator cap (**Figure 5-16, (1)**).
3. Remove the drain plug or open the drain cock (**Figure 5-16, (2)**) at the lower position of the radiator and drain the engine coolant.

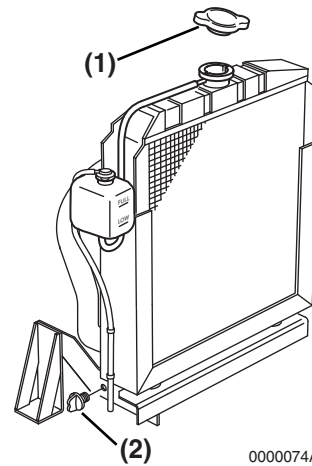

0000074A

Figure 5-16

4. Drain the coolant from the engine block. Remove the coolant drain plug (**Figure 5-17, (1)**) from the engine block.

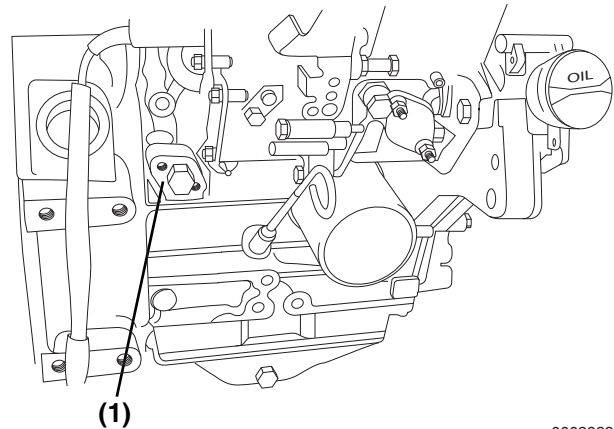

0002923A

Figure 5-17

5. After draining the engine coolant, flush the radiator and engine block to remove any rust, scale and contaminants.
6. Reinstall and tighten the drain plug or close the drain cock at the radiator. Reinstall and tighten the engine block drain plug.
7. Fill radiator and engine with engine coolant. See *Filling Radiator with Engine Coolant* on page 4-16.

Adjust Intake / Exhaust Valve Clearance

Proper adjustment is necessary to maintain the correct timing for opening and closing the valves. Improper adjustment will cause the engine to run noisily, resulting in poor engine performance and engine damage. See *Measuring and Adjusting Valve Clearance* on page 6-34.

Every 1500 Hours of Operation

Perform the following maintenance every 1500 hours of operation.

- **Inspect, Clean and Test Fuel Injectors, if necessary**
- **Inspect Crankcase Breather System**

Inspect, Clean and Test Fuel Injectors

⚠ WARNING

<p style="text-align: center;">HIGH-PRESSURE HAZARD!</p> <ul style="list-style-type: none"> • Avoid skin contact with the high-pressure diesel fuel spray caused by a fuel system leak such as a broken fuel injection line. High-pressure fuel can penetrate your skin and result in serious injury. If you are exposed to high-pressure fuel spray, obtain prompt medical treatment. • NEVER check for a fuel leak with your hands. ALWAYS use a piece of wood or cardboard. Have your authorized Yanmar industrial engine dealer or distributor repair the damage. • Failure to comply could result in death or serious injury. <p style="text-align: right; font-size: small;">000008en</p>

Proper operation of the fuel injectors is required to obtain the optimum injection pattern for full engine performance. The EPA / ARB requires that the fuel injectors are inspected, cleaned and tested every 1500 hours. See *Testing of Fuel Injectors* on page 7-24.

This procedure is considered normal maintenance and is performed at the owner's expense. This procedure is not covered by the Yanmar Limited Warranty.

Inspect Crankcase Breather System

Proper operation of the crankcase breather system is required to maintain the emission requirements of the engine. The EPA / ARB requires that the crankcase breather system is inspected every 1500 hours.

There are three different crankcase breather systems used on the TNV engines. Only the non-turbo TNV engines crankcase breather system requires periodic maintenance.

The non-turbo TNV engines use a crankcase breather system that has a spring-backed diaphragm **(Figure 5-18, (1))** in the valve cover **(Figure 5-18, (2))**. When the crankcase pressure reaches a predetermined value, the diaphragm opens a passage that allows crankcase fumes to be routed to the intake manifold.

2. Remove the diaphragm cover, spring, diaphragm plate **(Figure 5-18, (5))** and diaphragm.
3. Inspect the diaphragm for tears. Inspect the spring for distortion. Replace components if necessary.
4. Reinstall the diaphragm, diaphragm plate, spring and diaphragm cover. Tighten the diaphragm bolts to the specified torque. See *Tightening Torques for Standard Bolts and Nuts on page 4-24*.

Failure of the diaphragm and / or spring will cause the loss of pressure control and allow an excessive amount of crankcase fumes to be routed to the intake manifold. This could result in excessive deposits in the intake system, high engine exhaust smoke levels, excessive engine oil consumption, and / or engine run-on due to the burning of the engine oil.

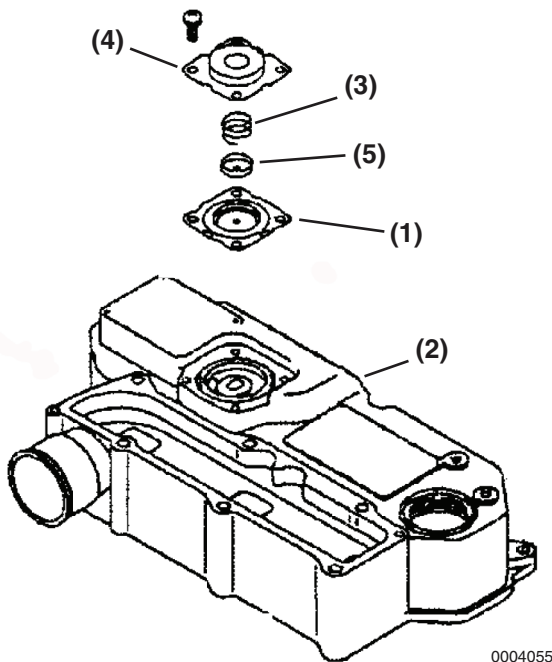

Figure 5-18

To inspect the diaphragm and spring **(Figure 5-18, (3))**:

1. Remove the bolts retaining the diaphragm cover **(Figure 5-18, (4))**.

Every 2000 Hours of Operation

Perform the following maintenance every 2000 hours of operation.

- **Check and Replace Fuel Hoses and Engine Coolant Hoses**
- **Lap the Intake and Exhaust Valves**

Check and Replace Fuel Hoses and Engine Coolant Hoses

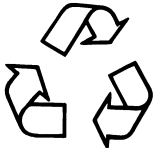
CAUTION

<ul style="list-style-type: none"> • ALWAYS be environmentally responsible. • Follow the guidelines of the EPA or other governmental agencies for the proper disposal of hazardous materials such as engine oil, diesel fuel and engine coolant. Consult the local authorities or reclamation facility. • NEVER dispose of hazardous materials irresponsibly by dumping them into a sewer, on the ground, or into ground water or waterways. • Failure to follow these procedures may seriously harm the environment.
0000013en

Regularly check the fuel system and engine coolant system hoses. If they are cracked or degraded, replace them. Replace the hoses at least every two years. *See Check and Replace Fuel Hoses and Engine Coolant Hoses on page 5-37.*

Lap the Intake and Exhaust Valves

Adjustment is necessary to maintain proper contact of the valves and seats. *See Inspection of Intake and Exhaust Valves on page 6-27.*

This Page Intentionally Left Blank

Section 6

ENGINE

	Page
Before You Begin Servicing	6-3
Introduction.....	6-5
Cylinder Head Specifications	6-5
Adjustment Specifications	6-5
Cylinder Head.....	6-5
Intake / Exhaust Valve and Guide	6-6
Push Rod.....	6-6
Valve Spring	6-6
Rocker Arm and Shaft	6-7
Camshaft and Timing Gear Train Specifications.....	6-7
Camshaft	6-7
Idle Gear Shaft and Bushing	6-8
Timing Gear Backlash	6-8
Crankshaft and Pistons Specifications	6-8
Crankshaft	6-8
Crankshaft Reconditioning	6-9
Thrust Bearing	6-9
Piston.....	6-10
Piston Ring	6-11
Connecting Rod.....	6-12
Tappet	6-13
Cylinder Block Specifications	6-13
Cylinder Block.....	6-13
Special Torque Chart	6-14
Torque for Bolts and Nuts.....	6-14
Special Service Tools.....	6-15
Measuring Instruments.....	6-17

Cylinder Head	6-20
Cylinder Head Components	6-20
Disassembly of Cylinder Head	6-21
Cleaning of Cylinder Head Components	6-25
Inspection of Cylinder Head Components	6-25
Reassembly of Cylinder Head	6-29
Measuring and Adjusting Valve Clearance	6-34
Cylinder Block	6-36
Crankshaft and Camshaft Components	6-36
Disassembly of Cylinder Block Components	6-37
Disassembly of Camshaft and Timing Components	6-38
Disassembly of Crankshaft and Piston Components	6-42
Inspection of Crankshaft and Camshaft Components	6-46
Reconditioning the Crankshaft	6-51
Honing and Boring	6-53
Reassembly of Crankshaft and Piston Components	6-54
Reassembly of Camshaft and Timing Components	6-60

BEFORE YOU BEGIN SERVICING

⚠ WARNING



To prevent possible eye injury, always wear **SAFETY GLASSES** while servicing the engine.

0000013en

⚠ WARNING



ENTANGLEMENT HAZARD!

- Stop the engine before you begin to service it.
- **NEVER** leave the key in the key switch when you are servicing the engine. Someone may accidentally start the engine and not realize you are servicing it. This could result in a serious injury.
- If you must service the engine while it is operating, remove all jewelry, tie back long hair, and keep your hands, other body parts and clothing away from moving / rotating parts.
- Failure to comply could result in death or serious injury.

0000010en

⚠ WARNING



FUME / BURN HAZARD!

- Always read and follow safety related precautions found on containers of hazardous substances like parts cleaners, primers, sealants and sealant removers.
- Failure to comply could result in death or serious injury.

0000014en

⚠ CAUTION



FLYING OBJECT HAZARD!

- **ALWAYS** wear eye protection when servicing the engine and when using compressed air or high-pressure water. Dust, flying debris, compressed air, pressurized water or steam may injure your eyes.
- Failure to comply may result in minor or moderate injury.

0000003en

CAUTION

NEVER use an engine starting aid such as ether. Engine damage will result.

0000009en

CAUTION

- Only use the engine oil specified. Other engine oils may affect warranty coverage, cause internal engine components to seize and / or shorten engine life.
- Prevent dirt and debris from contaminating the engine oil. Carefully clean the oil cap / dipstick and the surrounding area before you remove the cap.
- NEVER mix different types of engine oil. This may adversely affect the lubricating properties of the engine oil.
- NEVER overfill. Overfilling may result in white exhaust smoke, engine overspeed or internal damage.

000005en

CAUTION

Any part which is found defective as a result of inspection or any part whose measured value does not satisfy the standard or limit must be replaced.

0000119en

CAUTION

- Only use the engine coolant specified. Other engine coolants may affect warranty coverage, cause an internal buildup of rust and scale and / or shorten engine life.
- Prevent dirt and debris from contaminating the engine coolant. Carefully clean the radiator cap and the surrounding area before you remove the cap.
- NEVER mix different types of engine coolants. This may adversely affect the properties of the engine coolant.

000006en

CAUTION

Do not loosen or remove the four bolts retaining the fuel injection pump drive gear to the fuel injection pump hub. Do not disassemble the fuel injection pump drive gear from the hub. Correct fuel injection timing will be very difficult or impossible to achieve.

0000031en

CAUTION

Identify all parts and their location using an appropriate method. It is important that all parts are returned to the same position during the reassembly process.

0000080en

CAUTION

Keep the piston pin parts, piston assemblies, and connecting rod assemblies together to be returned to the same position during the reassembly process. Label the parts using an appropriate method.

0000088en

CAUTION

Do not allow the honing tool to operate in one position for any length of time. Damage to the cylinder wall will occur. Keep the tool in constant up-and-down motion.

0000090en

CAUTION

Any part determined to not meet the service standard or limit before the next service, as determined from the state of current rate of wear, should be replaced even though the part currently meets the service standard limit.

0000120en

INTRODUCTION

This section of the *Service Manual* describes servicing of the engine.

CYLINDER HEAD SPECIFICATIONS

Adjustment Specifications

Model	Valve Clearance
All	0.006 - 0.010 in. (0.15 - 0.25 mm)

Cylinder Head

Inspection Item		Standard	Limit	Reference Page
Combustion Surface Distortion (Flatness)		0.0020 in. (0.05 mm) or less	0.0059 in. (0.15 mm)	<i>See Valve Recession on page 6-27</i>
Valve Recession	Intake	0.0157 - 0.0236 in. (0.4 - 0.6 mm)	0.0354 in. (0.9 mm)	
	Exhaust	0.0157 - 0.0236 in. (0.4 - 0.6 mm)	0.0315 in. (0.8 mm)	
Valve Seat	Seat Angle	Intake	120°	<i>See Valve Face and Valve Seat on page 6-28</i>
		Exhaust	90°	
	Seat Correction Angle		40°, 150°	

Intake / Exhaust Valve and Guide

Inspection Item		Standard	Limit	Reference Page
Intake	Guide Inside Diameter	0.2362 - 0.2367 in. (6.000 - 6.012 mm)	0.2394 in. (6.08 mm)	<i>See Inspection of Valve Springs on page 6-28</i>
	Valve Stem Outside Diameter	0.2346 - 0.2352 in. (5.960 - 5.975 mm)	0.2323 in. (5.90 mm)	
	Oil Clearance	0.0010 - 0.0020 in. (0.025 - 0.052 mm)	0.0063 in. (0.15 mm)	
	Valve Stem Bend	-	0.0004 in. (0.010 mm)	
Exhaust	Guide Inside Diameter	0.2362 - 0.2367 in. (6.000 - 6.012 mm)	0.2394 in. (6.08 mm)	
	Valve Stem Outside Diameter	0.2341 - 0.2346 in. (5.945 - 5.960 mm)	0.2323 in. (5.90 mm)	
	Oil Clearance	0.0016 - 0.0026 in. (0.040 - 0.067 mm)	0.0067 in. (0.17 mm)	
	Valve Stem Bend	-	0.0004 in. (0.010 mm)	
Valve Guide Projection From Cylinder Head		0.3858 - 0.3937 in. (9.8 - 10.0 mm)	-	<i>See Reassembly of Valve Guides on page 6-29</i>
Valve Stem Seal Projection From Cylinder Head		0.429 - 0.441 in. (10.9 - 11.2 mm)		
Valve Guide Installation Method		Cold-fitted	-	

Push Rod

Inspection Item	Standard	Limit	Reference Page
Push Rod Bend	Less than 0.0012 in. (0.03 mm)	0.0012 in. (0.03 mm)	<i>See Push Rod Bend on page 6-25</i>

Valve Spring

Inspection Item	Standard	Limit	Reference Page
Free Length	1.4882 in. (37.8 mm)	-	<i>See Inspection of Valve Springs on page 6-28</i>
Squareness	-	0.0512 in. (1.3 mm)	

Rocker Arm and Shaft

Inspection Item	Standard	Limit	Reference Page
Arm Shaft Hole Diameter	0.4724 - 0.4732 in. (12.000 - 12.020 mm)	0.4752 in. (12.07 mm)	<i>See Inspection of Rocker Arm Assembly on page 6-26</i>
Shaft Outside Diameter	0.4711 - 0.4718 in. (11.966 - 11.984 mm)	0.4701 in. (11.94 mm)	
Oil Clearance	0.0006 - 0.0021 in. (0.016 - 0.054 mm)	0.0051 in. (0.13 mm)	

CAMSHAFT AND TIMING GEAR TRAIN SPECIFICATIONS

Camshaft

Inspection Item		Standard	Limit	Reference Page	
End Play		0.0020 - 0.0059 in. (0.05 - 0.15 mm)	0.0098 in. (0.25 mm)	<i>See Removal of Camshaft on page 6-41</i>	
Bend (1/2 the dial gauge reading)		0 - 0.0008 in. (0 - 0.02 mm)	0.0020 in. (0.05 mm)	<i>See Inspection of Camshaft on page 6-52</i>	
Cam Lobe Height		1.3439 - 1.3490 in. (34.135 - 34.265 mm)	1.3343 in. (33.89 mm)		
Shaft Outside Diameter / Bearing Inside Diameter	Gear End	Bushing Inside Diameter	1.5748 - 1.5778 in. (40.000 - 40.075 mm)		1.5807 in. (40.150 mm)
		Camshaft Outside Diameter	1.5724 - 1.5732 in. (39.940 - 39.960 mm)		1.5711 in. (39.905 mm)
		Oil Clearance	0.0016 - 0.0053 in. (0.040 - 0.135 mm)		0.0096 in. (0.245 mm)
	Intermediate	Bushing Inside Diameter	1.5748 - 1.5758 in. (40.000 - 40.025 mm)		1.5787 in. (40.100 mm)
		Camshaft Outside Diameter	1.5713 - 1.5722 in. (39.910 - 39.935 mm)		1.5699 in. (39.875 mm)
		Oil Clearance	0.0026 - 0.0045 in. (0.065 - 0.115 mm)		0.0089 in. (0.225 mm)
	Flywheel End	Bushing Inside Diameter	1.5748 - 1.5758 in. (40.000 - 40.100 mm)		1.5787 in. (40.100 mm)
		Camshaft Outside Diameter	1.5724 - 1.5732 in. (39.940 - 39.960 mm)		1.5711 in. (39.905 mm)
		Oil Clearance	0.0016 - 0.0033 in. (0.040 - 0.085 mm)	0.0077 in. (0.195 mm)	

Idler Gear Shaft and Bushing

Inspection Item	Standard	Limit	Reference Page
Shaft Outside Diameter	1.4547 - 1.4557 in. (36.950 - 36.975 mm)	1.4528 in. (36.900 mm)	<i>See Inspection of Idler Gear and Shaft on page 6-53</i>
Bushing Inside Diameter	1.4567 - 1.4577 in. (37.000 - 37.025 mm)	1.4596 in. (37.075 mm)	
Oil Clearance	0.0010 - 0.0030 in. (0.025 - 0.075 mm)	0.0069 in. (0.175 mm)	

Timing Gear Backlash

Inspection Item	Standard	Limit	Reference Page
Crank Gear, Cam Gear, Idler Gear, Fuel Injection Pump Gear and PTO Gear	0.0024 - 0.0047 in. (0.06 - 0.12 mm)	0.0055 in. (0.14 mm)	<i>See Checking Timing Gear Backlash on page 6-38</i>

CRANKSHAFT AND PISTONS SPECIFICATIONS

Crankshaft

Note: Check appropriate parts catalog for undersized replacement main bearing inserts.

Inspection Item			Standard	Limit	Reference Page
Bend (1/2 the dial gauge reading)			-	0.0008 in. (0.02 mm)	<i>See Inspection of Crankshaft on page 6-51</i>
Roundness			0.0004 in.(0.01 mm) or less	0.0008 in. (0.02 mm)	
Connecting Rod Journals	Journal Outside Diameter	2TNV70	1.4942 - 1.4946 in. (37.952 - 37.962 mm)	1.4725 in. (37.402 mm)	
		3TNV70			
	Bearing Inside Diameter	3TNV76	1.6517 - 1.6520 in. (41.952 - 41.962 mm)	1.6497 in. (41.902 mm)	
		2TNV70	1.4954 - 1.4965 in. (37.982 - 38.010 mm)	-	
	3TNV70				
	Bearing Insert Thickness	3TNV76	1.6528 - 1.6536 in. (41.982 - 42.002 mm)	-	
2TNV70		0.0592 - 0.0594 in. (1.503 - 1.509 mm)	-		
3TNV70					
Oil Clearance	3TNV76	0.0008 - 0.0023 in. (0.020 - 0.058 mm)	0.0043 in. (0.110 mm)		
	2TNV70	0.0008 - 0.0020 in. (0.020 - 0.050 mm)	0.0043 in. (0.110 mm)		

(Crankshaft Cont.)

Inspection Item		Standard	Limit	Reference Page
Main Bearing Journal	Journal Outside Diameter	1.8485 - 1.8489 in. (46.952 - 46.962 mm)	1.8465 in. (46.902 mm)	See <i>Inspection of Crankshaft on page 6-51</i>
	Bearing Inside Diameter	1.8497 - 1.8505 in. (46.982 - 47.002 mm)	-	
	Bearing Insert Thickness	0.0791 - 0.0793 in. (2.009 - 2.014 mm)	-	
	Oil Clearance	0.0008 - 0.0020 in. (0.020 - 0.050 mm)	0.0047 in. (0.120 mm)	

Crankshaft Reconditioning

Item	Finishing Precision	Reference Page
Connecting Rod Journal Undersize Finished Size	1.6418 - 1.6422 in. (41.702 - 41.712 mm)	See <i>Reconditioning the Crankshaft on page 6-51</i>
Main Bearing Journal Undersize Finished Size	1.8387 - 1.8391 in. (46.702 - 46.712 mm)	
Journal Radius	0.138 - 0.150 in. (3.5 - 3.8 mm)	
Journal Face Finish	0.8S (Super Polish)	
Thrust Face Finish	1.6	

Thrust Bearing

Inspection Item	Standard	Limit	Reference Page
Crankshaft End Play - All Models	0.0044 - 0.0098 in. (0.111 - 0.250 mm)	0.0110 in. (0.28 mm)	See Removal of Crankshaft on page 6-44
Bearing Thickness	0.0760 - 0.0780 in. (1.930 - 1.980 mm)	0.0728 in. (1.850 mm)	

Piston

Inspection Item		Standard	Limit	Reference Page
Piston Outside Diameter (Measure at 90° to the Piston Pin.)	2/3TNV70	2.7543 - 2.7555 in. (69.960 - 69.990 mm)	2.7526 in. (69.915 mm)	<i>See Inspection of Pistons, Piston Rings and Wrist Pin on page 6-48</i>
	3TNV76	2.9904 - 2.9915 in. (75.955 - 75.985 mm)	2.9886 in. (75.910 mm)	
Piston Diameter Measurement Location (Upward From the Bottom of the Piston)		0.8661 - 0.9843 in. (22.0 - 25.0 mm)	-	
Piston-to-Cylinder Clearance	2/3TNV70	0.0012 - 0.0020 in. (0.030 - 0.050 mm)	-	
	3TNV76	0.0014 - 0.0022 in. (0.035 - 0.055 mm)	-	
Wrist Pin	Hole Inside Diameter	0.8661 - 0.8665 in. (22.000 - 22.009 mm)	0.8677 in. (220.039 mm)	
	Pin Outside Diameter	0.8659 - 0.8661 in. (21.995 - 22.000 mm)	0.8648 in. (21.965 mm)	
	Oil Clearance	0.0000 - 0.0006 in. (0.000 - 0.014 mm)	0.0029 in. (0.074 mm)	

Piston Ring

Model	Inspection Item		Standard	Limit	Reference Page
2TNV70 3TNV70	Top Ring	Ring Groove Width	0.0610 - 0.0618 in. (1.550 - 1.570 mm)	-	<i>See Inspection of Pistons, Piston Rings and Wrist Pin on page 6-48</i>
		Ring Width	0.0579 - 0.0587 in. (1.470 - 1.490 mm)	0.0571 in. (1.450 mm)	
		Side Clearance	0.0024 - 0.0039 in. (0.060 - 0.100 mm)	-	
		End Clearance	0.0059 - 0.0118 in. (0.150 - 0.300 mm)	0.0154 in. (0.390 mm)	
	Second Ring	Ring Groove Width	0.0606 - 0.0614 in. (1.540 - 1.560 mm)	0.0654 in. (1.660 mm)	
		Ring Width	0.0579 - 0.0587 in. (1.470 - 1.490 mm)	0.0571 in. (1.950 mm)	
		Side Clearance	0.0020 - 0.0035 in. (0.050 - 0.090 mm)	0.0083 in. (0.210 mm)	
		End Clearance	0.0071 - 0.0130 in. (0.180 - 0.33 mm)	0.0165 in. (0.42 mm)	
	Oil Ring	Ring Groove Width	0.1185 - 0.1193 in. (3.010 - 3.030 mm)	0.1232 in. (3.130 mm)	
		Ring Width	0.1170 - 0.1177 in. (2.970 - 2.990 mm)	0.1161 in. (2.950 mm)	
		Side Clearance	0.0008 - 0.0024 in. (0.020 - 0.060 mm)	0.0071 in. (0.180 mm)	
		End Clearance	0.0059 - 0.0138 in. (0.150 - 0.350 mm)	0.0173 in. (0.440 mm)	

(Piston Ring Cont.)

Model	Inspection Item		Standard	Limit	Reference Page
3TNV76	Top Ring	Ring Groove Width	0.0610 - 0.0618 in. (1.550 - 1.570 mm)	-	<i>See Inspection of Pistons, Piston Rings and Wrist Pin on page 6-48</i>
		Ring Width	0.0579 - 0.0587 in. (1.470 - 1.490 mm)	0.0571 in. (1.450 mm)	
		Side Clearance	0.0024 - 0.0039 in. (0.060 - 0.100 mm)	-	
		End Clearance	0.0059 - 0.0118 in. (0.150 - 0.300 mm)	0.0154 in. (0.390 mm)	
	Second Ring	Ring Groove Width	0.0622 - 0.0628 in. (1.580 - 1.595 mm)	0.0667 in. (1.695 mm)	
		Ring Width	0.0563 - 0.0571 in. (1.430 - 1.450 mm)	0.0555 in. (1.410 mm)	
		Side Clearance	0.0005 - 0.0065 in. (0.013 - 0.165 mm)	0.0112 in. (0.285 mm)	
		End Clearance	0.0071 - 0.0130 in. (0.180 - 0.33 mm)	0.0165 in. (0.42 mm)	
	Oil Ring	Ring Groove Width	0.1185 - 0.1193 in. (3.010 - 3.030 mm)	0.1232 in. (3.130 mm)	
		Ring Width	0.1169 - 0.1177 in. (2.970 - 2.990 mm)	0.1161 in. (2.950 mm)	
		Side Clearance	0.0008 - 0.0024 in. (0.020 - 0.060 mm)	0.0071 in. (0.180 mm)	
		End Clearance	0.0079 - 0.0177 in. (0.200 - 0.450 mm)	0.0213 in. (0.540 mm)	

Connecting Rod**Connecting Rod Small End**

Inspection Item	Standard	Limit	Reference Page
Wrist Pin Bushing Inside Diameter	0.8671 - 0.8676 in. (22.025 - 22.038 mm)	0.8688 in. (22.068 mm)	<i>See Inspection of Connecting Rod on page 6-49</i>
Wrist Pin Outside Diameter	0.8658 - 0.8661 in. (21.991 - 22.000 mm)	0.8647 in. (21.963 mm)	
Oil Clearance	0.0010 - 0.0019 in. (0.025 - 0.047 mm)	0.0041 in. (0.105 mm)	

Connecting Rod Big End

Inspection Item	Standard	Limit	Reference Page
Side Clearance	0.0079 - 0.0157 in. (0.20 - 0.40 mm)	-	See <i>Inspection of Connecting Rod on page 6-49</i>
Bearing Inside Diameter and Oil Clearance	See Crankshaft on page 6-8		

Connecting Rod Distortion

Model	Inspection Item	Standard	Limit	Reference Page
All Models	Twist and Bend per 3.937 in.(100 mm)	Less than 0.001 in. (0.03 mm)	0.003 in. (0.08 mm)	See <i>Inspection of Connecting Rod on page 6-49</i>

Tappet

Inspection Item	Standard	Limit	Reference Page
Tappet Bore (Block) Inside Diameter	0.8268 - 0.8276 in. (21.000 - 21.021 mm)	0.8284 in. (21.041 mm)	See <i>Inspection of Tappets on page 6-50</i>
Tappet Stem Outside Diameter	0.8239 - 0.8252 in. (20.927 - 20.960 mm)	0.8231 in. (20.907 mm)	
Oil Clearance	0.0016 - 0.0037 in. (0.040 - 0.094 mm)	0.0053 in. (0.134 mm)	

CYLINDER BLOCK SPECIFICATIONS

Cylinder Block

Inspection Item	Model	Standard	Limit	Reference Page
Cylinder Inside Diameter	2TNV70 3TNV70	2.7563 - 2.7567 in. (70.010 - 70.020 mm)	2.7638 in. (70.200 mm)	See <i>Inspection of Cylinder Block on page 6-47</i>
	3TNV76	2.9925 - 2.9929 in. (76.010 - 76.020 mm)	3.0000 in. (76.200 mm)	
Cylinder Bore	Roundness	0.0004 in. (0.01 mm) or less	0.0012 in. (0.03 mm)	
	Taper			

ENGINE

SPECIAL TORQUE CHART

Torque for Bolts and Nuts



Component		Thread Diameter and Pitch	Tightening Torque	Lubricating Oil Application (Thread Portion and Seat Surface)	Reference Page
Cylinder Head Bolts		M9 x 1.25 mm	40 - 43 ft·lb (53.9 - 57.9 N·m; 5.5 - 5.9 kgf·m)	Applied	<i>See Reassembly of Cylinder Head on page 6-31</i>
Connecting Rod Bolts		M7 x 1.0 mm	17 - 20 ft·lb (22.6 - 27.5 N·m; 2.3 - 2.8 kgf·m)	Applied	<i>See Installation of Pistons on page 6-58</i>
Flywheel Bolts		M10 x 1.25 mm	59 - 64 ft·lb (80.4 - 86.4 N·m; 8.2 - 8.8 kgf·m)	Applied	<i>See Installation of Crankshaft on page 6-57</i>
Main Bearing Cap Bolts		M10 x 1.25 mm	56 - 60 ft·lb (75.5 - 81.5 N·m; 7.7 - 8.3 kgf·m)	Applied	<i>See Installation of Crankshaft on page 6-57</i>
Crankshaft Pulley Bolts	Cast FC250	M12 x 1.25 mm	61 - 69 ft·lb (83.4 - 93.1 N·m; 8.5 - 9.5 kgf·m)	Applied	<i>See Installation of Crankshaft on page 6-57</i>
	Forged PS48C		83 - 90 ft·lb (113 - 123 N·m; 11.5 - 12.5 kgf·m)		
Glow Plug		M10 x 1.25	11 - 15 ft·lb (14.7 - 19.6 N·m; 1.5 - 2.0 kgf·m)	Not Applied	<i>See Reassembly of Intake Manifold / Valve Cover on page 6-33</i>

See Tightening Torques for Standard Bolts and Nuts on page 4-24 for standard hardware torque values.

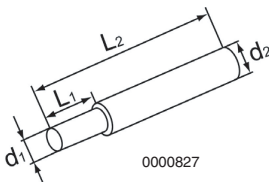
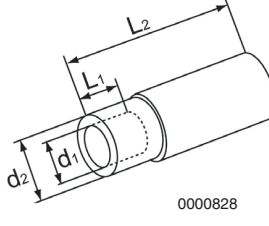
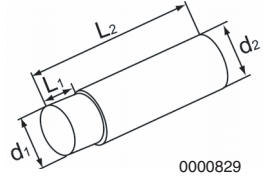
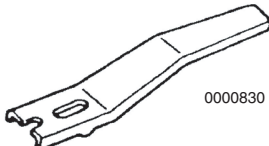

SPECIAL SERVICE TOOLS

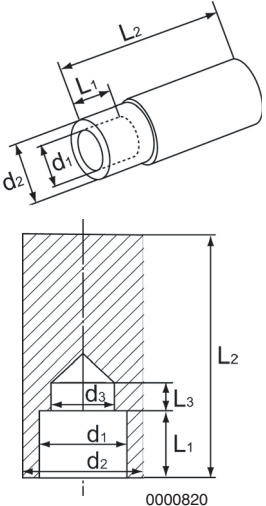
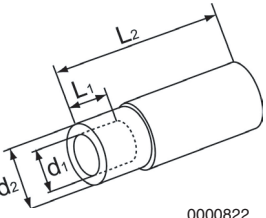
Note: Tools not having Yanmar part numbers must be acquired locally.

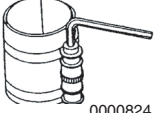
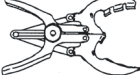
No	Tool Name	Applicable Model and Tool Size				Illustration
1	Valve Guide Tool (For Removing Valve Guides)	L1	L2	d1	d2	
		0.787 in. (20 mm)	2.953 in. (75 mm)	0.217 in. (5.5 mm)	0.374 in. (9.5 mm)	
		Locally Manufactured				
2	Valve Guide Tool (For Installing Valve Guides)	L1	L2	d1	d2	
		0.394 in. (10 mm)	2.362 in. (60 mm)	0.433 in. (11 mm)	0.669 in. (17 mm)	
		Locally Manufactured		Allowance L1: 0 to -0.0118 in. (0 to -0.3 mm)		
3	Wrist Pin Bushing Tool (For Removing / Installing of Wrist Pin Bushings)	L1	L2	d1	d2	
		0.984 in. (25 mm)	3.346 in. (85 mm)	0.866 in. (22 mm)	0.984 in. (25 mm)	
		Locally Manufactured		Allowance d1: -0.0118 to -0.0236 in. (-0.3 to -0.6 mm)	Allowance d2: -0.0118 to -0.0236 in. (-0.3 to -0.6 mm)	
4	Valve Spring Compressor (For Removing / Installing Valve Springs)	Yanmar Part No. 129100-92630				

No	Tool Name	Applicable Model and Tool Size	Illustration												
5	Stem Seal Tool (for Installing Stem Seals)	<table border="1" data-bbox="368 226 1141 360"> <thead> <tr> <th>d1</th> <th>d2</th> <th>d3</th> <th>L1</th> <th>L2</th> <th>L3</th> </tr> </thead> <tbody> <tr> <td>0.591 in. (15 mm)</td> <td>0.827 in. (21 mm)</td> <td>0.472 in. (12 mm)</td> <td>0.433 in. (11 mm)</td> <td>2.559 in. (65 mm)</td> <td>0.157 in. (4 mm) or more</td> </tr> </tbody> </table> <p data-bbox="608 483 900 595" style="text-align: center;"> Allowance: d1: ±0.00787 in. (±0.2 mm) L1: ±0.00393 in. (±0.1 mm) Locally Manufactured </p>	d1	d2	d3	L1	L2	L3	0.591 in. (15 mm)	0.827 in. (21 mm)	0.472 in. (12 mm)	0.433 in. (11 mm)	2.559 in. (65 mm)	0.157 in. (4 mm) or more	 <p data-bbox="1305 689 1369 707">0000820</p>
d1	d2	d3	L1	L2	L3										
0.591 in. (15 mm)	0.827 in. (21 mm)	0.472 in. (12 mm)	0.433 in. (11 mm)	2.559 in. (65 mm)	0.157 in. (4 mm) or more										
6	Camshaft Bushing Tool (For Removing Camshaft Bushing)	<table border="1" data-bbox="368 763 1141 869"> <thead> <tr> <th>L1</th> <th>L2</th> <th>d1</th> <th>d2</th> </tr> </thead> <tbody> <tr> <td>0.709 in. (18 mm)</td> <td>2.756 in. (70 mm)</td> <td>1.772 in. (45 mm)</td> <td>1.890 in. (48 mm)</td> </tr> </tbody> </table> <p data-bbox="443 931 676 958" style="text-align: center;">Locally Manufactured</p> <p data-bbox="772 875 1123 1016" style="text-align: center;"> Allowance d1: -0.0118 to -0.0236 in. (-0.3 to -0.6 mm) </p> <p data-bbox="975 875 1123 1016" style="text-align: center;"> Allowance d2: -0.0118 to -0.0236 in. (-0.3 to -0.6 mm) </p>	L1	L2	d1	d2	0.709 in. (18 mm)	2.756 in. (70 mm)	1.772 in. (45 mm)	1.890 in. (48 mm)	 <p data-bbox="1347 949 1410 967">0000822</p>				
L1	L2	d1	d2												
0.709 in. (18 mm)	2.756 in. (70 mm)	1.772 in. (45 mm)	1.890 in. (48 mm)												
7	Flex-Hone (For Preparing Cylinder Walls)	<table border="1" data-bbox="368 1066 1141 1171"> <thead> <tr> <th>Yanmar Part No.</th> <th>Cylinder Bore</th> </tr> </thead> <tbody> <tr> <td>129400-92410</td> <td>2.756 - 2.992 in. (70 - 76 mm)</td> </tr> </tbody> </table>	Yanmar Part No.	Cylinder Bore	129400-92410	2.756 - 2.992 in. (70 - 76 mm)	 <p data-bbox="1331 1267 1394 1285">0000823</p>								
Yanmar Part No.	Cylinder Bore														
129400-92410	2.756 - 2.992 in. (70 - 76 mm)														
8	Piston Ring Compressor (For Installing Pistons)	<p data-bbox="491 1339 1018 1424" style="text-align: center;"> Yanmar Part No. 955500-02476 The Piston Insertion Tool is Applicable for 2.362 - 4.921 in. (60 - 125 mm) Diameter Pistons </p>	 <p data-bbox="1299 1438 1362 1456">0000824</p>												
9	Piston Ring Tool (For Removing/ Installing of Piston Rings)	<p data-bbox="663 1525 847 1552" style="text-align: center;">Available Locally</p>	 <p data-bbox="1299 1585 1362 1603">0000825</p>												

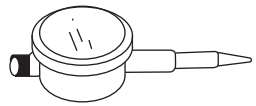
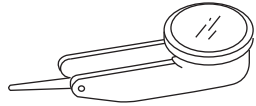
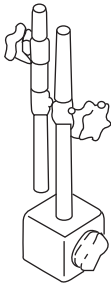
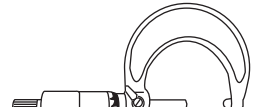
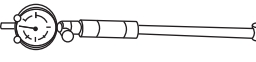
MEASURING INSTRUMENTS

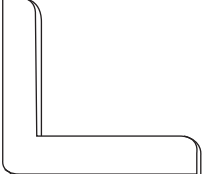
No.	Instrument Name	Application	Illustration
1	Dial Indicator (Available Locally)	Measure shaft bend and end play	 0000831
2	Test Indicator (Available Locally)	Measurements of narrow or deep portions that cannot be measured by dial gauge	 0000832
3	Magnetic Stand (Available Locally)	For holding the dial gauge when measuring.	 0000833
4	Micrometer (Available Locally)	For measuring the outside diameters of crankshaft, pistons, piston pins, etc.	 0000834
5	Cylinder Bore Gauge (Available Locally)	For measuring the inside diameters of cylinder liners, bearing bores, etc.	 0000835
6	Calipers (Available Locally)	For measuring outside diameters, depth, thickness and width	 0000836
7	Depth Micrometer (Available Locally)	For measuring of valve recession	 0000837
8	Square (Available Locally)	For measuring valve spring inclination and straightness of parts	 0000838

(Measuring instruments Cont.)

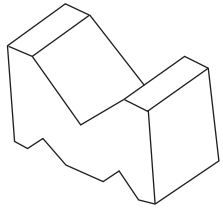
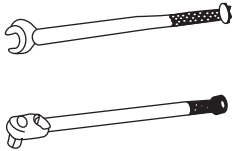
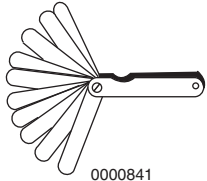
No.	Instrument Name	Application	Illustration
9	V-Block (Available Locally)	For measuring shaft bend	 <p>0000839</p>
10	Torque Wrench (Available Locally)	For tightening nuts and bolts to the specified torque	 <p>0000840</p>
11	Feeler Gauge (Available Locally)	For measuring piston ring gaps, piston ring clearance, and valve adjustment clearance	 <p>0000841</p>

This Page Intentionally Left Blank

CYLINDER HEAD

Cylinder Head Components

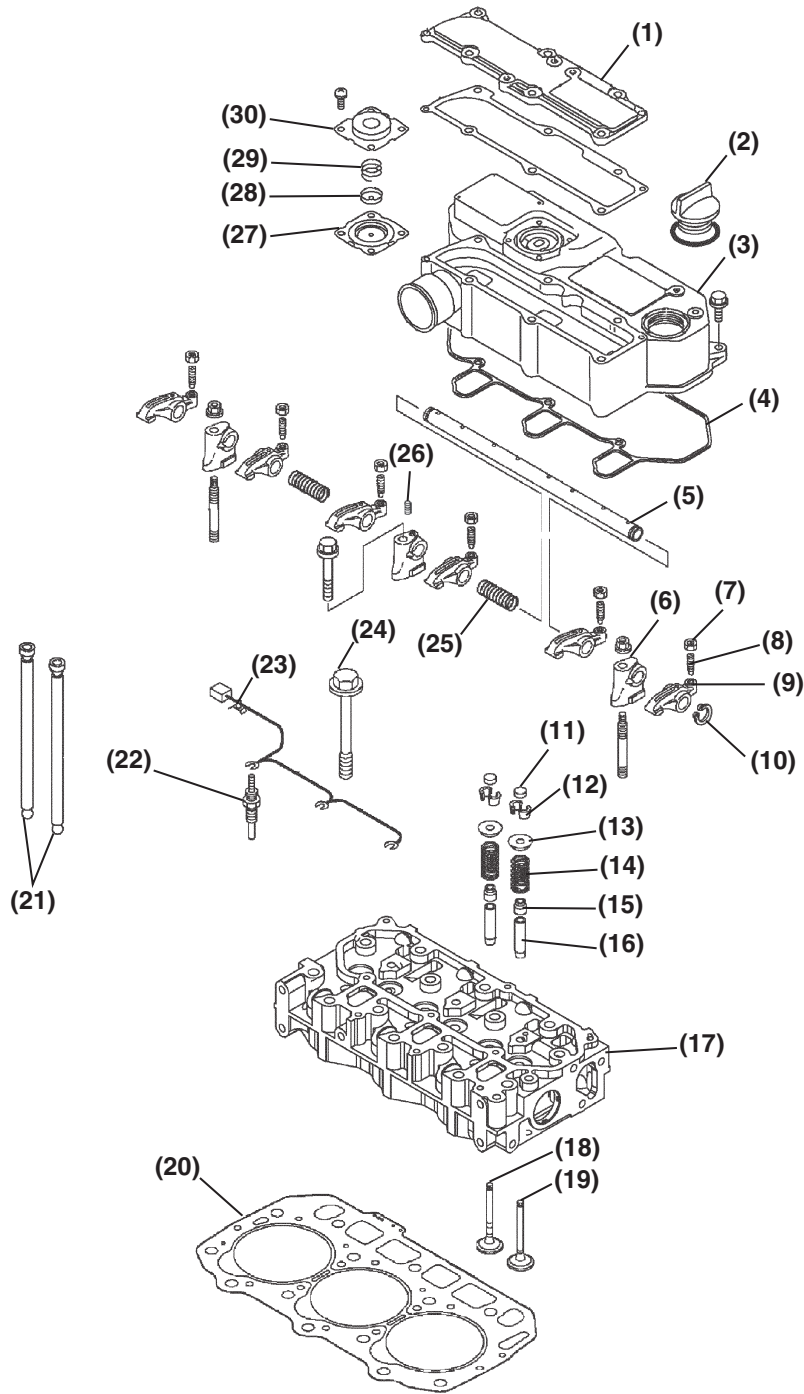

0002130

Figure 6-1

- 1 – Baffle Plate
- 2 – Oil Fill Cap
- 3 – Valve Cover / Intake Manifold
- 4 – Gasket
- 5 – Rocker Arm Shaft
- 6 – Rocker Arm Shaft Support
- 7 – Adjuster Lock Nut
- 8 – Valve Adjuster Screw
- 9 – Rocker Arm
- 10 – Circlip
- 11 – Valve Cap
- 12 – Keeper
- 13 – Valve Spring Retainer
- 14 – Valve Spring
- 15 – Valve Stem Seal
- 16 – Valve Guide
- 17 – Cylinder Head
- 18 – Exhaust Valve
- 19 – Intake Valve
- 20 – Cylinder Head Gasket
- 21 – Push Rod (2 per cylinder)
- 22 – Glow Plug
- 23 – Glow Plug Wiring Harness
- 24 – Cylinder Head Bolt

Disassembly of Cylinder Head

Prepare a clean, flat working surface on a workbench large enough to accommodate the cylinder head assembly. Discard all gaskets, O-rings and seals. Use new gaskets, O-rings and seals on reassembly of cylinder head.

IMPORTANT

Mark all valve train components so they can be installed in their original locations.

Note: Record all measurements taken during disassembly.

1. Drain coolant from engine into a suitable container. *See Drain, Flush and Refill Cooling System with New Coolant on page 5-33.*

CAUTION

Identify all parts and their location using an appropriate method. It is important that all parts are returned to the same position during the reassembly process.

0000080en

2. Remove the coolant pump. *See Disassembly of Engine Coolant Pump on page 8-7.*
3. Remove the high-pressure fuel lines and fuel injectors from the cylinder head. *See Removal of Fuel Injectors on page 7-23.*

Removal of Intake Manifold / Valve Cover

1. Remove the intake manifold bolts (Figure 6-2, (1)) and valve cover bolts (Figure 6-2, (2)).
2. Remove the valve cover / intake manifold (Figure 6-2, (3)). Discard gasket (Figure 6-2, (4)).

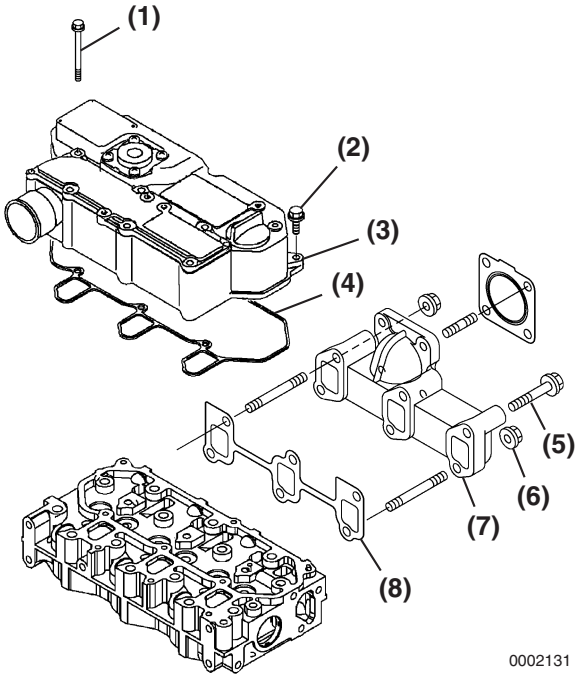

Figure 6-2

3. Remove the exhaust manifold bolts (Figure 6-2, (5)) and nuts (Figure 6-2, (6)). Remove the exhaust manifold (Figure 6-2, (7)) and the exhaust manifold gasket (Figure 6-2, (8)).

Removal of Glow Plugs

1. Disconnect the glow plug harness (Figure 6-3, (2)) from the glow plugs (Figure 6-3, (1)).
2. Remove the glow plugs from the cylinder head.

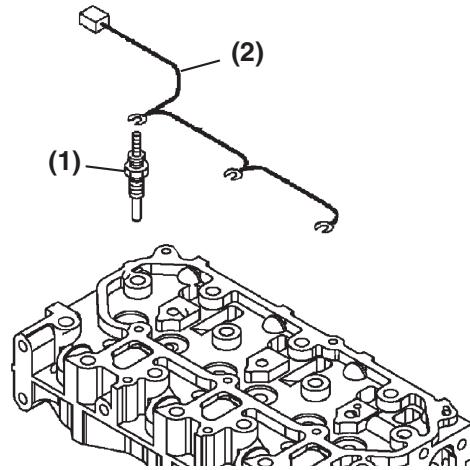

Figure 6-3

Removal of Rocker Arm Assembly

1. Remove the bolts (Figure 6-4, (1)) and nuts (Figure 6-4, (2)) that retain the rocker arm shaft supports.
 2. Remove the rocker arm shaft assembly from the cylinder head.
- Note: Identify the push rods so they can be reinstalled in their original locations.
3. Remove the push rods and identify for reinstallation.

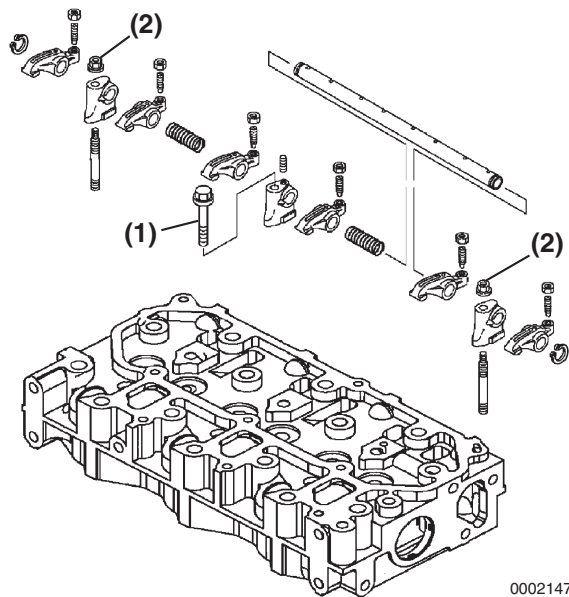

Figure 6-4

Disassembly of Rocker Arm Assembly

1. Remove the rocker arm shaft alignment set screw (**Figure 6-5, (6)**) from support (**Figure 6-5, (5)**).

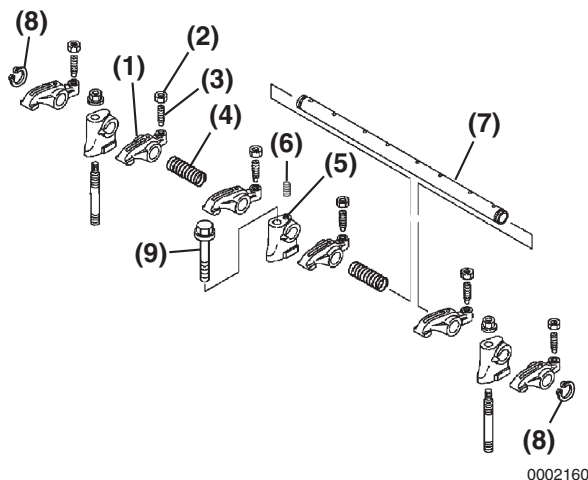

Figure 6-5

Note: On 3-cylinder models, the set screw is located in the center support. On 2-cylinder models, the set screw is located in the front (cooling fan) end support.

2. Remove two circlips (**Figure 6-5, (8)**).

Note: The rocker arm shaft fits tightly in the rocker arm supports. Clamp the support in a padded vise. Twist and pull out on the rocker arm shaft to remove. Reverse this process when installing the rocker arm shaft into the supports.

3. Slide the rocker arm shaft (**Figure 6-5, (7)**) out of the rocker arm supports (**Figure 6-5, (5)**), springs (**Figure 6-5, (4)**), and rocker arms (**Figure 6-5, (1)**).

Note: Mark the rocker arms so they can be reinstalled with the original matching valve and pushrod.

4. Remove the valve adjusting screw (**Figure 6-5, (3)**) and lock nut (**Figure 6-5, (2)**) from the rocker arms. Mark parts so they can be reinstalled on the same rocker arm.

Removal of Cylinder Head

1. Loosen the cylinder head bolts following the sequence shown in **Figure 6-6**.

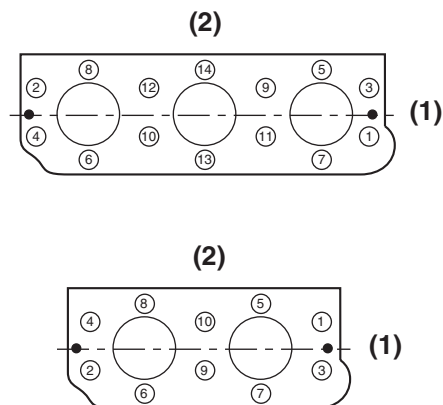

0002148

- 1 – Cooling Fan End
- 2 – Camshaft Side

Figure 6-6

2. Remove the cylinder head bolts (**Figure 6-7, (1)**).
3. Lift the cylinder head away from the cylinder block. Discard the cylinder head gasket (**Figure 6-7, (2)**). Position the cylinder head on the work bench to prevent damage to the combustion surface.

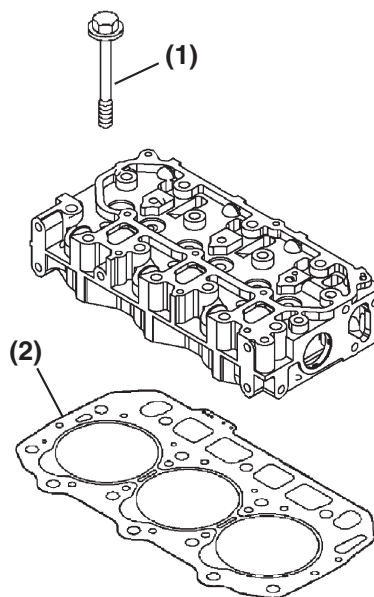

0002150

Figure 6-7

Removal of Intake / Exhaust Valves

1. Put the cylinder head on the work bench with the combustion side down (**Figure 6-8**).

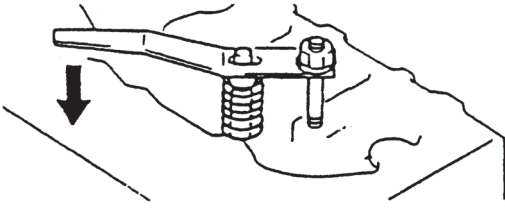

0000191

Figure 6-8

2. Remove the valve stem cap (**Figure 6-9, (1)**) and keep with the valve it was installed on.
3. Using the valve spring compressor tool, compress one of the valve springs (**Figure 6-8**).
4. Remove the valve keepers (**Figure 6-9, (2)**).
5. Slowly release the tension on the valve spring.
6. Remove the spring retainer (**Figure 6-9, (3)**) and valve spring (**Figure 6-9, (4)**).

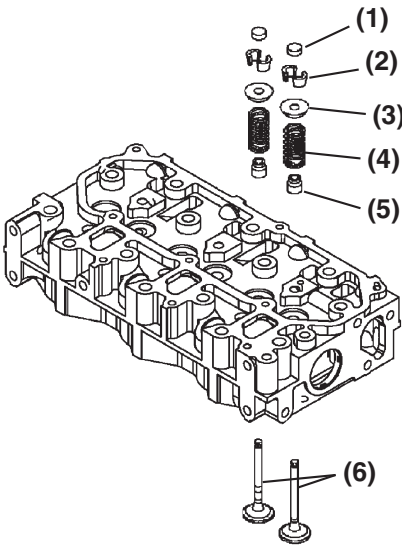

0002151

Figure 6-9

7. Repeat procedure with all remaining valves.

Note: If the valves are to be reused, identify them so they can be reinstalled in their original location.

8. Turn the cylinder head so the exhaust port side faces down. Remove the intake and exhaust valves (**Figure 6-9, (6)**) from the cylinder head.
9. Remove the valve stem seals (**Figure 6-9, (5)**).

Removal of Valve Guides

Note: Removal of valve guides should be postponed until inspection and measurement procedures have been performed. See *Inspection of Valve Guides* on page 6-26.

If the valve guides are not within specifications, use a drift pin and hammer to drive the valve guides (**Figure 6-10, (1)**) out of the cylinder head.

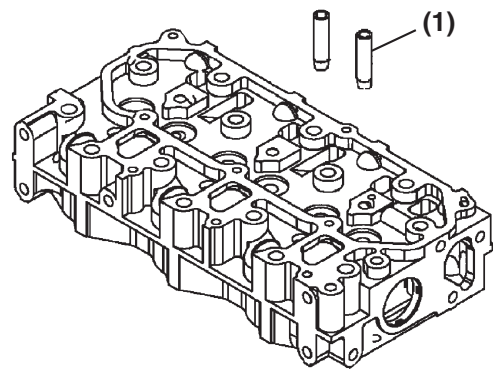

0002152

Figure 6-10

Cleaning of Cylinder Head Components

⚠ WARNING

<p style="text-align: center;">FUME / BURN HAZARD!</p> <ul style="list-style-type: none"> • Always read and follow safety related precautions found on containers of hazardous substances like parts cleaners, primers, sealants and sealant removers. • Failure to comply could result in death or serious injury. <p style="text-align: right; font-size: small;">0000014en</p>

Thoroughly clean all components using a non-metallic brush and an appropriate solvent. Each part must be free of carbon, metal filings and other debris.

Inspection of Cylinder Head Components

Visually inspect the parts. Replace any parts that are obviously discolored, heavily pitted or otherwise damaged. Discard any parts that do not meet its specified limits.

CAUTION
<p>Any part which is found defective as a result of inspection or any part whose measured value does not satisfy the standard or limit must be replaced.</p> <p style="text-align: right; font-size: small;">0000119en</p>

CAUTION

Any part determined to not meet the service standard or limit before the next service, as determined from the state of current rate of wear, should be replaced even though the part currently meets the service standard limit.

0000120en

IMPORTANT

Mark all valve train components so they can be installed in their original locations.

Note: Record all measurements taken during inspection.

Inspection of Push Rods

Push Rod Bend

Determine if the bend of the push rods is within the specified limit.

1. Place the push rods on a flat inspection block or layout bed.
2. Roll the push rods until a gap can be observed between a portion of the push rod and the surface of the block or layout bed.
3. Use a feeler gauge to measure the gap (**Figure 6-11**). See *Push Rod* on page 6-6 for the service limit.

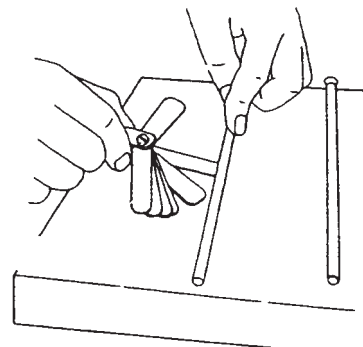

0000204

Figure 6-11

Inspection of Rocker Arm Assembly

Rocker Arm Shaft Hole Diameter

Use a telescoping gauge and micrometer to measure the inside diameter of all the rocker arm support brackets and the rocker arms (**Figure 6-12**). Record the measurements. See *Rocker Arm and Shaft on page 6-7 for the service limit*.

Inspect contact areas (**Figure 6-12, (1)**) for excessive wear or damage.

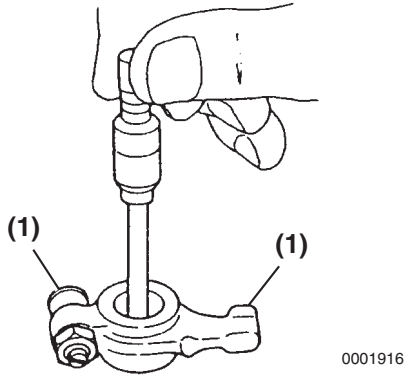

Figure 6-12

Rocker Arm Shaft Outside Diameter

Use a micrometer to measure rocker arm shaft diameter. Measure at each rocker arm location in two directions 90° apart (**Figure 6-13**). Record the measurements. See *Rocker Arm and Shaft on page 6-7 for the service limit*.

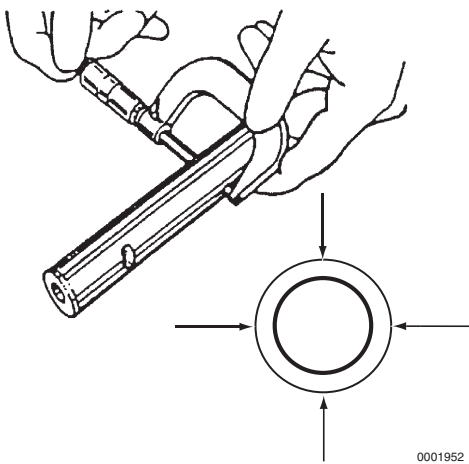

Figure 6-13

Inspection of Valve Guides

Visually inspect the valve guides for distortions, scoring or other damage.

Note: Measure valve guides while they are installed in cylinder head.

Use a telescoping gauge and micrometer to measure the inside diameter of the valve guide. Measure in three places and 90° apart (**Figure 6-14**). Record the measurements. See *Intake / Exhaust Valve and Guide on page 6-6 for the service limit*. Replace valve guides if not within specification.

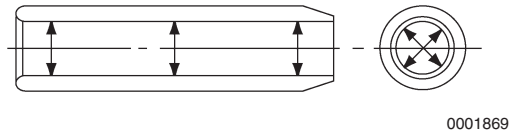

Figure 6-14

Inspection of Cylinder Head

Cylinder Head Distortion

Put the cylinder head flat and inverted (combustion side up) on the bench. Use a straightedge and feeler gauge to measure cylinder head distortion (**Figure 6-15**). Measure diagonally and along each side. Record the measurements. See *Cylinder Head on page 6-5 for the service limit*.

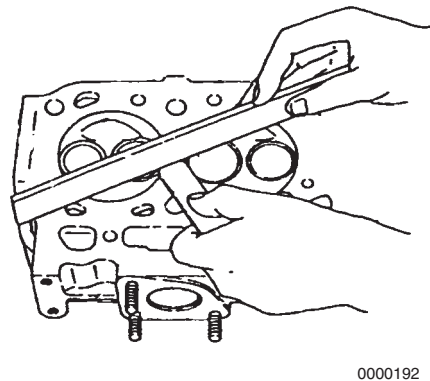

Figure 6-15

If distortion exceeds the service limit, resurface or replace the cylinder head. Remove only enough material to make the cylinder head flat, but do not remove more than 0.008 in. (0.20 mm).

Inspection of Intake and Exhaust Valves

Visually inspect the intake and exhaust valves. Replace any valves that are obviously discolored, heavily pitted or otherwise damaged.

Valve Stem Diameter

Use a micrometer to measure the valve stem diameter. Measure the valve stem near the combustion end and near the opposite end (**Figure 6-16, (1)**). Record the measurements. See *Intake / Exhaust Valve and Guide on page 6-6 for the service limit.*

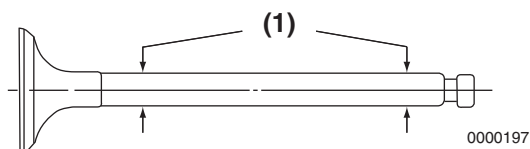

Figure 6-16

Valve Stem Bend

Place the valve stem on a flat inspection block or layout bed. Roll the valve until a gap can be observed between a portion of the valve stem and the surface of the block or bed. Use a feeler gauge to measure the gap (**Figure 6-17**). Record the measurements. See *Intake / Exhaust Valve and Guide on page 6-6 for the service limit.*

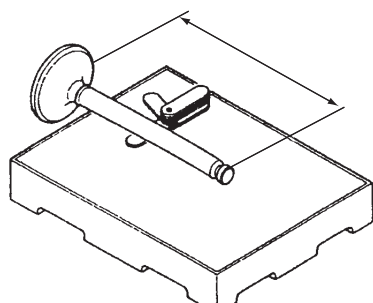

Figure 6-17

Valve Recession

Note: The valve guides must be installed to perform this check.

Insert the valves into their original locations and press them down until they are fully seated. Use a depth micrometer (**Figure 6-18**) to measure the difference between the cylinder head gasket surface and the combustion surface of each exhaust and intake valve (**Figure 6-19**). Record the measurements. See *Cylinder Head on page 6-5 for the service limit.*

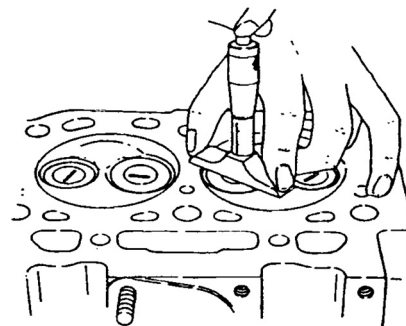

Figure 6-18

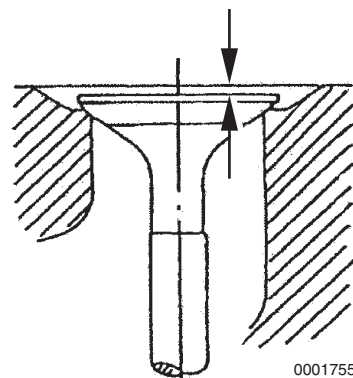

Figure 6-19

Valve Face and Valve Seat

Always check the clearance between the valve and valve guide before grinding or lapping the valve seats. See *Intake / Exhaust Valve and Guide on page 6-6 for the service limit*. If the clearance exceeds the limit, replace the valve and / or valve guide to bring the clearance within the limit.

Roughness or burrs will cause poor seating of a valve. Visually inspect the seating surfaces of each valve and valve seat to determine if lapping or grinding is needed.

Visually inspect all valve faces and valve seats for pitting, distortion, cracking, or evidence of overheating. Usually the valves and valve seats can be lapped or ground to return them to serviceable condition. Severely worn or damaged components will require replacement.

Coat the valve seat with a thin coat of bluing compound. Install valve and rotate to distribute bluing onto the valve face. The contact pattern should be approximately centered on the valve face (**Figure 6-20, (1)**) and even in width.

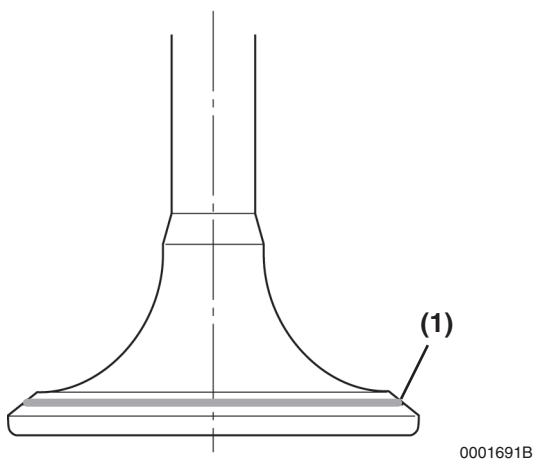
**Figure 6-20**

Also visually inspect the valve seat for even contact.

Light cutting can be performed by the use of a hand-operated cutter (**Figure 6-21, (3)**).

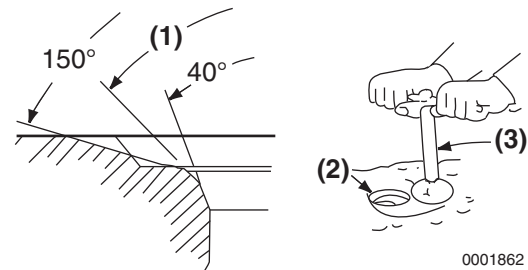
**Figure 6-21**

Valve seat diameter can be adjusted by top-grinding with a 150° stone to make the seat diameter smaller, and bottom-grinding using a 40° stone to make the seat diameter larger. Once the seat location has been corrected, grind and lap the seat angle (**Figure 6-21, (1)**) to specification. See *Cylinder Head on page 6-5 for the service limit*.

Grind the valve face and / or valve seat only enough to return them to serviceable condition. Grinding is needed if the valve and the valve seat do not contact correctly. Check the valve recession after grinding.

If the valve or seat require grinding, lap the valve after grinding. Lap the valve face to the valve seat using a mixture of valve lapping compound and engine oil.

Be sure to thoroughly wash all parts to remove all grinding powder or compound.

Inspection of Valve Springs

Inspect the valve springs. If damage or corrosion is seen, or if measurements exceed the specified limits, replace the springs. Record the measurements.

Fractures

Check for fractures on the inside and outside portions of the springs. If the valve spring is fractured, replace the valve spring.

Corrosion

Check for corrosion of spring material caused by oxidation.

Squareness

Use a flat surface and a square to check each spring for squareness (**Figure 6-22**). See *Valve Spring* on page 6-6 for the service limit.

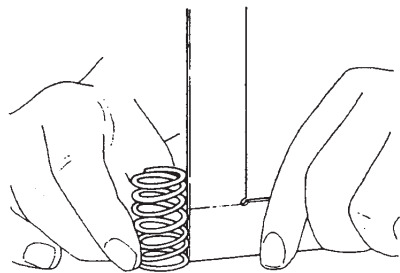

0000201

Figure 6-22**Free Length**

Use a caliper to measure the length of the spring (**Figure 6-23**). See *Valve Spring* on page 6-6 for the service limit.

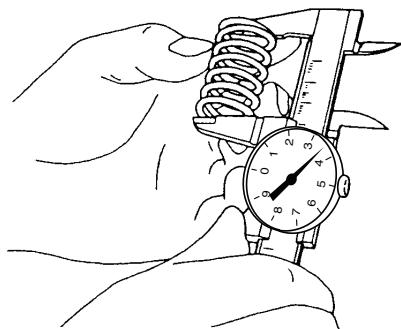

0000200

Figure 6-23**Reassembly of Cylinder Head**

Use new gaskets, O-rings and seals on reassembly of cylinder head.

IMPORTANT

Liberally oil all components during assembly to prevent premature wear or damage.

Reassembly of Valve Guides

1. The valve guides are installed into the cylinder head with an extremely tight press-fit. Before installing the valve guides, place the valve guides in a freezer for at least twenty minutes. This will cause the valve guides to contract, making it easier to install the valve guides in place.
2. Immediately after removing the valve guides from the freezer, insert the valve guides (**Figure 6-24, (1)**) in their proper positions.

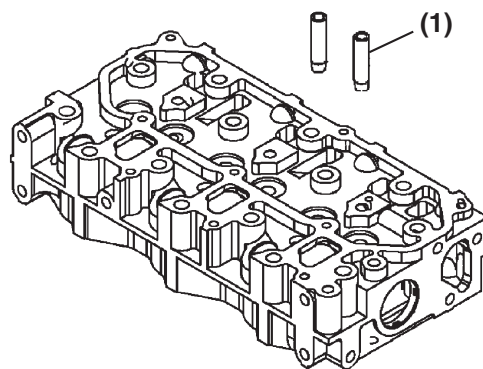

0002152

Figure 6-24

3. Finish installing the valve guides (Figure 6-25, (1)) to the proper height (Figure 6-25, (3)) using the valve guide installation tool (Figure 6-25, (2)). See valve guide projection specification on page 6-6.

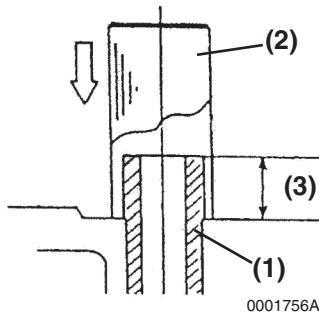

Figure 6-25

Reassembly of Intake and Exhaust Valves

IMPORTANT

Always install new valve stem seals.

The exhaust valve stem seals are different than the intake valve stem seals and can be identified by the color the seal spring (Figure 6-26, (4)). Ensure they are installed in the correct locations.

Engine Model	Marking	
	Intake	Exhaust
2TNV70, 3TNV70, 3TNV76	White (Seal Spring)	Black (Seal Spring)

1. Oil the lip of the valve stem seal (Figure 6-26, (2)). Using the valve stem seal installation tool (Figure 6-26, (1)), install a new valve stem seal on each of the valve guides (Figure 6-26, (3)).

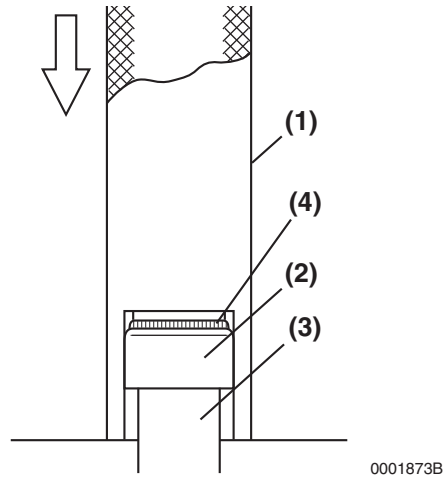

Figure 6-26

2. Measure the distance (Figure 6-27, (1)) from the cylinder head to valve stem seal to ensure proper clearance (Figure 6-27, (2)) between the valve guide and seal. See valve stem seal projection specification on page 6-6.

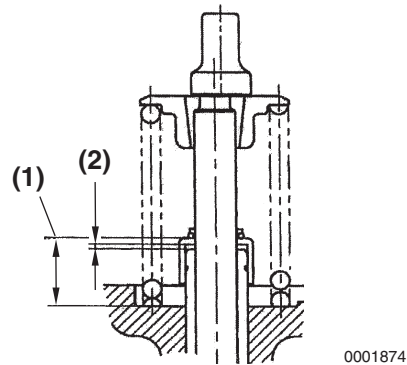
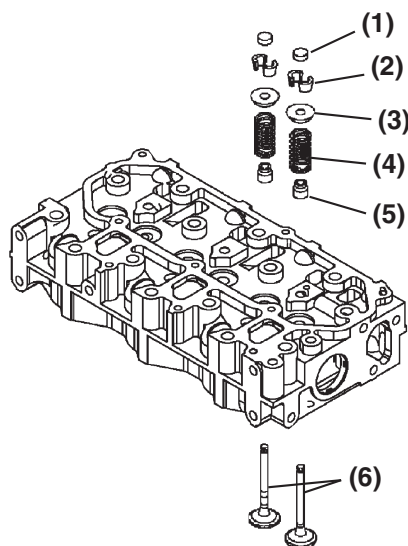

Figure 6-27

3. Put the cylinder head assembly on its exhaust port side.
4. Install all the valves (Figure 6-28, (6)) in their proper location in the cylinder head.



0002151

Figure 6-28

5. Put the cylinder head on the workbench with the combustion side down to install the valve springs. Reinstall the valve spring (Figure 6-28, (4)) and spring retainer (Figure 6-28, (5)).
6. Using a valve spring compressor tool, compress the valve spring.
7. Insert the valve keeper (Figure 6-28, (2)) and slowly release the tension in the valve spring. Reinstall the valve cap (Figure 6-28, (1)). Repeat steps on all remaining valves.

Reassembly of Cylinder Head

1. Carefully clean both the combustion surface of the cylinder head and the top surface of the cylinder block. Install a new cylinder head gasket (Figure 6-29, (2)) on the cylinder block.
2. Position the cylinder head on the cylinder head gasket.

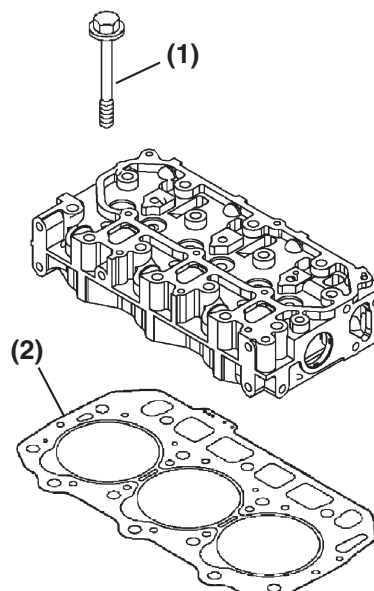

0002150

Figure 6-29

3. Lightly oil the threads of the cylinder head bolts (Figure 6-29, (1)). Tighten the bolts to the specified torque shown in the chart below. Tighten in the sequence shown in Figure 6-30. See Torque for Bolts and Nuts on page 6-14.

First Step	1/2 of final torque
Second Step	Final torque

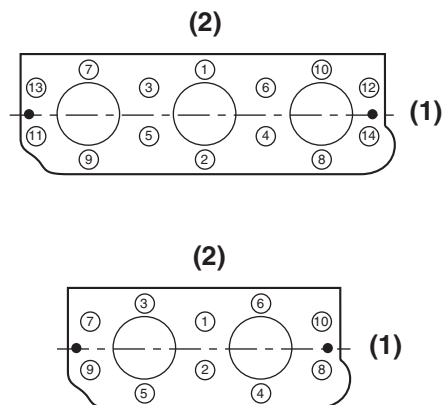

0002149

- 1 – Cooling Fan End
- 2 – Camshaft Side

Figure 6-30

4. Insert the push rods in their respective positions.

Reassembly of Rocker Arm Assembly

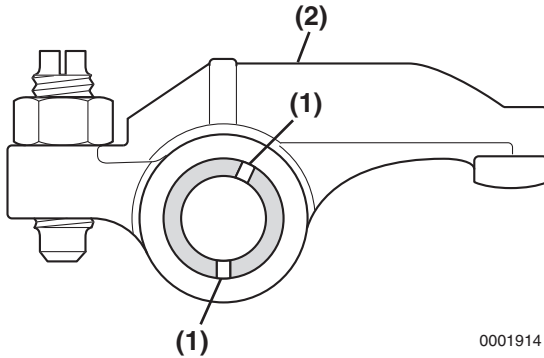

Figure 6-31

IMPORTANT

Ensure the lubrication holes in the rocker arm shaft (**Figure 6-31, (1)**) are oriented correctly with respect to the rocker arms (**Figure 6-31, (2)**).

1. Lubricate the rocker arm shaft. Slide the rocker arm supports (**Figure 6-32, (5)**), springs (**Figure 6-32, (4)**) and rocker arms (**Figure 6-32, (1)**) onto the shaft.

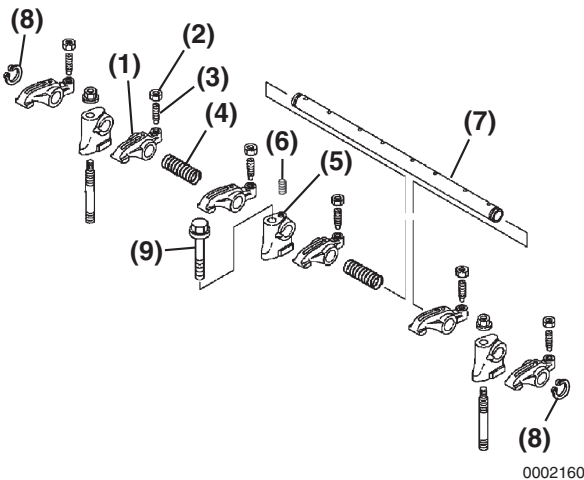

Figure 6-32

Note: The rocker arm shaft fits tightly in the rocker arm supports. Clamp the support in a padded vise. Twist and push on the rocker arm shaft to reinstall.

Note: On 3-cylinder models, the set screw is located in the center support. On 2-cylinder models, the set screw is located in the front (cooling fan) end support.

2. Align the hole in the rocker arm shaft (**Figure 6-32, (7)**) and the hole in the rocker arm support (**Figure 6-32, (5)**). Reinstall the alignment set screw (**Figure 6-32, (6)**).
3. Place the rocker arm shaft assembly onto the cylinder head.
4. If removed, reinstall the valve adjusting screws (**Figure 6-32, (3)**) and lock nuts (**Figure 6-32, (2)**).
5. Align the push rods with their respective rocker arms.
6. Reinstall and tighten the rocker arm shaft retaining bolts to the specified torque.
7. Tighten the rocker arm shaft alignment screw.
8. Adjust the valve clearance. See *Measuring and Adjusting Valve Clearance* on page 6-34.

Reassembly of Intake Manifold / Valve Cover

1. Reinstall the glow plugs (**Figure 6-33, (1)**) and tighten to specification. Reinstall the electrical harness (**Figure 6-33, (2)**).

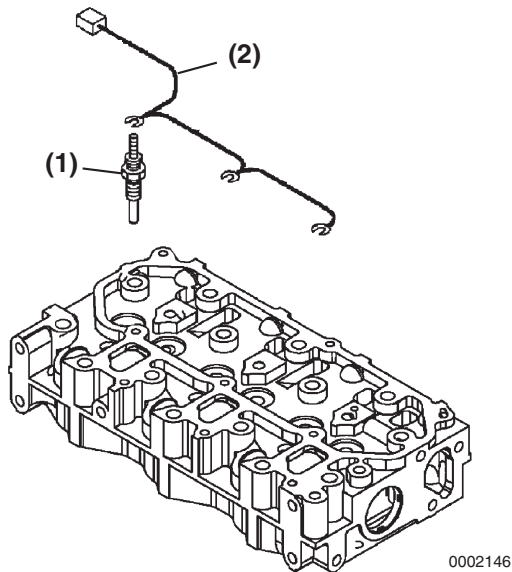

Figure 6-33

2. Lightly grease a new valve cover gasket (**Figure 6-34, (4)**). Place the gasket in the groove of the intake manifold / valve cover (**Figure 6-34, (3)**).
3. Place the valve cover on the cylinder head.
4. Reinstall and tighten bolts (**Figure 6-34, (1 and 2)**) securely.

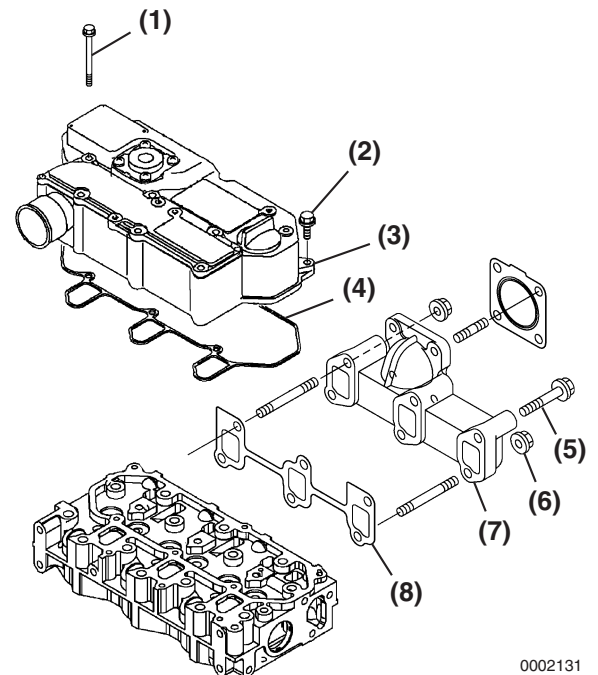

Figure 6-34

5. Reinstall the exhaust manifold using a new gasket. Tighten the bolts and nuts (**Figure 6-34, (5 and 6)**) securely.
6. Reinstall the fuel injectors. *See Installation of the Fuel Injectors on page 7-29.*
7. Reinstall the high pressure and return fuel injection lines. *See Installation of the Fuel Injectors on page 7-29.*
8. Reinstall the coolant pump. *See Reassembly of Engine Coolant Pump on page 8-9.*
9. Reinstall the alternator. *See Installation of Alternator on page 11-16.*

Measuring and Adjusting Valve Clearance

Measure and adjust while the engine is cold.

Notes:

- The No. 1 piston position is on the flywheel end of the engine, opposite end of the radiator. The firing order is 1-3-2 for 3-cylinder engines and 1-2 for 2-cylinder engines.
- 3-cylinder engines fire every 240° of crankshaft rotation.
- 2-cylinder engines are an uneven firing engine. No. 2 cylinder fires 180° after No. 1. The crankshaft then rotates 540° before No. 1 cylinder fires again.
- Valve clearance of both the intake and exhaust valves can be checked with the piston for that cylinder at top dead center (TDC) of the compression stroke. When a piston is at TDC of the compression stroke, both rocker arms will be loose and the cylinder TDC mark on the flywheel will be visible in the timing port of the flywheel housing.

- If there is no valve clearance, and the piston is at TDC of the compression stroke, extreme wear or damage to the cylinder head or valves may be possible.
- If adjusting each cylinder individually, the cylinder to be adjusted first does not have to be the No. 1 cylinder. Select and adjust the cylinder where the piston is nearest to the top dead center after turning. Adjust the remaining cylinders in the order of firing by turning the crankshaft each time.
- To decrease the number of rotations required to check all cylinders of a 3-cylinder engine, other cylinders can also be checked as indicated in the chart below. 2-cylinder engines must have each cylinder adjusted when the piston is at TDC.

Example: On a 3-cylinder engine, with the No. 1 piston at TDC on the compression stroke (both valves closed), the valves indicated on the top line of the chart can be adjusted without rotating the crankshaft. To adjust the remaining two valves, rotate the crankshaft until the No. 1 piston is at TDC on the exhaust stroke (exhaust valve only open).

3-Cylinder Engines

Cylinder No.	1		2		3	
	Intake	Exhaust	Intake	Exhaust	Intake	Exhaust
No. 1 Cylinder at TDC Compression	•	•	•			•
No. 1 Cylinder at TDC Exhaust				•	•	

1. Remove the intake manifold / valve cover. See *Removal of Intake Manifold / Valve Cover on page 6-22.*
2. Rotate the crankshaft clockwise as seen from the coolant pump end, to bring No. 1 piston to TDC of the compression stroke while watching the rocker arm motion and timing grid on the flywheel. (Position so both the intake and exhaust valves are closed.)
3. Insert a feeler gauge (**Figure 6-35, (1)**) between rocker arm and valve cap and record the measured valve clearance. (Use the data for estimating wear.)

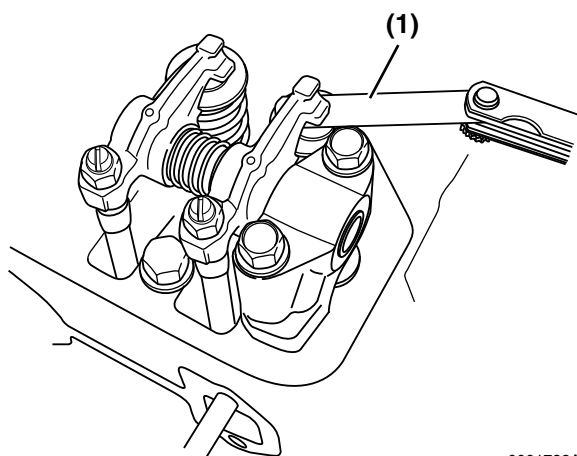

0001782A

Figure 6-35

4. If adjustment is required, proceed to the next step.
5. Loosen the valve adjusting screw lock nut (**Figure 6-36, (1)**) and valve adjusting screw (**Figure 6-36, (2)**) on the rocker arm. Check the valve for inclination of the valve cap, entrance of dirt, or wear.

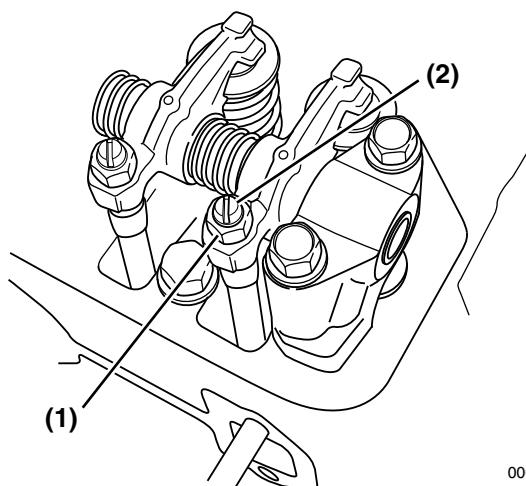

0001783A

Figure 6-36

6. Insert a feeler gauge of the correct thickness (**Figure 6-37, (1)**) between rocker arm and valve cap. Turn the valve adjustment screw to adjust the valve clearance so there is a slight "drag" on the feeler gauge when sliding it between the rocker arm and valve cap. Hold the adjusting screw while tightening the valve adjusting screw lock nut (**Figure 6-36, (1)**). Recheck the clearance (*see Adjustment Specifications on page 6-5*).

Note: There is a tendency for the clearance to decrease slightly when the lock nut is tightened. It is suggested that the initial clearance adjustment be made slightly on the "loose" side before tightening the lock nut.

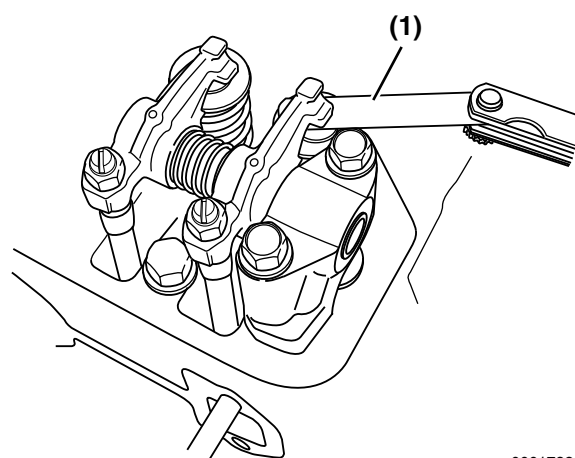

0001782A

Figure 6-37

7. Apply oil to the contact surface between adjusting screw and push rod.
8. Rotate the crankshaft and measure the next cylinder. Continue until all valves are adjusted.

CYLINDER BLOCK

Crankshaft and Camshaft Components

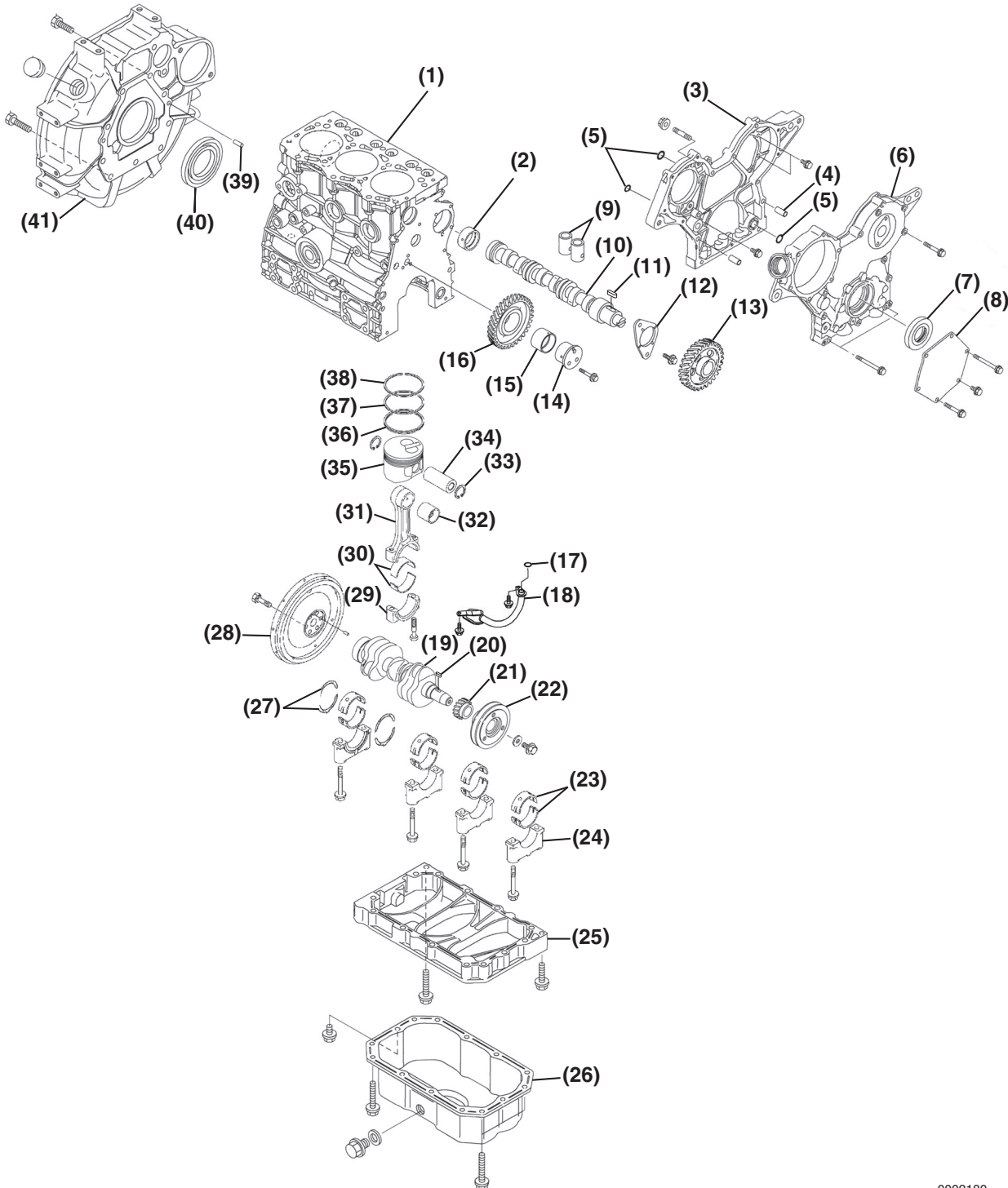

Figure 6-38

00021R0

- 1 – Cylinder Block
- 2 – Camshaft Bushing
- 3 – Gear Case
- 4 – Dowel (2 used)
- 5 – O-Ring
- 6 – Gear Case Cover
- 7 – Front Crankshaft Seal
- 8 – Fuel Injection Pump Gear Cover
- 9 – Tappets
- 10 – Camshaft
- 11 – Camshaft Gear Key
- 12 – Camshaft End Plate
- 13 – Camshaft Gear
- 14 – Idler Gear Shaft
- 15 – Idler Gear Bushing
- 16 – Idler Gear
- 17 – Oil Pickup O-Ring
- 18 – Oil Pickup
- 19 – Crankshaft
- 20 – Crankshaft Gear Key
- 21 – Crankshaft Gear
- 22 – Crankshaft Pulley
- 23 – Main Bearing Inserts
- 24 – Main Bearing Cap
- 25 – Crankcase Extension
- 26 – Oil Pan
- 27 – Thrust Bearings
- 28 – Flywheel
- 29 – Connecting Rod Cap
- 30 – Connecting Rod Bearing Inserts
- 31 – Connecting Rod
- 32 – Wrist Pin Bushing
- 33 – Circlip
- 34 – Wrist Pin
- 35 – Piston
- 36 – Oil Ring
- 37 – Second Compression Ring
- 38 – Top Compression Ring
- 39 – Dowel (2 used)
- 40 – Crankshaft Rear Seal
- 41 – Flywheel Housing

Disassembly of Cylinder Block Components

Prepare a clean, flat working surface on a workbench large enough to accommodate the engine components. Discard all used gaskets, O-rings and seals. Use new gaskets, O-rings and seals for reassembly of engine.

CAUTION

Identify all parts and their location using an appropriate method. It is important that all parts are returned to the same position during the reassembly process.

0000080en

IMPORTANT

Mark all valve train components so they can be installed in their original locations.

Note: Record all measurements taken during disassembly.

If the engine will be completely disassembled, the following preliminary steps should be performed:

1. Disconnect the battery cables at the battery. Always disconnect the negative (-) cable first.
2. Remove the throttle cable, electrical connections, intake and exhaust system connections, and fuel supply lines from the engine.
3. Remove the alternator. *See Removal of Alternator on page 11-12.*
4. Drain the engine coolant from the radiator and cylinder block. *See Drain, Flush and Refill Cooling System with New Coolant on page 5-33.* Remove the cooling system components from the engine.

CAUTION

Be sure to secure the engine solidly to prevent injury or damage to parts due to the engine falling during work on the engine.

0000009en

5. Remove the engine from the machine. Mount the engine to a suitable engine repair stand having adequate weight capacity.
6. Clean the engine by washing with solvent, air or steam cleaning. Carefully operate to prevent any foreign matter or fluids from entering the engine, fuel system, or electrical components remaining on the engine.
7. Drain the engine oil into a suitable container. Remove oil filter.
8. Remove the cylinder head. *See Disassembly of Cylinder Head on page 6-21.*
9. Remove the fuel injection pump from the gear case only if it must be sent out for repair, or will interfere with other procedures such as "hot tank" cleaning. *See Removal of Fuel Injection Pump on page 7-13.*
10. Remove the starter motor. *See Removal of Starter Motor on page 10-10.*

Disassembly of Camshaft and Timing Components

Discard all gaskets, O-rings and seals. Use new gaskets, O-rings and seals on reassembly of camshaft and timing components.

Removal of Timing Gear Case Cover

1. Remove the bolt and washer retaining the crankshaft pulley.

IMPORTANT

Use care not to damage the threads in the end of the crankshaft when removing the crankshaft pulley.

2. Remove the crankshaft pulley with a gear puller.
3. Remove the bolts that retain the gear case cover to the cylinder block and oil pan.
4. Remove the gear case cover (**Figure 6-39, (1)**).
5. Remove the dowel pins (**Figure 6-39, (3)**) and O-ring (**Figure 6-39, (2)**).

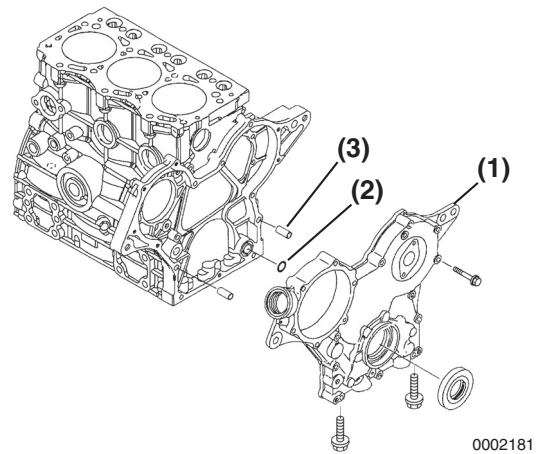
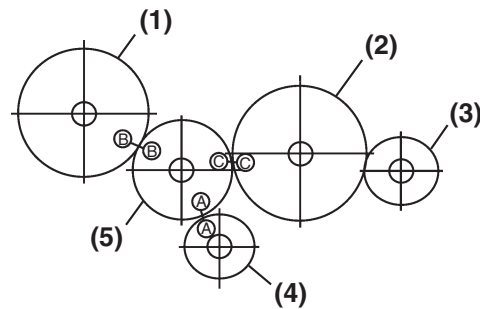

Figure 6-39

Checking Timing Gear Backlash

Prior to removing the timing gears, measure the gear backlash and determine the gear wear.

Note: Check the backlash between each pair of mating gears. If not within specification, replace both mating gears. Do not allow the gear being checked to move axially as excess end play could cause a false reading. *See Timing Gear Backlash on page 6-8 for service limits.*



- 1 – Fuel Injection Pump Drive Gear
- 2 – Camshaft Drive Gear
- 3 – Auxiliary Drive Gear (Optional)
- 4 – Crankshaft Drive Gear
- 5 – Idler Gear

Figure 6-40

Measuring Idler Gear-to-Crankshaft Gear Backlash

1. Install a dial indicator as shown in **Figure 6-41**.

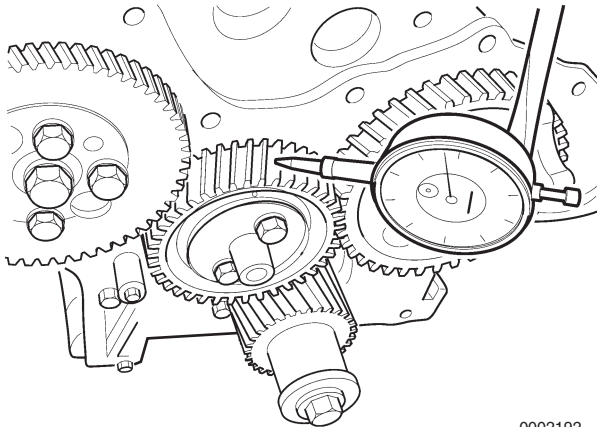

0002192

Figure 6-41

2. Rotate the idler gear back and forth to check idler gear-to-crankshaft gear backlash. Total indicator reading is backlash. Record the measurement.

Measuring Idler Gear-to-Camshaft Gear Backlash

1. Drive a small wooden wedge between the crankshaft gear and idler gear to prevent the idler gear from rotating.
2. Install a dial indicator to read camshaft gear backlash. Rotate camshaft drive gear against idler gear to measure backlash. Record the measurement.
3. Check the idler gear-to-fuel injection pump drive gear backlash in the same manner as the camshaft drive gear. Record the measurement.

Removal of Timing Gears

1. Remove the bolts from the idler gear shaft (**Figure 6-42, (1)**). Remove the idler gear shaft, idler gear (**Figure 6-42, (3)**) and bushing (**Figure 6-42, (2)**).

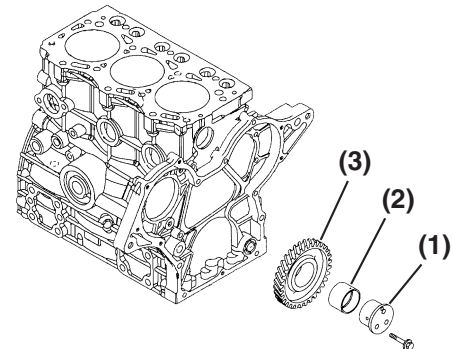

00021

Figure 6-42

2. Do not remove the crankshaft gear unless it is damaged and requires replacement. If the gear must be removed, remove it with a gear puller.
3. Removal of the camshaft gear requires the camshaft be removed with a press. Do not remove the camshaft gear unless it or the camshaft is damaged and requires replacement. *See Removal of Camshaft on page 6-41.*

CAUTION

Do not loosen or remove the four bolts retaining the fuel injection pump drive gear to the fuel injection pump hub. Do not disassemble the fuel injection pump drive gear from the hub. Correct fuel injection timing will be very difficult or impossible to achieve.

0000031en

4. Do not remove the fuel injection pump drive gear unless absolutely necessary due to damage to the gear or pump. Do not loosen or remove the four bolts (**Figure 6-43, (3)**) retaining pump drive gear to the hub. Only remove the nut (**Figure 6-43, (1)**) and washer (**Figure 6-43, (2)**), leaving the hub attached to the gear. Remove the pump drive gear and hub as an assembly using a gear puller.

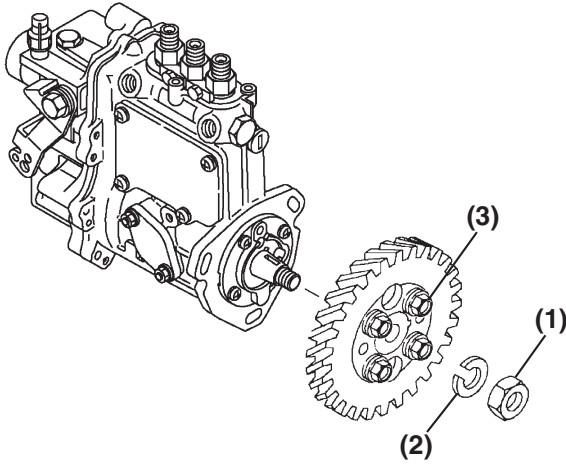

0002183

Figure 6-43

CAUTION

Do not loosen or remove the four bolts retaining the fuel injection pump drive gear to the fuel injection pump hub. Do not disassemble the fuel injection pump drive gear from the hub. Correct fuel injection timing will be very difficult or impossible to achieve.

0000031en

Removal of Oil Pan

1. Invert the engine (oil pan up) on the engine stand.
2. Remove the oil pan (**Figure 6-44, (2)**).
3. Remove the crankcase extension (**Figure 6-44, (1)**) if equipped.

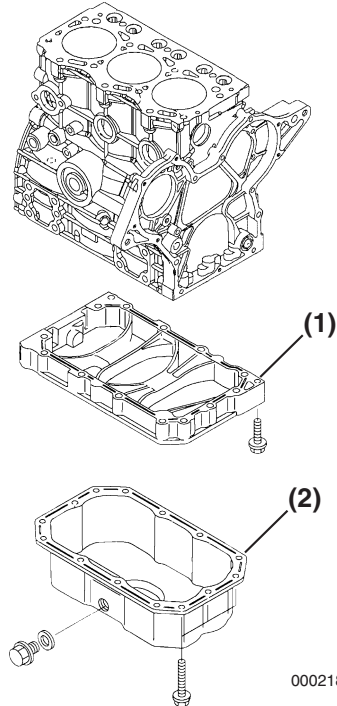

0002184

Figure 6-44

4. Remove the oil pickup tube (**Figure 6-45, (1)**) and O-ring (**Figure 6-45, (2)**).

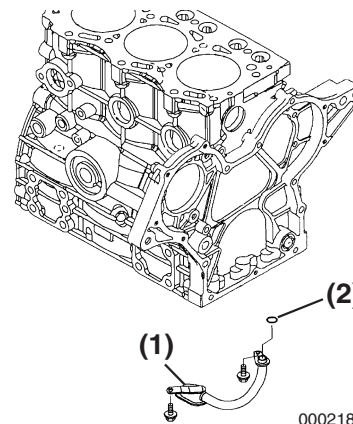

0002185

Figure 6-45

Removal of Camshaft

1. Before removing the camshaft, check the camshaft end play.
 - **Method A:** Install a dial indicator (**Figure 6-46, (1)**) on the cylinder block. Move the camshaft and gear (**Figure 6-46, (2)**) in and out to measure the end play. Record the measurement. See *Camshaft* on page 6-7 for the service limit.

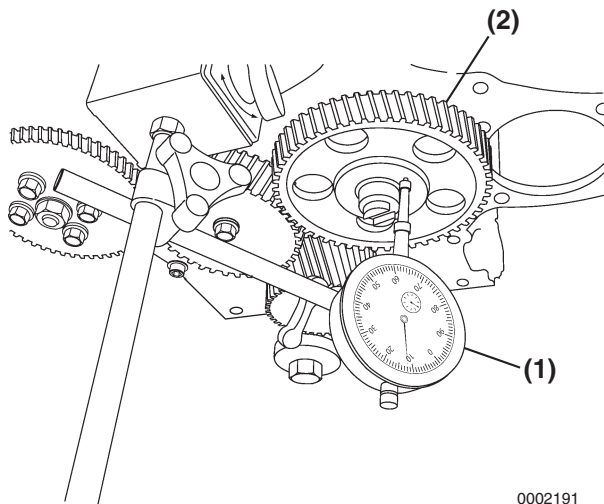

Figure 6-46

- **Method B:** Use a feeler gauge to measure the clearance between the thrust plate (**Figure 6-47, (1)**) and front camshaft bearing (**Figure 6-47, (2)**). Record the measurement. See *Thrust Bearing* on page 6-9 for the service limit.

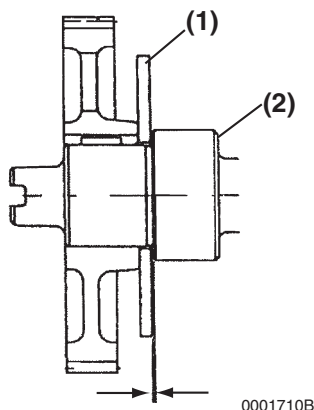

Figure 6-47

2. Remove two bolts (**Figure 6-48, (3)**) retaining the camshaft thrust plate (**Figure 6-48, (1)**).

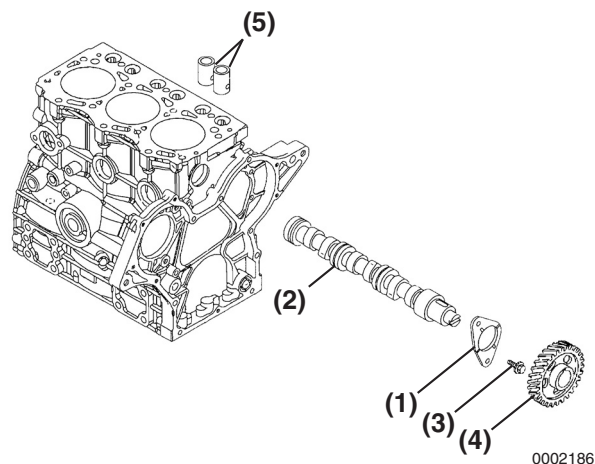

Figure 6-48

3. Extract the tappets (**Figure 6-48, (5)**) through the top of the cylinder block. Mark the tappets so they can be reinstalled in the same location.
4. Slowly pull the camshaft (**Figure 6-48, (2)**) assembly out of the engine being careful not to damage the front camshaft bushing.
5. Remove the camshaft gear (**Figure 6-48, (4)**) only if the gear or camshaft require replacement. Use a knife-edge puller and a press to remove the gear. The gear is a shrink-fit and will need to be heated to 356° - 392°F (180° - 200°C) to remove.

Removal of Gear Case

Note: The camshaft must be removed before the gear case can be removed. See *Removal of Camshaft* on page 6-41.

1. Remove bolts (**Figure 6-49, (4)**).

Note: It is not necessary to remove the fuel injection pump from the gear case to remove the gear case. If the fuel injection pump does not need to be repaired, leave it mounted to the timing gear case. See *Removal of Fuel Injection Pump* on page 7-13.

2. Remove the gear case (**Figure 6-49, (1)**) from the cylinder block.
3. Inspect and measure the camshaft bushing. See *Camshaft* on page 6-7 for service limits. If damaged or worn beyond service limits, remove the camshaft bushing (**Figure 6-49, (3)**).
4. Remove O-rings (**Figure 6-49, (2)**).

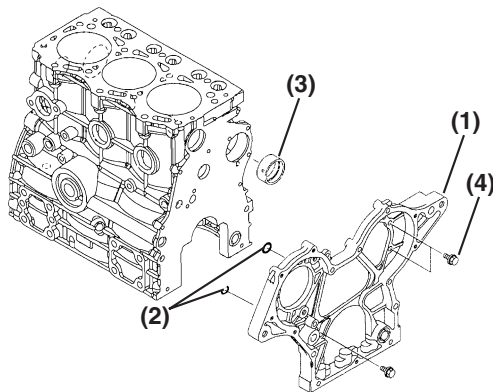

0002187

Figure 6-49

Disassembly of Crankshaft and Piston Components

Removal of Pistons

CAUTION

Keep the piston pin parts, piston assemblies, and connecting rod assemblies together to be returned to the same position during the reassembly process. Label the parts using an appropriate method.

0000088en

IMPORTANT

Engines with high operating hours may have a ridge near the top of the cylinders that will catch the piston rings and make it impossible to remove the pistons. Use a suitable ridge reamer to remove ridges and carbon prior to removing pistons.

Note: Pistons can fall from cylinder block if engine is inverted. Rotate the engine so the connecting rods are horizontal before removing the connecting rod caps.

- Using a feeler gauge, measure the connecting rod side clearance (**Figure 6-50**). See *Connecting Rod* on page 6-12 for the standard limit. If the measurement is out of specification, replace the crankshaft, connecting rod, or both.

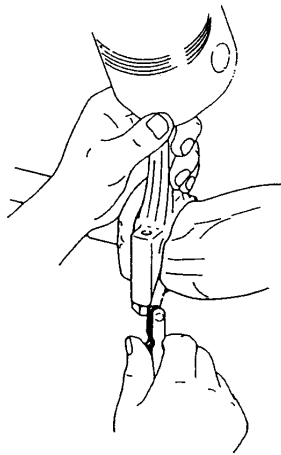

0000219

Figure 6-50**IMPORTANT**

Mark the connecting rod caps and connecting rods so the caps and connecting rods stay together.

- Remove the bearing cap. Do not remove the bearing inserts at this time.
- Wipe oil from the bearing insert and crankshaft journal surfaces.
- Place a piece of PLASTIGAGE® (**Figure 6-51, (1)**) along the full width of the bearing insert.

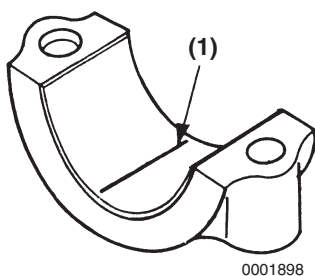

0001898

Figure 6-51**IMPORTANT**

Do not rotate crankshaft when using PLASTIGAGE. A false reading may result.

- Reinstall the bearing cap and tighten to specification. See *Special Torque Chart* on page 6-14.
- Remove the bearing cap.

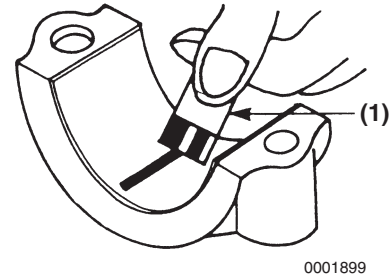

0001899

Figure 6-52

- Compare the width of the flattened PLASTIGAGE (**Figure 6-52, (1)**) to the graduation marks on the package. The mark that most closely matches the width of the flattened PLASTIGAGE will indicate the bearing oil clearance. Record the measurements. See *Crankshaft* on page 6-8.
- Repeat with the remaining connecting rods.

IMPORTANT

Do not allow the connecting rod to contact the crankshaft journal during piston removal. Damage to the bearing journal may result.

- Use a wooden dowel against the connecting rod and tap the piston / connecting rod assembly out of the cylinder.
- Mark the cylinder number on the piston and connecting rod.

11. Remove the bearing inserts (**Figure 6-53, (2)**).
12. Remove the compression rings (**Figure 6-53, (3)**) from the piston using a piston ring expander.
13. Remove the oil ring (**Figure 6-53, (4)**) from the piston using a piston ring expander.

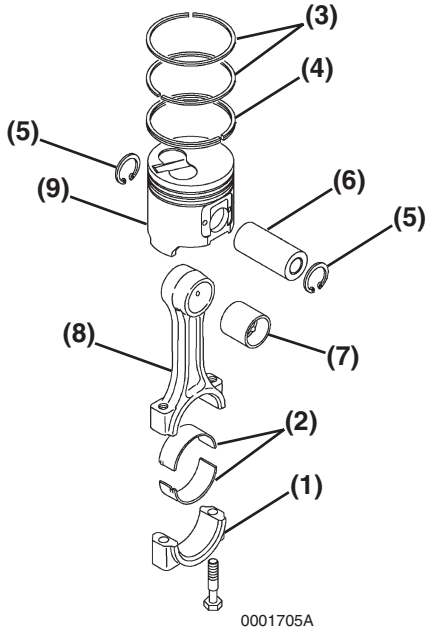

Figure 6-53

14. Remove the circlips (**Figure 6-53, (5)**) from the wrist pin.
15. Remove the wrist pin (**Figure 6-53, (6)**) and connecting rod (**Figure 6-53, (8)**) from the piston (**Figure 6-53, (9)**).
16. Repeat steps until all pistons are removed and disassembled.

Removal of Crankshaft

1. Remove the flywheel (**Figure 6-54, (1)**) from the crankshaft.
2. Remove the bolts (**Figure 6-54, (2)**) from the flywheel housing assembly. Remove the flywheel housing from the engine.

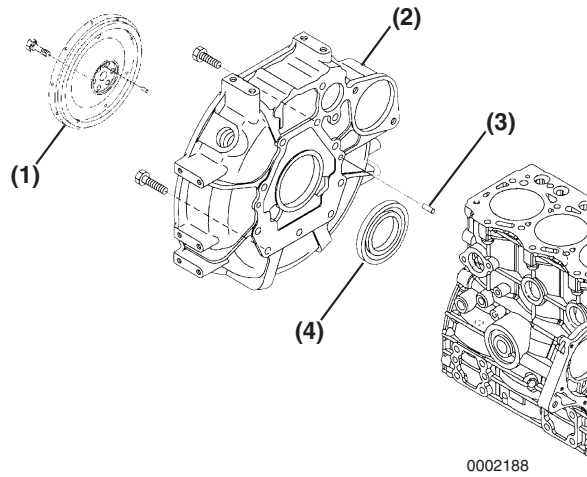

Figure 6-54

3. Before removing the main bearing caps, measure the crankshaft end play. Use either of the following two methods:
 - **Method A:** Install a dial gauge (**Figure 6-55, (1)**) on the cylinder block. Move the crankshaft (**Figure 6-55, (2)**) in and out to measure the end play. Record the measurement.

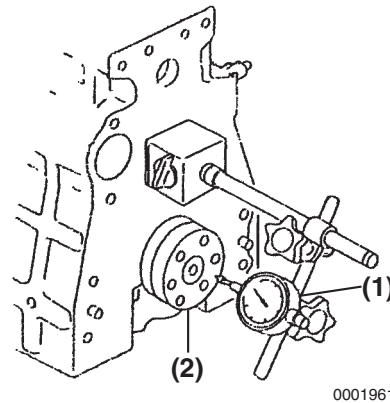

Figure 6-55

- **Method B:** Use a feeler gauge to measure the clearance (**Figure 6-56, (3)**) between the thrust bearing (**Figure 6-56, (1)**) and crankshaft (**Figure 6-56, (2)**). Record the measurement. See *Thrust Bearing on page 6-9 for the service limit.*

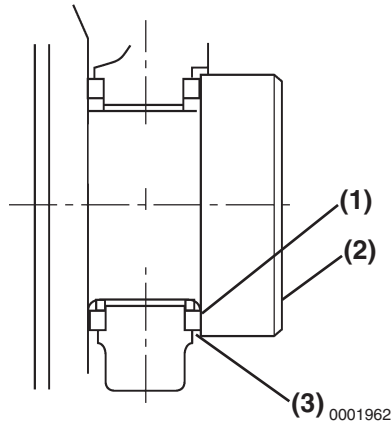

Figure 6-56

4. Remove the bearing cap. Do not remove the bearing inserts at this time.
5. Wipe oil from the bearing insert and crankshaft journal surfaces.
6. Place a piece of PLASTIGAGE® (**Figure 6-57, (1)**) along the full width of the bearing insert.

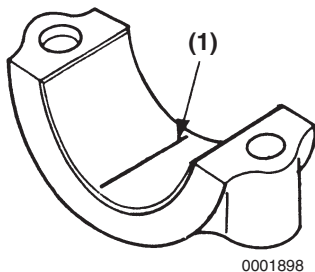

Figure 6-57

IMPORTANT

Do not rotate crankshaft when using PLASTIGAGE. A false reading may result.

7. Reinstall the bearing cap and tighten to specification. See *on page 6-14.*
8. Remove the bearing cap.

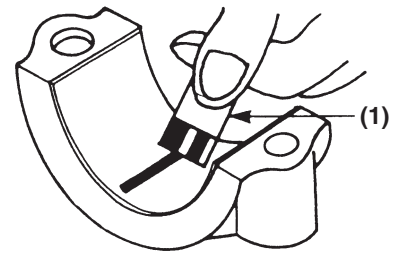

Figure 6-58

9. Compare the width of the flattened PLASTIGAGE (**Figure 6-58, (1)**) to the graduation marks on the package. The mark that most closely matches the width of the flattened PLASTIGAGE will indicate the bearing oil clearance. Record the measurement. See *Crankshaft on page 6-8 for clearance specifications.*

10. Repeat with the remaining main bearings.

Note: Be sure to note the markings on the main bearing caps, or make marks so they can be reinstalled in the same order as they were removed. The “arrows” on the main bearing caps point to the flywheel end of the engine.

11. Remove the crankshaft from the engine.
12. Remove the bearing inserts (**Figure 6-59, (1)**) and thrust bearings (**Figure 6-59, (2)**).

Note: Do not remove the crankshaft gear unless the gear or crankshaft are damaged and require replacement.

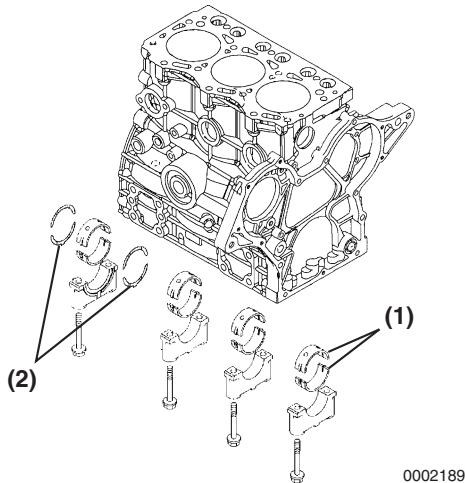

Figure 6-59

13. If necessary, remove the crankshaft gear (**Figure 6-60, (1)**) and key (**Figure 6-60, (2)**). If using a gear puller, be careful not to damage the threads in the end of the crankshaft.

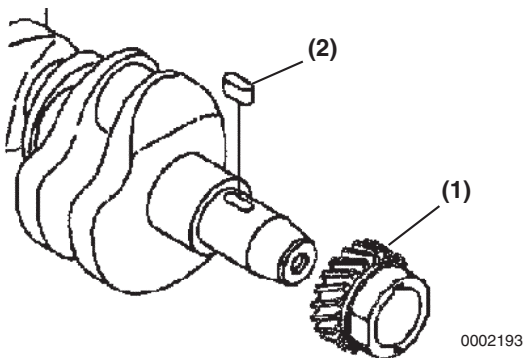

Figure 6-60

Inspection of Crankshaft and Camshaft Components

⚠ WARNING



FUME / BURN HAZARD!

- Always read and follow safety related precautions found on containers of hazardous substances like parts cleaners, primers, sealants and sealant removers.
- Failure to comply could result in death or serious injury.

0000014en

Thoroughly clean all components using a brush and appropriate solvent. Each part must be free of carbon, gasket material, metal filings and other debris.

Note: Record all measurements taken during inspection.

Replacement of Crankshaft Oil Seals

1. Remove the seal (**Figure 6-61, (2)**) from the gear case cover (**Figure 6-61, (1)**).
2. Apply a continuous bead of ThreeBond Liquid Gasket No. 1212, Yanmar Part No. 977770-01212 to the outside diameter of a new oil seal (**Figure 6-61, (2)**).
3. Install a new seal in the gear case cover with the lip facing in away from the crankshaft pulley. Apply lithium grease to the lip of the seal.

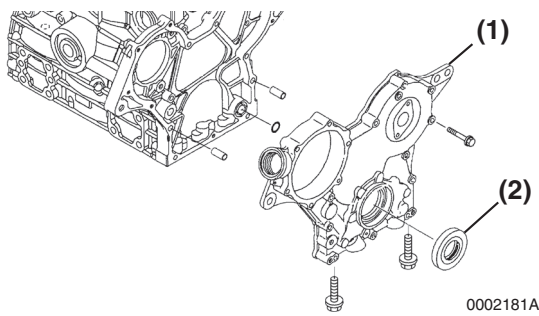

Figure 6-61

4. Remove the rear oil seal (Figure 6-62, (1)) from the flywheel housing (Figure 6-62, (2)).

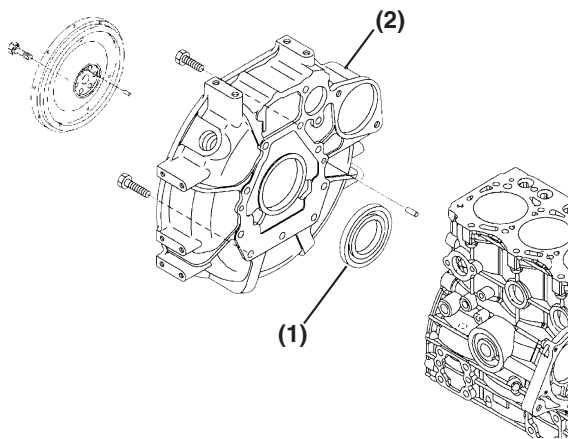

Figure 6-62

5. Apply a continuous bead of ThreeBond Liquid Gasket No. 1212, Yanmar Part No. 977770-01212 to the outside diameter of a new oil seal (Figure 6-62, (1)).
6. Install a new seal in the flywheel housing (Figure 6-62, (2)) with the lip facing in away from the flywheel. Apply lithium grease to the lip of the seal.

Crankshaft Bearing Oil Clearance

Oil clearance should be checked during disassembly to determine the extent of wear, and during assembly to ensure long engine life. The same procedure is done for both connecting rods and main bearings. See *Removal of Pistons* on page 6-42 or *Removal of Crankshaft* on page 6-44 for specific information.

Inspection of Cylinder Block

1. Ensure that oil passages are clear and unobstructed.
2. Check for discoloration or evidence of cracks. If a fracture is suspected, use the color check method or the MAGNAFLUX® method to determine if the cylinder block is fractured.
3. Measure cylinders for roundness, taper, and inspect for evidence of scoring. Consider honing, re-boring or replacing the cylinder block if the measurements are not within specification.
 - Take measurements at three places (Figure 6-63) (a, b, and c), and in two directions (d and e) in each cylinder. Collect and record the measurements. See *Cylinder Block* on page 6-13 for specifications.

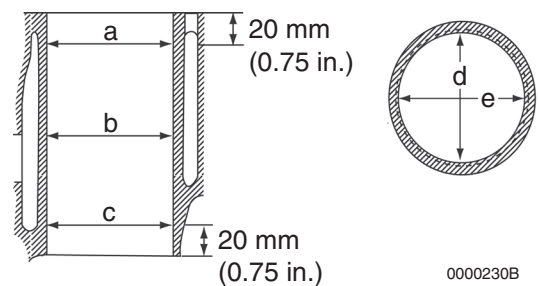

Figure 6-63

Roundness

Roundness can be calculated by subtracting the smaller measured value from the larger measured value of (d or e) at each measuring location (a, b, and c).

Taper

Taper can be calculated by subtracting the minimum measured value from the maximum measured value of locations (a, b, and c). Calculate along both the (d) axis and (e) axis and use the larger of the two calculations as the value to compare to the specifications.

Inspection of Pistons, Piston Rings and Wrist Pin

Notes:

- On an engine with low hours, the pistons, piston rings may be reused if they are found to be within specifications. The pistons and piston rings must be reinstalled in the same cylinders from which they were originally removed.
- On an engine with high hours, the pistons rings should be replaced and the cylinder honed (See *Honing and Boring on page 6-53*) or replaced. The piston should be replaced as necessary.

1. Clean piston ring grooves using a piston ring groove cleaning tool. Follow manufacturer's instructions for correct operation.
2. Wash the pistons in an appropriate solvent using a soft brush.
3. Visually inspect each piston for cracks. Pay particular attention to the ring lands between the piston ring grooves.
4. Measure the diameter of the piston skirt at 90° to the wrist pin bore as shown (Figure 6-64). Measurements must be taken at a specified distance (Figure 6-64, (1)) from the bottom of the piston, based on engine model. Record the measurements. See *Piston on page 6-10 for specifications*.

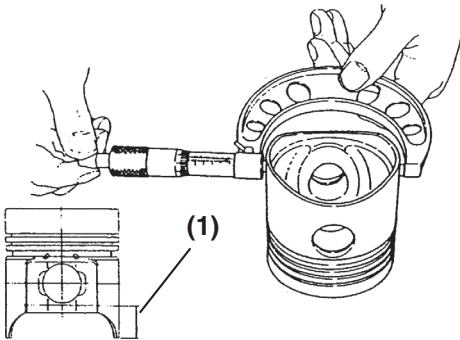

0000235

Figure 6-64

5. Subtract the piston measurement from the greatest measurement acquired during cylinder inspection (see *Inspection of Cylinder Block on page 6-47*) to obtain piston-to-cylinder clearance. Record the measurements. See *Piston on page 6-10 for specifications*.
6. Measure the diameter of the wrist pin bore on both sides of the piston (Figure 6-65). See *Piston on page 6-10 for specifications*. Record the measurements.

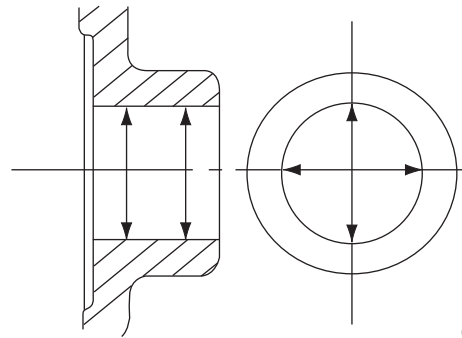

0000237

Figure 6-65

7. Measure the outside diameter of the wrist pin in three places and at 90° (Figure 6-66). See *Piston on page 6-10 for specifications*. Record the measurements.

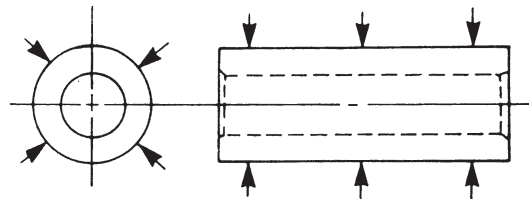

0001889

Figure 6-66

8. Using a micrometer, measure the thickness of each piston ring. See *Piston Ring on page 6-11 for specifications*. Record the measurements.

Notes:

- On an engine with low hours, the pistons, piston rings and cylinders may be reused if they are found to be within specifications.

- On an engine with high hours, the pistons rings should be replaced and the cylinder honed (See *Honing and Boring on page 6-53*) or replaced. The piston should be replaced as necessary.
9. Place each compression piston ring in the groove as shown (**Figure 6-67**). Use a feeler gauge to measure the clearance between the piston ring and the piston ring land. Record the measurements. See *Piston Ring on page 6-11 for specifications*. Replace the piston if not within specification.

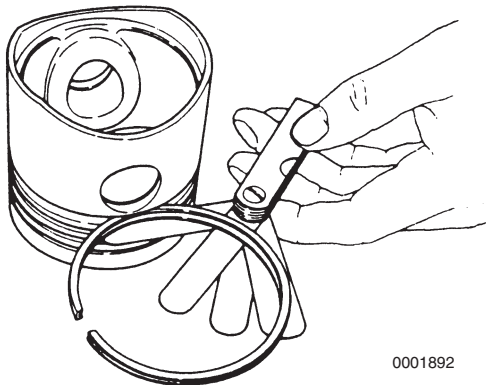

0001892

Figure 6-67

10. To measure piston ring end gap, insert each compression piston ring (**Figure 6-68, (1)**), one at a time, into the cylinder. Use a piston with the piston rings removed to slide the ring into the cylinder bore until it is approximately 1.18 in. (30 mm) (**Figure 6-68, (2)**) from the bottom of the bore. Remove the piston. Measure the end gap (**Figure 6-68, (3)**) of each piston ring. Record the measurements. See *Piston Ring on page 6-11 for specifications*.

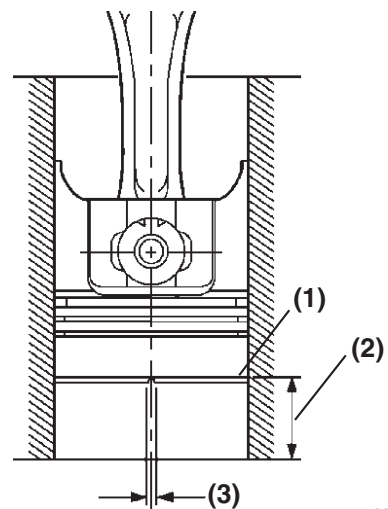

0001964

Figure 6-68

Note: Always check the piston ring end gap when installing new piston rings. See *Piston Ring on page 6-11 for specifications*. Use a piston ring end gap filing tool to adjust the piston ring end gap on new piston rings.

11. Repeat the above steps for each cylinder and piston assembly.

Inspection of Connecting Rod

1. Measure the wrist pin bushing bore using a bore gauge (**Figure 6-69, (1)**). Replace the bushing if not within specifications. If the bushing has been removed, measure the inside diameter of the connecting rod small end (**Figure 6-69, (2)**). Record the measurements. See *Connecting Rod on page 6-12 for specifications*.

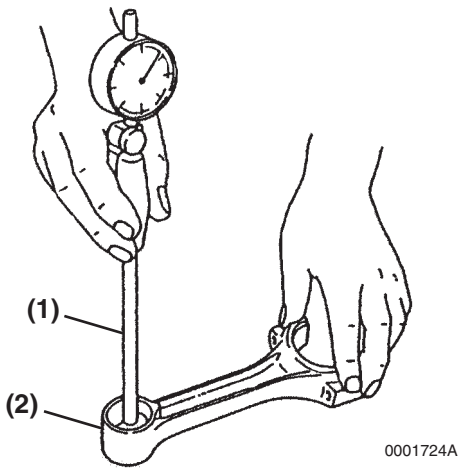

Figure 6-69

2. Measure the connecting rod twist (Figure 6-70, (1)) and bend (Figure 6-70, (2)) using a connecting rod alignment tool (Figure 6-71). Record the measurements. See *Connecting Rod* on page 6-12 for specifications.

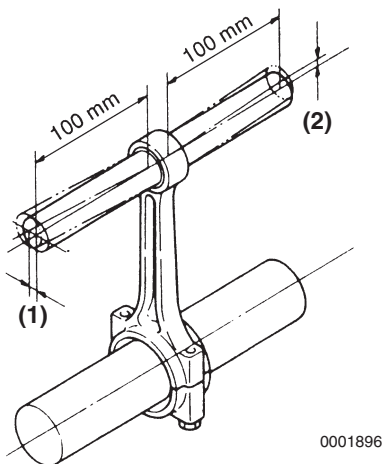

Figure 6-70

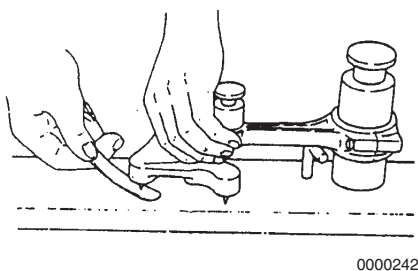

Figure 6-71

3. Place the connecting rod bearing inserts into the connecting rod and connecting rod cap. Install the rod cap and tighten the bolts to the specified torque.
4. Measure the inside diameter. Record the measurements. See *Crankshaft* on page 6-8 for specifications.

Inspection of Tappets

1. Inspect the tappet contact surfaces for abnormal wear (Figure 6-72, (1)). Normal wear will be even as shown in (Figure 6-72, (2)). Slight surface defects can be corrected using an oilstone.

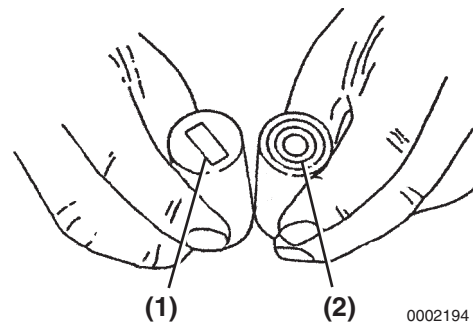

Figure 6-72

2. Measure the outside diameter of the tappet stem (Figure 6-73, (1)). Record the measurements. See *Tappet* on page 6-13 for the service limit.

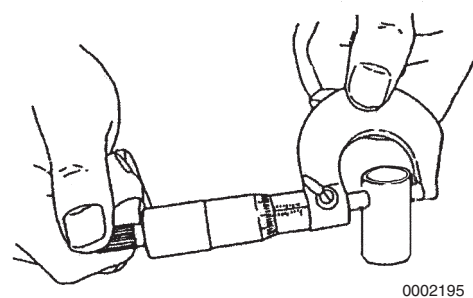

Figure 6-73

3. Measure the tappet bores in the cylinder block. Record the measurements. See *Tappet* on page 6-13 for the service limit.

Inspection of Crankshaft

1. Put the crankshaft end journals (**Figure 6-74, (4)**) on V-blocks.
2. Place a dial indicator (**Figure 6-74, (3)**) on a center main bearing surface.

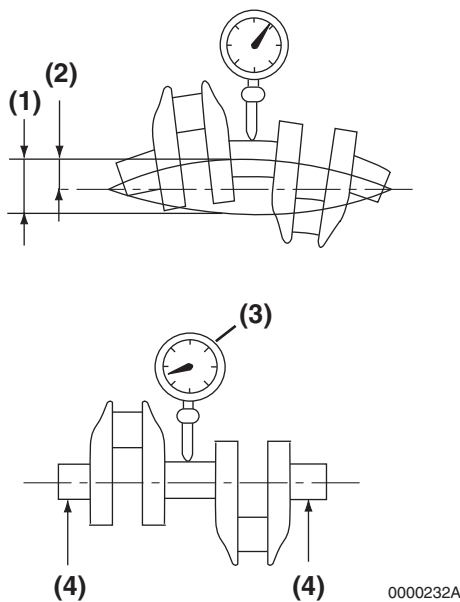

Figure 6-74

3. Rotate the crankshaft and observe runout. Record the measurements. *See Crankshaft on page 6-8 for specifications.*
4. Use the color check method or MAGNAFLUX to inspect the crankshaft for cracks. Replace the crankshaft if evidence of fractures is found.
5. Measure the outside diameter of each crankpin (**Figure 6-75, (2)**) and main bearing journal (**Figure 6-75, (1)**). *See Crankshaft on page 6-8 for specifications.* Take measurements at several places around each bearing surface. If not within specification, grind the journals and install undersize bearings, or replace the crankshaft. Record the measurements.

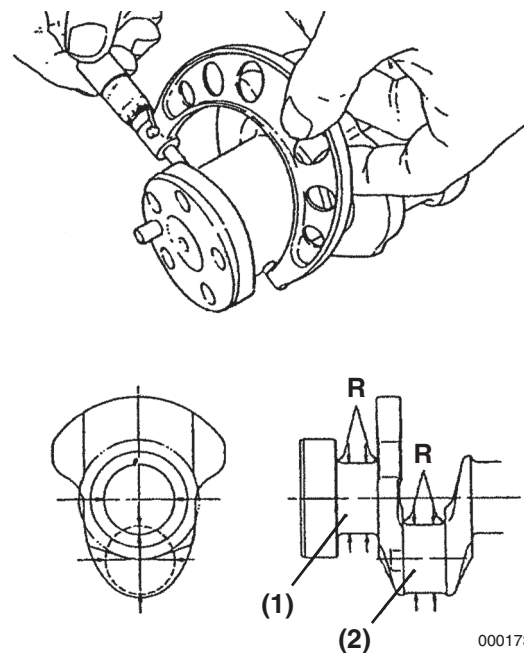

Figure 6-75

Reconditioning the Crankshaft

If any of the crankshaft journals do not meet the specifications, it may be possible to grind any or all of them to an undersize. The connecting rod bearings, main bearings, and thrust bearing inserts are available as 0.010 in. (0.25 mm) undersize. If the journals are ground undersize, the following finishing standards (**Figure 6-76**) must be adhered to:

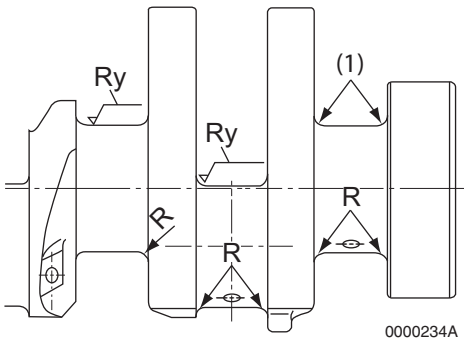

Figure 6-76

Item	Finishing Precision
Connecting Rod Journal Undersize Finished Size	1.6418 - 1.6422 in. (41.702 - 41.712 mm)
Main Bearing Journal Undersize Finished Size	1.8387 - 1.8391 in. (46.702 - 46.712 mm)
Journal Radius (R)	0.138 - 0.150 in. (3.5 - 3.8 mm)
Journal Face Finish (Ry)	0.8S (Super Polish)
Thrust Face Finish (1)	1.6

Inspection of Camshaft

1. Use V-blocks and a dial indicator to check camshaft bend (Figure 6-77). Place the indicator on the center bearing journal.

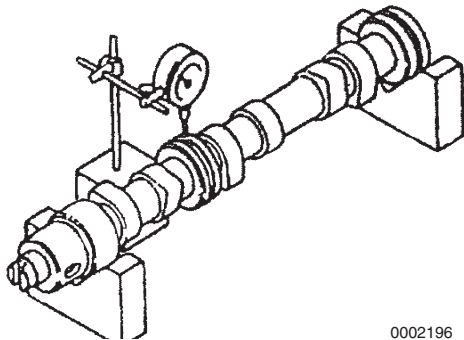

Figure 6-77

2. Rotate the camshaft and observe the runout. Record the measurements. See Camshaft on page 6-7 for specifications.
3. Measure the height of each lobe (Figure 6-78, (1)). Record the measurements. See Camshaft on page 6-7 for specifications.

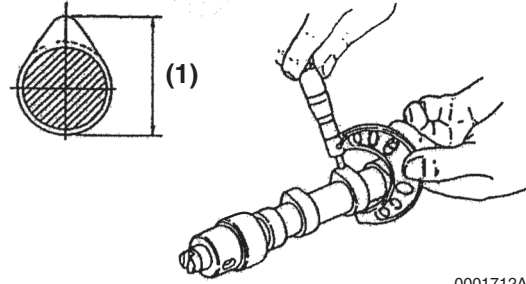

Figure 6-78

4. Measure the diameter of the gear end (Figure 6-79, (1)), intermediate (Figure 6-79, (2)), and flywheel end (Figure 6-79, (3)) bearing journals. Record the measurements. See Camshaft on page 6-7 for specifications.

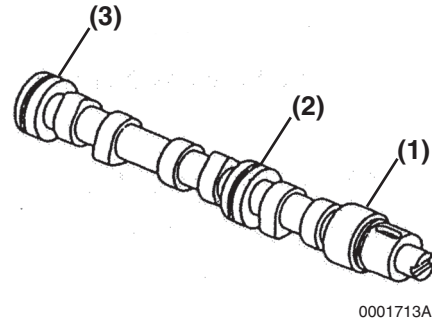

Figure 6-79

Inspection of Camshaft Bushing and Bores

1. Measure the I.D. of the front bushing and the remaining bores in the cylinder block. Record the measurements. *See Camshaft on page 6-7 for specifications.*

If the camshaft bushing is not within specification, replace using the appropriate service tool. If the remaining bores are not within specification, the cylinder block will require replacement as there are no bearing inserts used.

Inspection of Idler Gear and Shaft

1. Measure the outside diameter (**Figure 6-80, (1)**) of the idler gear shaft (**Figure 6-80, (2)**). Record the measurements. *See Idler Gear Shaft and Bushing on page 6-8 for specifications.*
2. Measure the inside diameter (**Figure 6-80, (3)**) of the idler gear bushing (**Figure 6-80, (4)**). Record the measurements. *See Idler Gear Shaft and Bushing on page 6-8 for specifications.*

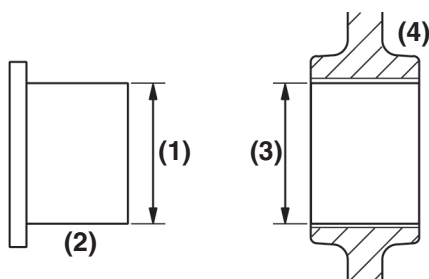

Figure 6-80

Honing and Boring

Pistons must move freely in the cylinders while maintaining adequate compression and oil sealing. If the cylinder walls are scuffed, scored, out-of-round, or tapered beyond specifications, rebore and hone to restore cylinders to usable condition. Slight imperfections can be corrected by honing alone.

1. **Boring** - Significant cylinder damage may be corrected by boring the cylinder to an oversize dimension. Refer to the appropriate parts catalog for available oversize pistons and piston rings.
 - Boring a cylinder should always be done in a properly equipped machine shop.
 - A bored cylinder should always be finished with a hone to properly prepare the cylinder surface so the new piston rings will seat properly.
 - After the cylinder has been bored and honed, install the appropriate oversize pistons and piston rings.
2. **Honing** - Minor cylinder imperfections may be corrected by using a rigid cylinder hone (**Figure 6-82, (1)**). Be sure not to exceed the maximum cylinder bore specification.

Deglazing - A used cylinder that did not require boring or honing, should always be deglazed with a ball hone (**Figure 6-82, (2)**) before installing new piston rings. This will properly prepare the cylinder surface to allow new piston rings to seat properly.

Note: When honing a cylinder, with either a ridged hone or a ball hone (**Figure 6-81, (1)**), move the rotating hone up and down in the cylinder bore to accomplish a 30° to 40° crosshatch pattern (**Figure 6-81**). This will provide the ideal surface for the proper seating of new piston rings.

CAUTION

Do not allow the honing tool to operate in one position for any length of time. Damage to the cylinder wall will occur. Keep the tool in constant up-and-down motion.

0000090en

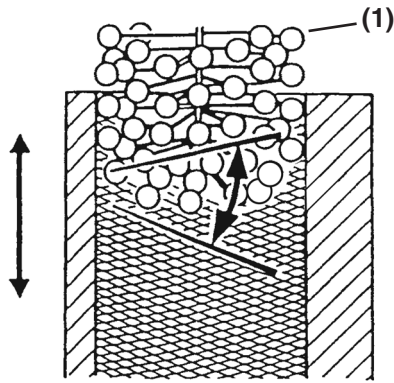

0000248A

Figure 6-81

- Use a 50:50 mixture of diesel fuel and engine oil as a honing fluid.
- Use a 300-grit hone at 300 - 1200 rpm (**Figure 6-82**).

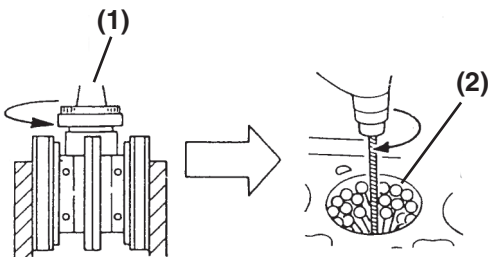

0000249B

Figure 6-82**IMPORTANT**

Solvents will not adequately remove honing residue, resulting in premature piston and ring wear. Always wash cylinders using hot, soapy water.

- When honing is completed, wash the cylinder block with hot water and soap. The cylinder wall is adequately cleaned when a white rag wiped in cylinder comes out clean. Use brushes to clean all passages and crevices. Rinse with hot water and dry with compressed air. Apply clean engine oil to all steel surfaces to prevent rusting.

Reassembly of Crankshaft and Piston Components

Notes:

- Proceed slowly. Make no forced assemblies unless a pressing operation is called for. All parts must be perfectly clean and lightly lubricated when assembled.
- Use new gaskets, seals and O-rings during assembly.
- Liberally apply clean engine oil to all internal parts during assembly.
- All fasteners should be tightened to a given torque. If a special torque is not provided in the *Special Torque Chart on page 6-14*, tighten to standard torque specifications. See *Tightening Torques for Standard Bolts and Nuts on page 4-24*.

Reassembly of Pistons

1. Select the parts needed to assemble the piston and connecting rod for one cylinder.
2. If removed, install a new wrist pin bushing (**Figure 6-83, (7)**) using a press and the appropriate service tool. Be sure to align the oil holes.

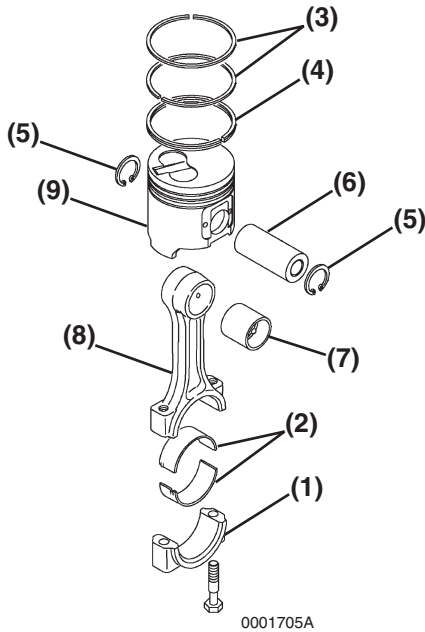

Figure 6-83

3. Reinstall one circlip (**Figure 6-83, (5)**) into the piston. Ensure the circlip is securely seated in the groove.

IMPORTANT

*The piston and connecting rod must be assembled with the correct orientation. When correctly assembled, the piston identification mark (**Figure 6-84, (1)**) stamped into the top of the piston will be on the opposite side of the connecting rod as the match marks (**Figure 6-84, (3)**) stamped into the connecting rod and connecting rod cap. When reinstalled in the cylinder, the embossed mark (**Figure 6-84, (2)**) cast into the beam of connecting rod will face the flywheel end of the engine.*

Note: The actual appearance of the match marks will vary but they will always be in the same locations.

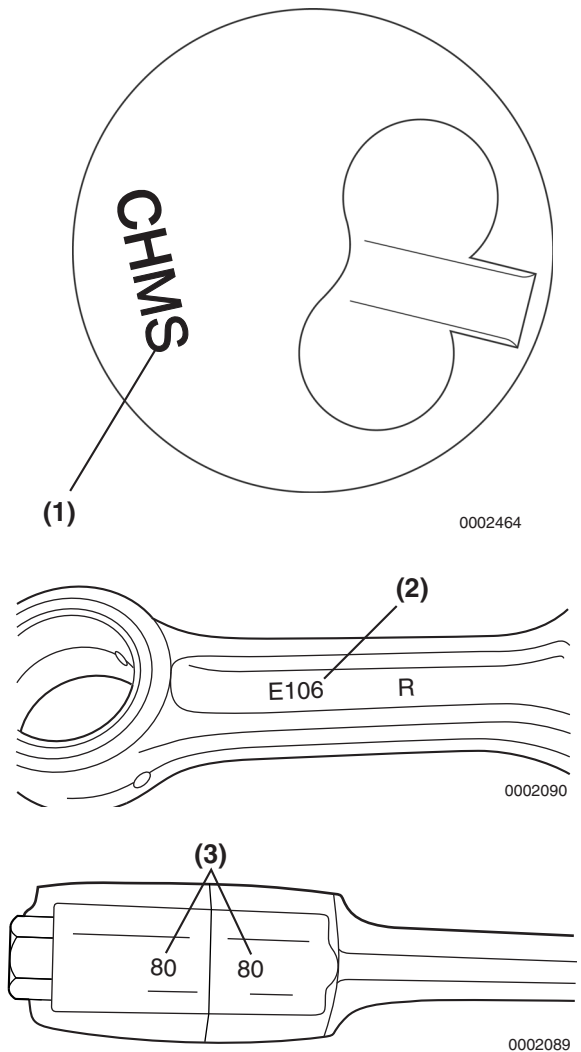
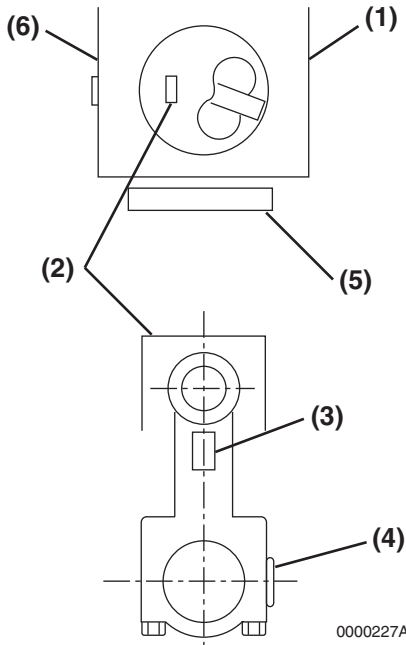

Figure 6-84

4. Place the connecting rod into the piston. The match marks (**Figure 6-85, (4)**) on the connecting rod and cap must be on the opposite side as the piston identification mark (**Figure 6-85, (2)**) on the top of the piston.



- 1 – Fuel Injection Pump Side of Engine
- 2 – Piston Identification Mark
- 3 – Embossed Mark on Connecting Rod
- 4 – Connecting Rod and Cap Match Marks
- 5 – Flywheel End of Engine
- 6 – Camshaft Side of Engine

Figure 6-85

5. Lubricate and install the wrist pin (Figure 6-86, (6)) through the piston and connecting rod.
6. Reinstall the second circlip (Figure 6-86, (5)) and ensure it is securely seated in the groove.

Note: If installing new piston rings the end gap must be checked and adjusted as necessary. See *Inspection of Pistons, Piston Rings and Wrist Pin* on page 6-48. Use a piston ring end gap filing tool to adjust the piston ring end gap on new piston rings.

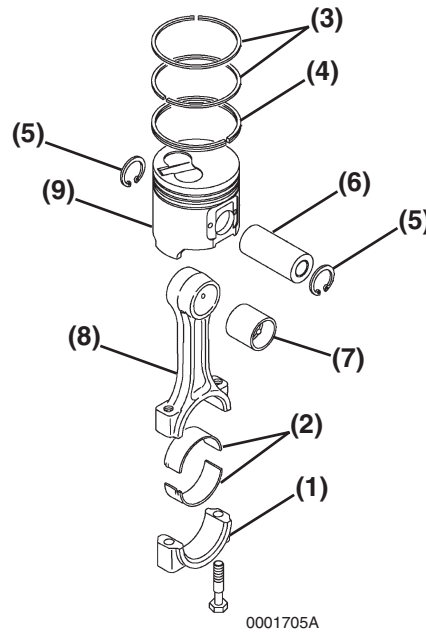

Figure 6-86

Note: Reinstall the top and second piston rings with the stamped “makers mark” (Figure 6-87, (1)) facing the top of the piston. The “makers mark” may vary in appearance but will always be located on the top surface of the piston ring adjacent to the piston ring gap. The oil ring and oil ring expander can be installed either side up.

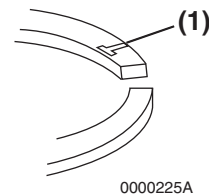

Figure 6-87

IMPORTANT

Always use a piston ring expander when installing piston rings. Never attempt to install piston rings by hand.

7. Reinstall the oil ring expander
(**Figure 6-88, (4)**). Install the oil ring
(**Figure 6-88, (3)**) with the end gap at 180° from
the expander end gap.
8. Reinstall the second compression ring
(**Figure 6-88, (2)**). This ring is identified by its
dark color and tapered face profile.
9. Reinstall the top compression ring
(**Figure 6-88, (1)**). This ring is identified by its
silver color and barrel-shaped face profile.

IMPORTANT

The oil ring expander (**Figure 6-88, (4)**) end gap must be located 180° from the oil ring (**Figure 6-88, (3)**) end gap.

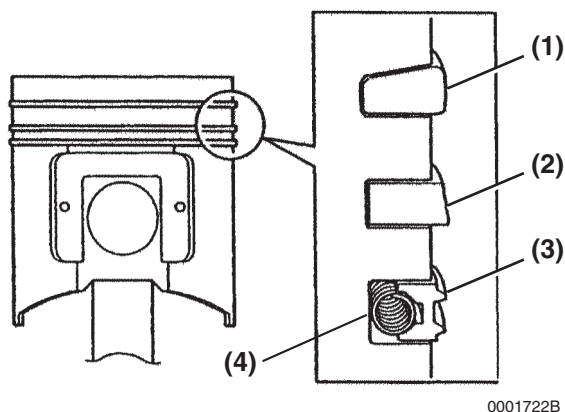

0001722B

Figure 6-88

10. Stagger the piston ring end gaps at 120° intervals (**Figure 6-89, (1, 2, and 3)**). Do not position the top piston ring end gap in line with the wrist pin.

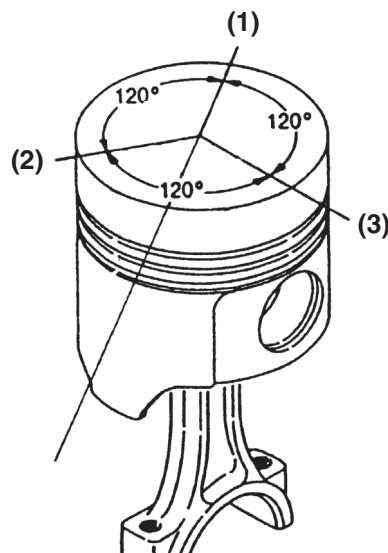

- 1 – Top Compression Ring End Gap
- 2 – Second Compression Ring End Gap
- 3 – Oil Ring End Gap

Figure 6-89

Installation of Crankshaft

1. If removed, reinstall the key and timing gear on crankshaft.
2. Install new bearing inserts (**Figure 6-90, (1)**) and thrust bearing (**Figure 6-90, (2)**) in the cylinder block and main bearing caps. Be sure the oil holes in the upper bearing shells align with the oil ports in the cylinder block. Apply a liberal coat of clean engine oil to the bearings and crankshaft journals.

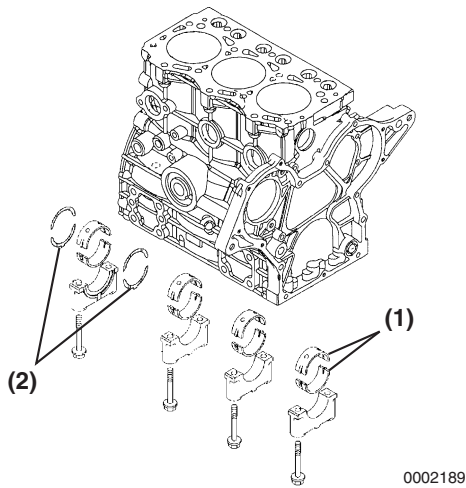

Figure 6-90

3. Install the crankshaft in the engine.

IMPORTANT

The main bearing caps are numbered and have arrows for proper positioning. The No. 1 cap is at the flywheel end. The arrows point toward the flywheel end of the engine.

4. Reinstall the main bearing caps.
5. Apply a light coat of clean engine oil to the bearing cap bolts and tighten the bolts to the specified torque in two stages (1/2 then full torque). See *Special Torque Chart* on page 6-14.
6. Rotate the crankshaft to ensure it turns freely.
7. Apply ThreeBond Liquid Gasket No. 1212, Yanmar Part No. 977770-01212 to the mounting flange of the flywheel housing (**Figure 6-91, (2)**).
8. Align the flywheel housing with the two dowel pins (**Figure 6-91, (3)**).
9. Reinstall flywheel housing and seal assembly.
10. Reinstall the flywheel (**Figure 6-91, (1)**) and tighten the bolts to the specified torque. See *Special Torque Chart* on page 6-14.

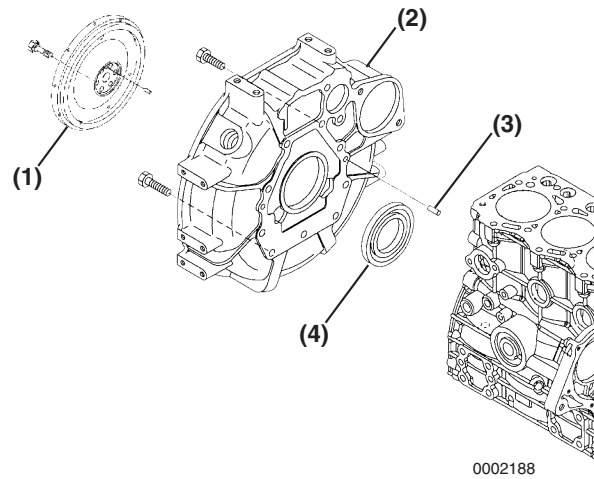
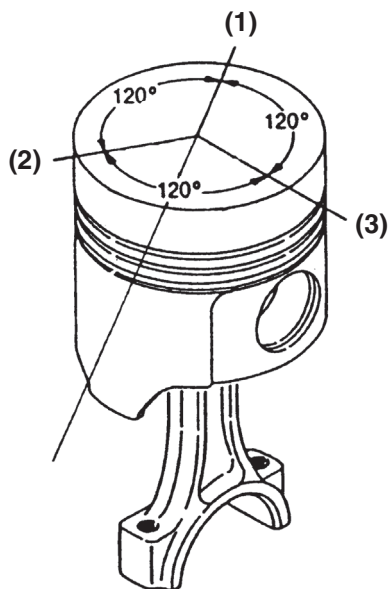

Figure 6-91

Installation of Pistons**IMPORTANT**

Do not allow the connecting rod to contact the crankshaft journal during piston installation. Damage to the crankshaft bearing journal may result.

1. Lubricate piston, piston rings, and cylinder with clean engine oil or assembly lubricant.
2. Rotate the crankshaft so the crankpin for the piston being installed is near bottom dead center.



0000226A

- 1 – Top Compression Ring End Gap
- 2 – Second Compression Ring End Gap
- 3 – Oil Ring End Gap

Figure 6-92

IMPORTANT

Ensure piston ring gaps are located correctly (**Figure 6-92**).

3. Using a piston ring compressor, compress the piston rings.

IMPORTANT

The piston and connecting rod must be reinstalled with the correct orientation. When installed correctly, the identification mark (**Figure 6-93, (2)**) stamped into the top of the piston will be on the same side of the engine as the fuel injection pump (**Figure 6-93, (1)**) and the embossed mark (**Figure 6-93, (3)**) cast into the connecting rod beam will face the flywheel end of the engine (**Figure 6-93, (5)**).

4. Carefully reinstall the piston and rod assembly. Be sure the match marks (**Figure 6-93, (4)**) stamped into the connecting rod and cap are facing the fuel injection pump side of the cylinder block, and the piston identification mark (**Figure 6-93, (2)**) stamped into the piston top is facing the camshaft side (**Figure 6-93, (6)**). The embossed mark cast into the connecting rod beam (**Figure 6-93, (3)**) will be facing the flywheel end of the engine (**Figure 6-93, (5)**).

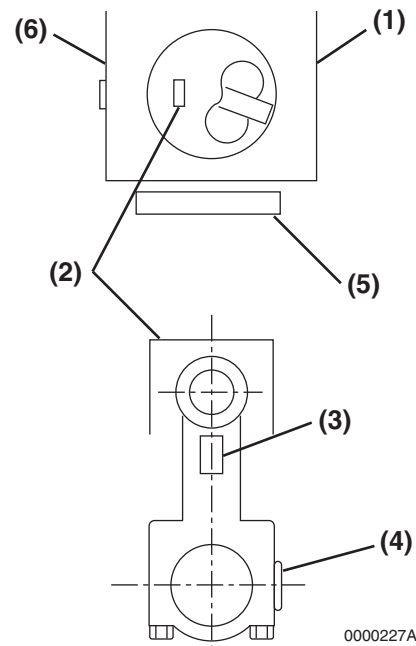

0000227A

- 1 – Fuel Injection Pump Side of Engine
- 2 – Piston Identification Mark
- 3 – Embossed Mark on Connecting Rod
- 4 – Rod and Cap Match Marks
- 5 – Flywheel End of Engine
- 6 – Camshaft Side of Engine

Figure 6-93

5. Reinstall the bearing inserts (**Figure 6-94, (1)**) in the connecting rod and cap.
6. Apply a liberal coat of clean engine oil to the bearing inserts and crankshaft journal.

7. Apply a light coat of clean engine oil to the rod cap bolts. Reinstall the connecting rod cap (**Figure 6-94, (2)**). Tighten the connecting rod bolts to the specified torque in two stages (1/2 then full torque). See *Special Torque Chart* on page 6-14.

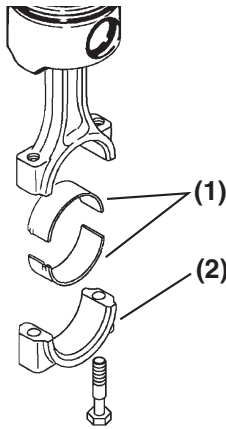

0001965

Figure 6-94

8. Reinstall the remaining pistons in their respective cylinders.

Reassembly of Camshaft and Timing Components

Installation of Gear Case

1. If removed, install a new camshaft bushing (**Figure 6-95, (3)**) using the appropriate service tool.
2. Apply a continuous bead of ThreeBond Liquid Gasket No. 1212, Yanmar Part No. 977770-01212 to the mounting area of the gear case. Be sure to circle each bolt hole.
3. Reinstall dowels and new O-rings (**Figure 6-95, (2)**).

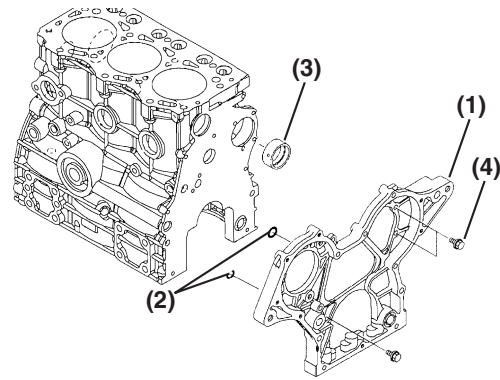

0002187

Figure 6-95

4. Reinstall the gear case (**Figure 6-95, (1)**). Tighten the bolts (**Figure 6-95, (4)**) to the specified torque.

Installation of Camshaft

Note: The gear housing must be installed prior to reinstalling the camshaft. See *Installation of Gear Case* on page 6-60.

1. If removed, reinstall the camshaft end plate (**Figure 6-96, (1)**), key, and camshaft gear (**Figure 6-96, (4)**) onto the camshaft using a press.
 - Heat the gear to 356 - 392°F (180 - 200°C) and press onto the end of the camshaft.
2. Lubricate the camshaft (**Figure 6-96, (2)**) with clean engine oil or assembly lube. Slowly insert the camshaft through the front of the engine.
3. Reinstall and tighten the cap screws (**Figure 6-96, (3)**).

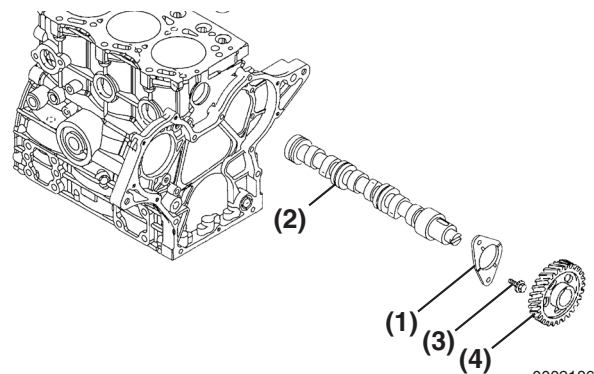

0002186

Figure 6-96

4. Lubricate the camshaft lobes and tappets with clean oil or assembly lube. Reinstall the tappets in their respective locations in the cylinder block. Push the tappets fully into the tappet bores until they make solid contact with the camshaft.
5. If removed, reinstall the fuel injection pump. Adjust the fuel injection timing after installation. *See Checking and Adjusting Fuel Injection Timing on page 7-19.*

Installation of Timing Gears

1. Set No. 1 piston to top dead center.
2. Rotate the camshaft until mark **(Figure 6-98, (C))** is approximately at the 9 o'clock position.
3. Lubricate the idler gear **(Figure 6-97, (3))**, bushing **(Figure 6-97, (2))** and idler gear shaft **(Figure 6-97, (1))** with clean engine oil or assembly lube.

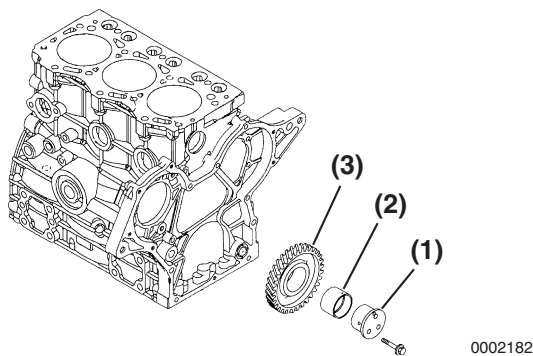
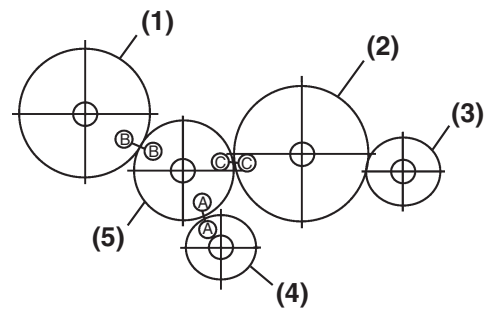

Figure 6-97

4. Align the timing gears as shown in **Figure 6-98**.
5. Reinstall the idler gear and idler gear shaft. Be sure the oil hole in the bushing is facing toward the top of the engine.
6. Ensure all three timing marks **(Figure 6-98, (A, B, and C))** are aligned.



0002190

- 1 – Fuel Injection Pump Gear
- 2 – Camshaft Gear
- 3 – Optional Accessory Drive Gear
- 4 – Crankshaft Gear
- 5 – Idler Gear

Figure 6-98

7. When all gears are properly aligned, tighten the idler gear retaining bolts to specified torque. *See Special Torque Chart on page 6-14 for specifications.*

Installation of Gear Case Cover

1. Apply a continuous bead of ThreeBond Liquid Gasket No. 1212, Yanmar Part No. 977770-01212 to the mounting area of the gear case cover **(Figure 6-99, (1))**. Be sure to circle the bolt holes.

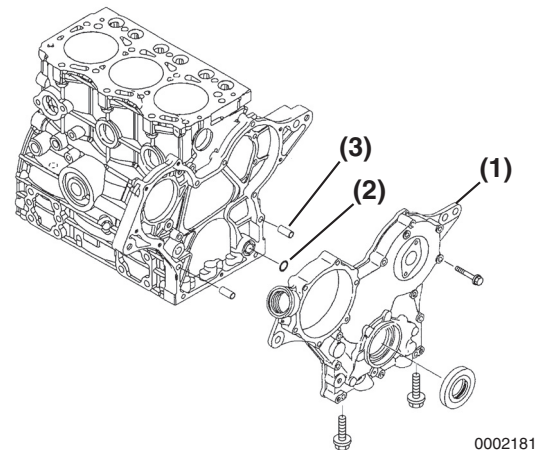

0002181

Figure 6-99

2. Reinstall the dowels **(Figure 6-99, (3))** and a new O-ring **(Figure 6-99, (2))**.

IMPORTANT

Be sure to align the flats on the oil pump with the flats on the crankshaft gear.

3. Reinstall the timing gear case cover.
4. Reinstall and tighten the gear case cover bolts.
5. Reinstall the crankshaft pulley.
6. Reinstall the washer and bolt. Tighten to the specified torque. See *Special Torque Chart* on page 6-14 for specifications.

Installation of Oil Pan

1. Reinstall the oil pickup tube (**Figure 6-100, (1)**) and a new O-ring (**Figure 6-100, (2)**).

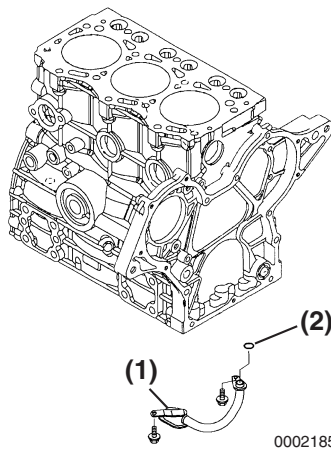
**Figure 6-100**

2. Apply a continuous bead of ThreeBond Liquid Gasket No. 1212, Yanmar Part No. 977770-01212 to the mounting surface of the oil pan (**Figure 6-101, (2)**) and crankcase extension (if equipped) (**Figure 6-101, (1)**). Be sure to circle each bolt hole.
3. If equipped, reinstall the crankcase extension (**Figure 6-101, (1)**). Reinstall the oil pan and tighten the bolts securely.

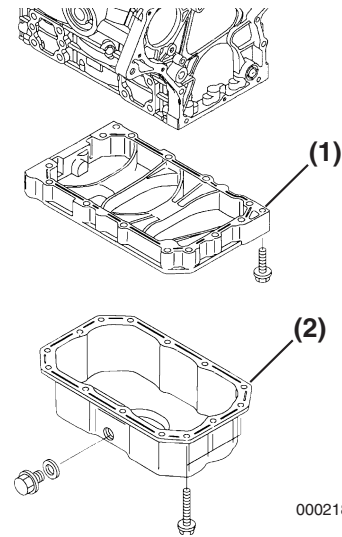
**Figure 6-101****Final Assembly of Engine**

1. Reinstall the starter motor.
2. Reinstall the cylinder head. See *Reassembly of Cylinder Head* on page 6-31.
3. Reinstall the engine in the machine.
4. Reconnect the fuel and coolant lines.
5. Reinstall the alternator.
6. Reconnect and adjust the throttle cable.
7. Reconnect all electrical connections.
8. Fill the engine with oil and coolant.
9. Reconnect the battery cables, negative (-) cable last.

Section 7

FUEL SYSTEM

	Page
Before You Begin Servicing	7-3
Introduction.....	7-5
Fuel Injection Pump.....	7-5
Stop Solenoid	7-6
Fuel System Specifications	7-7
Special Torque Chart.....	7-7
Test and Adjustment Specifications	7-7
Special Service Tools.....	7-8
Measuring Instruments.....	7-8
Fuel System Diagram.....	7-9
Fuel System Components	7-10
Fuel Injection Lines	7-11
Removal of High-Pressure Fuel Injection Lines	7-11
Installation of High-Pressure Fuel Injection Lines	7-12
Removal of Fuel Return Line.....	7-12
Installation of Fuel Return Line.....	7-13
Fuel Injection Pump.....	7-13
Removal of Fuel Injection Pump.....	7-13
Installation of Fuel Injection Pump.....	7-16
Checking and Adjusting Fuel Injection Timing	7-19
Checking Fuel Injection Timing	7-19
Adjusting Fuel Injection Timing.....	7-23
Fuel Injectors.....	7-23
Removal of Fuel Injectors.....	7-23
Testing of Fuel Injectors	7-24

FUEL SYSTEM

Disassembly and Inspection of Fuel Injectors	7-27
Adjusting Fuel Injector Pressure	7-28
Reassembly of Fuel Injectors	7-29
Installation of the Fuel Injectors.....	7-29

BEFORE YOU BEGIN SERVICING

⚠ WARNING



ENTANGLEMENT HAZARD!

- Stop the engine before you begin to service it.
- NEVER leave the key in the key switch when you are servicing the engine. Someone may accidentally start the engine and not realize you are servicing it. This could result in a serious injury.
- If you must service the engine while it is operating, remove all jewelry, tie back long hair, and keep your hands, other body parts and clothing away from moving / rotating parts.
- Failure to comply could result in death or serious injury.

0000010en

⚠ WARNING



FUME / BURN HAZARD!

- Always read and follow safety related precautions found on containers of hazardous substances like parts cleaners, primers, sealants and sealant removers.
- Failure to comply could result in death or serious injury.

0000014en

⚠ WARNING



To prevent possible eye injury, always wear **SAFETY GLASSES** while servicing the engine.

0000013en

⚠ CAUTION



FLYING OBJECT HAZARD!

- ALWAYS wear eye protection when servicing the engine and when using compressed air or high-pressure water. Dust, flying debris, compressed air, pressurized water or steam may injure your eyes.
- Failure to comply may result in minor or moderate injury.

0000003en

⚠ CAUTION



PINCH HAZARD!

Carefully rotate the alternator toward the cylinder block while loosening the V-belt. Failure to comply may result in minor or moderate injury.

0000014en

CAUTION

- **NEVER** remove or attempt to remove the tamper-proof devices from the full-load fuel adjusting screw or the high-speed throttle limit screw on the fuel injection pump and governor assembly. These adjustments have been made at the factory to meet all applicable emissions regulations and then sealed.
- **NEVER** attempt to make any adjustments to these sealed adjustment screws. If adjustments are required, they can be made only by a qualified fuel injection shop that will ensure the injection pump continues to meet all applicable emissions regulations and then replace the tamper-proof seals.
- Tampering with or removing these devices may void the “Yanmar Limited Warranty.”

0000146en

CAUTION

Never use a steel wire brush to clean fuel injectors. Damage to the nozzle and other components is likely to result.

0000172en

CAUTION

Do not loosen or remove the four bolts retaining the fuel injection pump drive gear to the fuel injection pump hub. Do not disassemble the fuel injection pump drive gear from the hub. Correct fuel injection timing will be very difficult or impossible to achieve.

0000031en

CAUTION

Remove or install the high-pressure fuel injection lines as an assembly whenever possible. Disassembling the high-pressure fuel injection lines from the retainers or bending any of the fuel lines will make it difficult to reinstall the fuel lines.

0000047en

CAUTION

After marking the position of the pump drive gear, do not rotate the engine crankshaft. Rotating the crankshaft will cause the fuel injection pump to become misaligned.

0000048en

CAUTION

Do not rotate the crankshaft with the injection pump removed.

0000083en

CAUTION

The fuel return line is a one-piece assembly. Use care not to bend or twist the fuel return line.

0000171en

INTRODUCTION

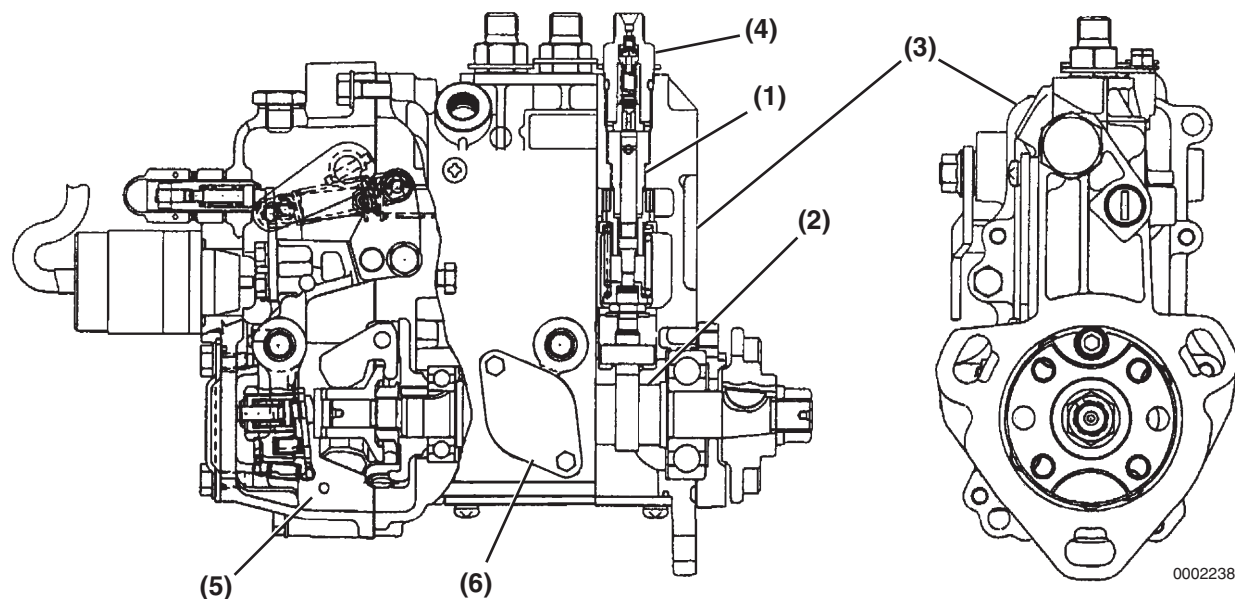

Figure 7-1

This section of the *Service Manual* describes the procedures necessary to remove, install, and time the ML fuel injection pump and its associated system components. This fuel injection pump is representative of the fuel injection pumps used on other TNV IDI model engines.

Fuel Injection Pump

Note: If the ML fuel injection pump itself requires servicing, it must be taken to an authorized Yanmar FIE (Fuel Injection Equipment) repair facility.

The following describes the features of the ML fuel injection pump, manufactured by Yanmar.

The fuel injection pump is a very important component of the engine. It is capable of making very precise fuel delivery adjustments according to the varied loads applied to the engine.

All of the fuel injection pump components are very precisely machined. It is extremely important to follow good service practices and maintain cleanliness when servicing the fuel injection pump.

The Yanmar ML Fuel Injection Pump is an in-line type pump which consists of a fuel supply plunger (**Figure 7-1, (1)**) for each cylinder, a camshaft (**Figure 7-1, (2)**), and a pump housing (**Figure 7-1, (3)**). A delivery valve (**Figure 7-1, (4)**) connects to a high-pressure fuel line for each cylinder. The fuel injection pump housing contains a governor (**Figure 7-1, (5)**).

Fuel from the fuel tank to the fuel injection pump is delivered by a low-pressure electric fuel pump. On a few special models, a mechanical fuel pump is used instead of an electric pump. The mechanical fuel pump is mounted to the fuel injection pump housing in place of the cover plate (**Figure 7-1, (6)**).

Fuel to be injected into the cylinders is pressurized by the up and down motion of each camshaft-driven plunger, and is then supplied by the high-pressure fuel lines to the respective fuel injector.

CAUTION

- **NEVER** remove or attempt to remove the tamper-proof devices from the full-load fuel adjusting screw or the high-speed throttle limit screw on the fuel injection pump and governor assembly. These adjustments have been made at the factory to meet all applicable emissions regulations and then sealed.
- **NEVER** attempt to make any adjustments to these sealed adjustment screws. If adjustments are required, they can be made only by a qualified fuel injection shop that will ensure the injection pump continues to meet all applicable emissions regulations and then replace the tamper-proof seals.
- **Tampering with or removing these devices may void the “Yanmar Limited Warranty.”**

0000146en

The fuel injector is essentially a spring-loaded valve. When fuel pressure from the fuel injection pump reaches a pre-determined level, the pintle (valve) is forced off its seat and fuel is atomized as it passes between the pintle and seat. The timing and quantity of the fuel injected into the cylinder is controlled by the fuel injection pump and governor assembly.

Stop Solenoid

The ML fuel injection pumps are equipped with a stop solenoid that controls the fuel flow inside the fuel injection pump.

With the starter switch in the OFF position, no current flows to the stop solenoid and the solenoid plunger is extended holding the fuel injection pump fuel rack in the “closed” position and not allowing fuel to flow through the injection pump and to the engine.

When the starter switch is turned to the start position, the “pull coil” (36.5 Amp draw / white wire) inside the solenoid is activated and pulls the solenoid plunger into the solenoid. This releases the fuel injection pump fuel rack, allowing fuel to flow through the injection pump and allowing the engine to start and run.

When the starter switch is returned to the ON or RUN position, the “pull coil” no longer receives current and the “hold coil” (0.5 Amp draw / red wire) inside the solenoid is activated. The “hold coil” holds the solenoid plunger in the RUN position, allowing fuel to continue flowing and the engine to continue running.

To stop the engine, the key switch is turned to the OFF position. Current no longer flows to the stop solenoid “hold coil,” and the solenoid plunger extends and moves the injection pump fuel rack to the “closed” position, and shutting off the fuel flow and stopping the engine.

Failure of the stop solenoid could result in the engine not starting, the engine stopping suddenly or the engine continuing to run with the key switch returned to the ON or RUN position, or the engine failing to stop when the key switch is turned to the OFF position. Use a VOA multimeter or continuity light to check for a good ground and 12V at the stop solenoid in the correct sequence.

FUEL SYSTEM SPECIFICATIONS

Special Torque Chart

Component	Tightening Torque	Lubricating Oil Application (Thread Portion and Seat Surface)
Fuel Injector	36.1 - 43.5 ft·lb (49 - 59 N·m; 5.0 - 60 kgf·m)	Not Applied
Fuel Pump Drive Gear Nut	44 - 51 ft·lb (59 - 69 N·m; 6 - 7 kgf·m)	Not Applied
High -Pressure Fuel Injection Line Nuts	22 - 25 ft·lb (29 - 34 N·m; 3.0 - 3.5 kgf·m)	Not Applied
Fuel Return Line Nuts	18 - 24 ft·lb (24 - 33 N·m; 2.5 - 3.3 kgf·m)	Not Applied
Fuel Injection Pump Mounting Nuts	17 - 21 ft·lb (23 - 28 N·m; 2.3 - 2.9 kgf·m)	Not Applied
Fuel Injector Nozzle Case Nut	21.4 - 36.1 ft·lb (29 - 49 N·m; 3.0 - 5.0 kgf·m)	Not Applied

Test and Adjustment Specifications

Fuel Injector Pressure	Fuel Injection Timing
1784 - 1929 psi (12.3 - 13.3 MPa; 125 - 136 kgf/cm ²)	<i>See Checking and Adjusting Fuel Injection Timing on page 7-19</i>

Note: Fuel injector pressures given are for used parts. New injectors (5 hours operation or less) will read approximately 72.5 psi (0.5 MPa; 5 kgf/cm²) higher.

SPECIAL SERVICE TOOLS

Note: Tools not having Yanmar part numbers must be acquired locally.

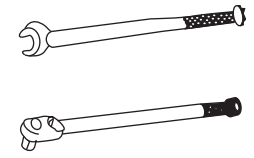
No.	Tool Name	Application	Illustration
1	Torque Wrench (Locally Available)	For tightening nuts and bolts to the specified torque	 0000840

MEASURING INSTRUMENTS

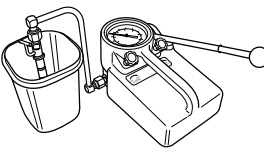
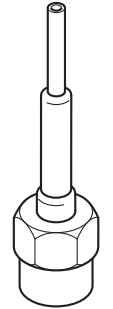
No.	Instrument Name	Application	Illustration
1	Fuel Injector Tester (Locally Available)	For observing injection spray pattern of fuel injection nozzle and measuring injection pressure	
2	"Spill-Timing" Tool (Shop Fabricated)*	Used to set fuel injection timing	

* Make from a short piece of the end of a high-pressure fuel line, a high-pressure fuel line nut, and a short piece of clear plastic tubing (a thin nozzle from an aerosol spray can works well). Drill out the end of the fuel line to accept the nozzle. Use a small amount of silicone sealant to seal the nozzle into the fuel line.

FUEL SYSTEM DIAGRAM

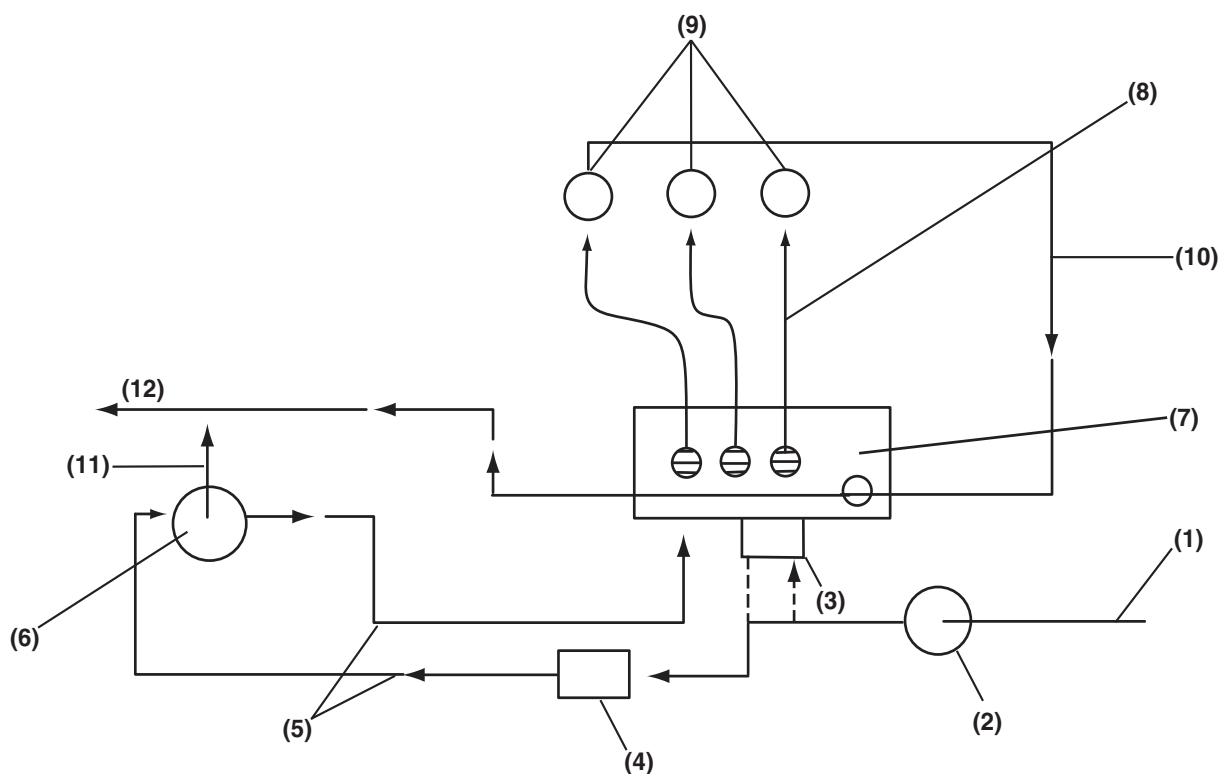

0001058A

Figure 7-2

- | | |
|---|--|
| 1 – Diesel Fuel Supply | 6 – Fuel Filter |
| 2 – Fuel Filter / Water Separator | 7 – Fuel Injection Pump |
| 3 – Mechanical Fuel Pump (Used in place of the electric fuel pump on some models) | 8 – High-Pressure Fuel Injection Lines |
| 4 – Electric Fuel Pump (Used on models without mechanical fuel pump) | 9 – Fuel Injectors |
| 5 – Low-Pressure Fuel Supply Lines | 10 – Fuel Return from Fuel Injectors |
| | 11 – Air Bleed Orifice |
| | 12 – Fuel Return to Tank |

FUEL SYSTEM COMPONENTS

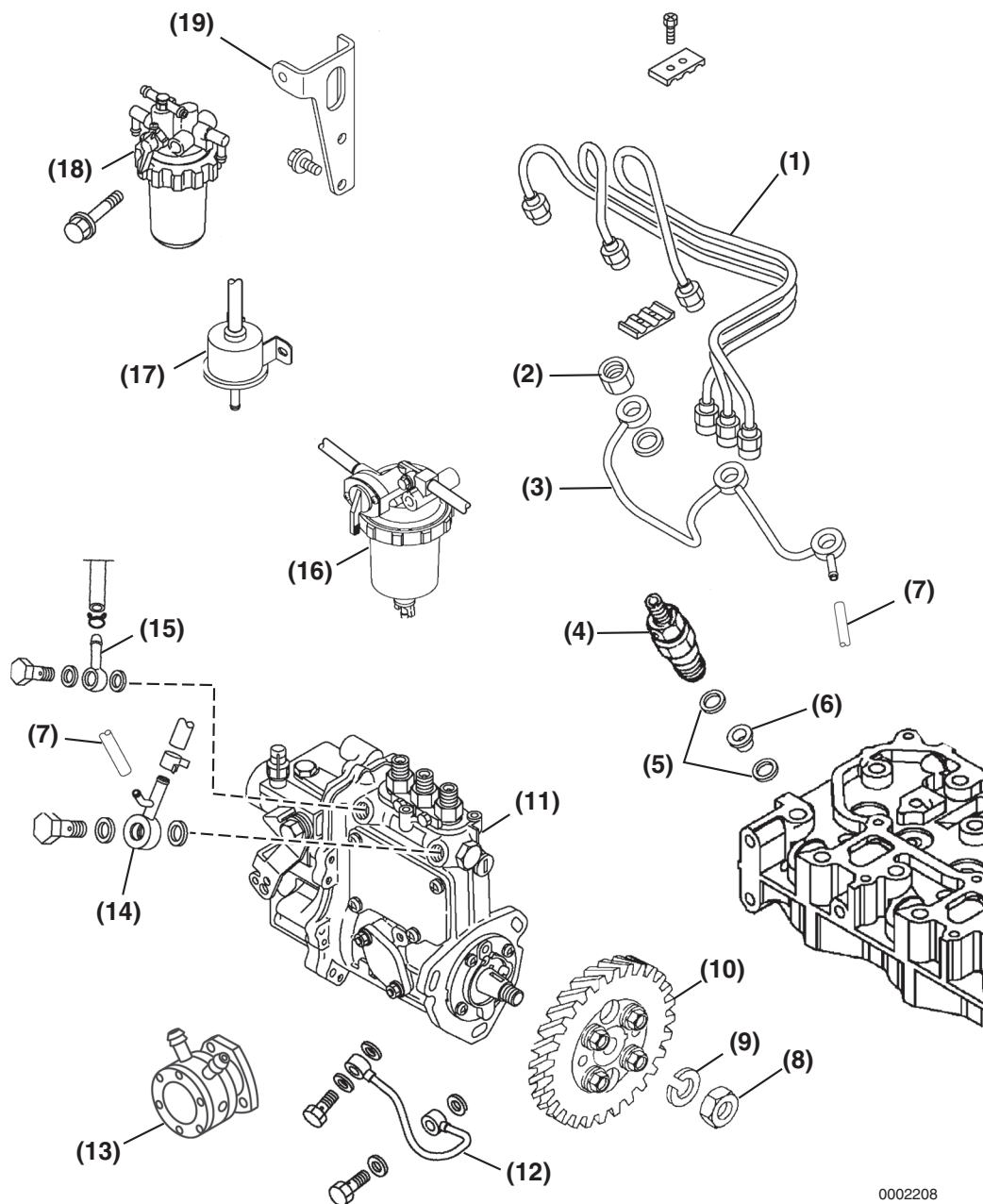

0002208

Figure 7-3

- 1 – High-Pressure Fuel Injection Lines
- 2 – Fuel Return Line Nut
- 3 – Fuel Return Line
- 4 – Fuel Injector
- 5 – Gasket
- 6 – Protector
- 7 – Fuel Return Hose
- 8 – Fuel Injection Pump Drive Gear Nut
- 9 – Lock Washer
- 10 – Fuel Injection Pump Drive Gear Assembly
(DO NOT remove or loosen the four bolts that fasten the injection pump drive gear to the injection pump drive gear hub!)
- 11 – Fuel Injection Pump
- 12 – Lube Oil Line
- 13 – Mechanical Fuel Supply Pump (Optional on some models)
- 14 – Fuel Return Fitting
- 15 – Low Pressure Fuel Inlet Fitting
- 16 – Fuel / Water Separator
- 17 – Electric Fuel Supply Pump
- 18 – Fuel Filter
- 19 – Fuel Filter Mount

FUEL INJECTION LINES

Removal of High-Pressure Fuel Injection Lines

CAUTION

Remove or install the high-pressure fuel injection lines as an assembly whenever possible. Disassembling the high-pressure fuel injection lines from the retainers or bending any of the fuel lines will make it difficult to reinstall the fuel lines.

0000047en

Note: To prevent “rounding” the fuel line nuts always use a “line” or “flare nut” wrench.

1. Close any fuel valves in the fuel supply line.
2. Clean the area to keep contaminants from entering the fuel system.
3. Place a drain pan under the fuel injection pump to catch any spillage.
4. Loosen the fuel line nuts at the fuel injection pump.
5. Next, loosen the fuel line nuts at the fuel injectors. Use one wrench to hold the fuel return line nut and fuel return line from rotating. Use a second wrench to loosen the fuel line nut (**Figure 7-4**). Repeat with the remaining fuel injectors.

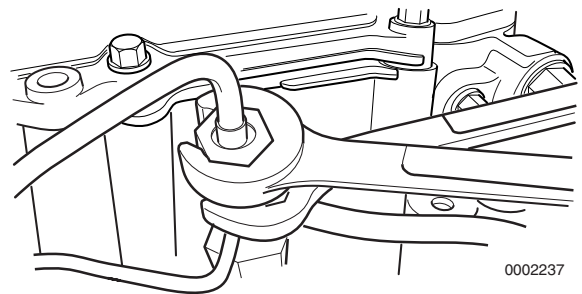

0002237

Figure 7-4

6. Finish loosening all the fuel line nuts and remove the high-pressure fuel lines as an assembly being careful not to bend any of the fuel lines. Be sure to protect the fuel system from contamination by plugging or covering all open connections.
7. Plug or cap all openings to minimize leakage and prevent contamination.

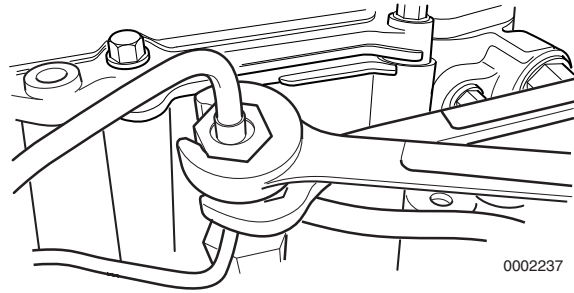

Figure 7-5

Installation of High-Pressure Fuel Injection Lines

CAUTION

Remove or install the high-pressure fuel injection lines as an assembly whenever possible. Disassembling the high-pressure fuel injection lines from the retainers or bending any of the fuel lines will make it difficult to reinstall the fuel lines.

0000047en

Note: To prevent “rounding” the fuel line nuts always use a “line” or “flare nut” wrench.

1. Start all the fuel line nuts by hand. Then use a wrench to just “snug” all the fuel line nuts.
2. Tighten the fuel line nuts on the fuel injection pump to the specified torque. See *Special Torque Chart* on page 7-7.
3. When tightening the fuel line nuts on the fuel injectors, use one wrench to hold the fuel return line nut and fuel return line from rotating. Use a second wrench to tighten the fuel line nuts (**Figure 7-5**). See *Special Torque Chart* on page 7-7.

Removal of Fuel Return Line

1. Clean the area to keep contaminants from entering the fuel system.
2. Remove the high-pressure fuel injection lines as an assembly. See *Removal of High-Pressure Fuel Injection Lines* on page 7-11.

CAUTION

The fuel return line is a one-piece assembly. Use care not to bend or twist the fuel return line.

0000171en

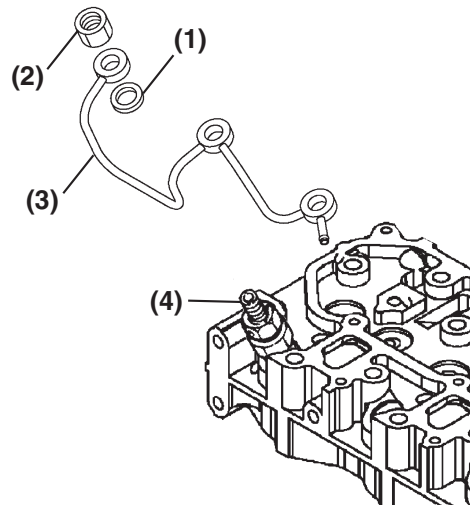

Figure 7-6

3. Remove all fuel return line nuts (**Figure 7-6, (2)**) from the injectors (**Figure 7-6, (4)**).

4. Remove the fuel return hose from the fuel return fitting on the fuel injection pump.
5. Carefully remove the fuel return line assembly (**Figure 7-6, (3)**).
6. Remove and discard the copper gasket (**Figure 7-6, (1)**) from each fuel injector.
7. Plug or cap all openings to minimize leakage and prevent contamination.

Installation of Fuel Return Line

1. Install a new copper gasket on each fuel injector.

CAUTION
The fuel return line is a one-piece assembly. Use care not to bend or twist the fuel return line.
<small>0000171en</small>

2. Carefully reinstall the fuel return line assembly.
3. Reinstall and hand-tighten the fuel return line nuts.
4. Tighten the fuel return line nuts to the specified torque. *See Special Torque Chart on page 7-7.*
5. Reinstall the fuel return hose.
6. Reinstall the high-pressure fuel injection line assembly. *See Installation of High-Pressure Fuel Injection Lines on page 7-12.*

FUEL INJECTION PUMP

Removal of Fuel Injection Pump

1. Loosen the cooling fan V-belt.
2. Remove the engine cooling fan guard (if equipped), engine cooling fan (**Figure 7-7, (2)**), spacer (**Figure 7-7, (3)**) if equipped, V-pulley (**Figure 7-7, (4)**) and cooling fan V-belt (**Figure 7-7, (1)**).

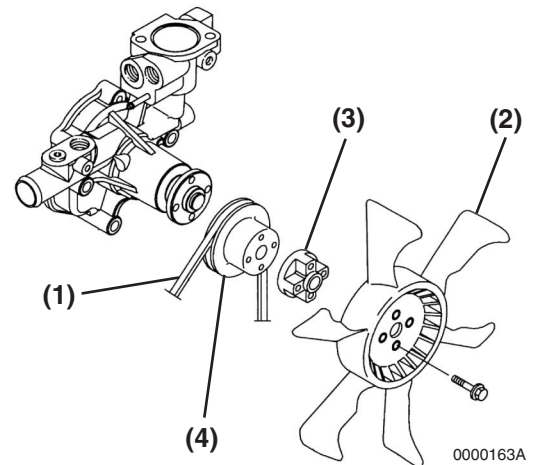

Figure 7-7

3. Close any fuel valves in the fuel supply line.
4. Place a drain pan under the fuel injection pump to catch any spillage.
5. Clean the area to keep contaminants from entering the fuel system.
6. Remove the high-pressure fuel injection lines as an assembly. *See Removal of High-Pressure Fuel Injection Lines on page 7-11.*
7. Disconnect the fuel return lines from the fitting on the fuel injection pump (**Figure 7-8, (1)**). Plug the open ends of the lines to minimize leakage and prevent contamination.

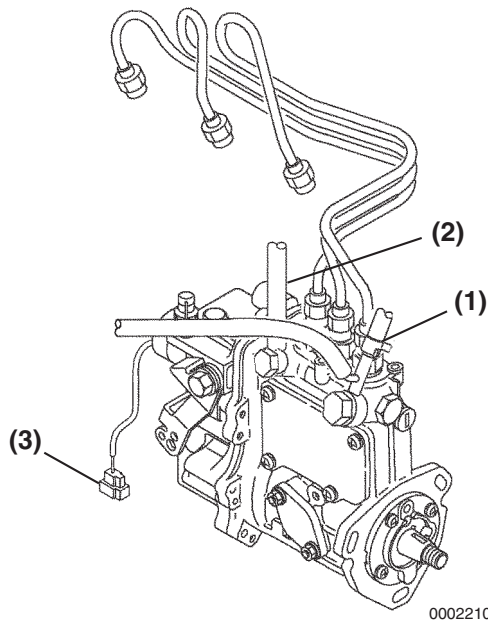

Figure 7-8

8. Remove the fuel supply line (**Figure 7-8, (2)**) from the fitting on the fuel injection pump.
9. Plug or cap all openings to minimize leakage and prevent contamination.
10. Remove the throttle cable from the fuel injection pump.
11. Separate the stop solenoid wiring connector (**Figure 7-8, (3)**).

12. Remove the lube oil line (**Figure 7-9, (1)**) from the fuel injection pump and cylinder block.

IMPORTANT

Take care to not damage or bend the lube oil line.

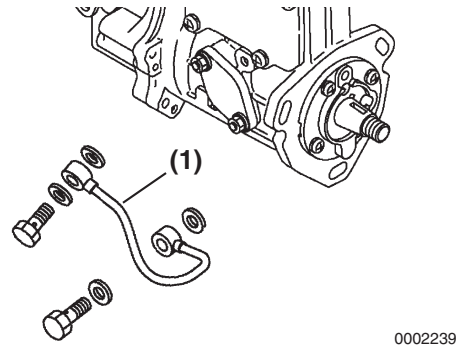

Figure 7-9

13. Remove the fuel injection pump drive gear access cover (**Figure 7-10, (1)**) from the gear case cover (**Figure 7-10, (2)**).

Note: The cover is secured with an adhesive sealant. Use a gasket scraper to separate the cover from the gear case cover.

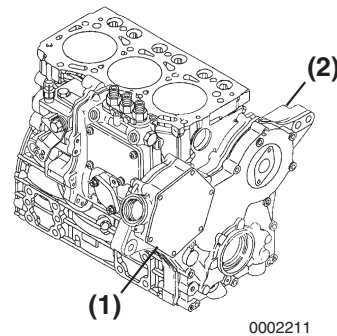

Figure 7-10

14. To aid in reassembly, make reference marks (**Figure 7-11, (1)**) on the drive gear and idler gear.

CAUTION

After marking the position of the pump drive gear, do not rotate the engine crankshaft. Rotating the crankshaft will cause the fuel injection pump to become misaligned.

0000048en

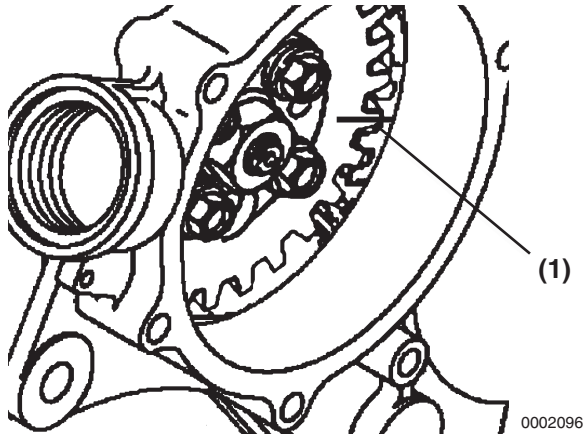

Figure 7-11

0002096

CAUTION

Do not loosen or remove the four bolts retaining the fuel injection pump drive gear to the fuel injection pump hub. Do not disassemble the fuel injection pump drive gear from the hub. Correct fuel injection timing will be very difficult or impossible to achieve.

0000031en

15. Do not loosen or remove the four bolts (Figure 7-12, (3)) holding the pump drive gear to the hub. Only remove the single drive gear retaining nut (Figure 7-12, (1)) and washer (Figure 7-12, (2)), leaving the hub attached to the gear.

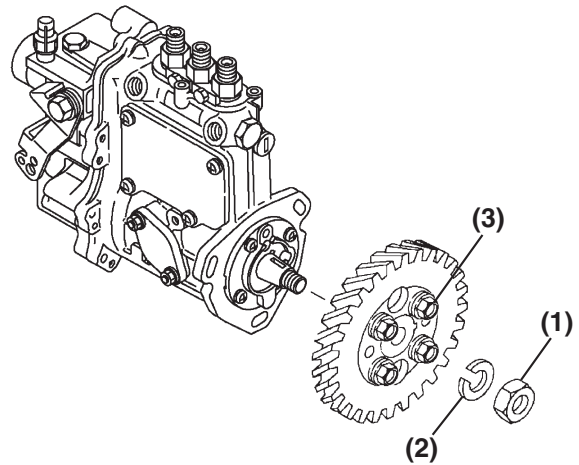
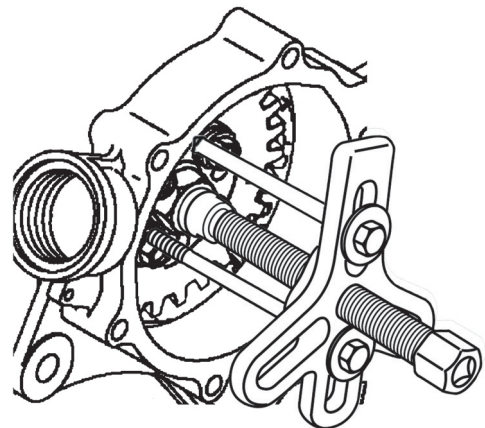

Figure 7-12

16. Hold the gear train stationary using a large socket wrench on the crankshaft pulley bolt. Loosen the fuel injection pump drive gear retaining nut (Figure 7-12, (1)) and turn it out to the end of the fuel injection pump shaft.
17. Remove the injection pump drive gear and hub from the injection pump drive shaft as an assembly using an appropriate gear puller (Figure 7-13).



0002209

Figure 7-13

Note: The injection pump drive gear can be removed from the gear case; however, it is best to let it remain in the gear case.

18. Once the fuel injection pump drive gear and hub assembly have “popped” loose from the tapered fuel injection pump drive shaft, carefully remove the drive gear nut (**Figure 7-14, (1)**) and lock washer (**Figure 7-14, (2)**).

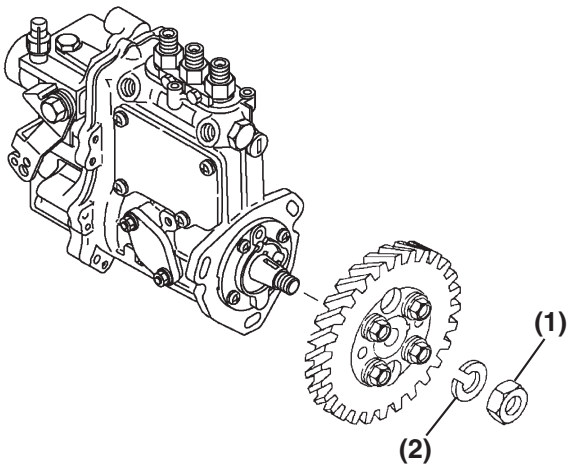

0002183A

Figure 7-14

19. Locate the mark (**Figure 7-15, (1)**) stamped into the upper outside mounting boss of the fuel injection pump. Highlight this mark and make a corresponding mark on the gear case or front plate.

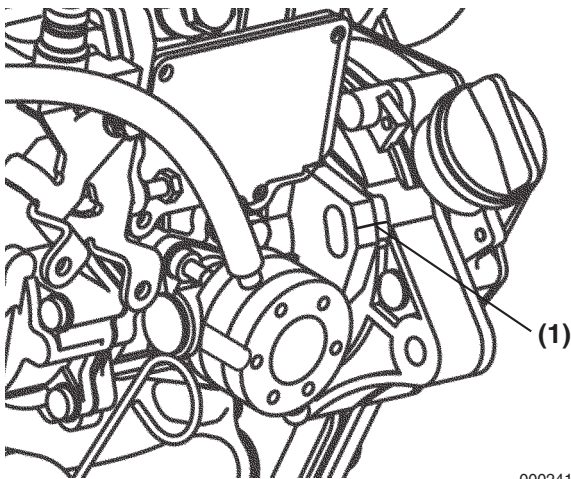

0002416

Figure 7-15

20. Remove the three nuts fastening the fuel injection pump to the gear case. Remove the fuel injection pump. Leave the fuel injection pump drive gear in the gear case and meshed with the idler gear.

CAUTION

Do not rotate the crankshaft with the injection pump removed.

0000083en

21. If the fuel injection pump requires servicing, it must be sent to an authorized Yanmar FIE repair facility for repair and calibration, or replaced with a new fuel injection pump.

CAUTION

- **NEVER** remove or attempt to remove the tamper-proof devices from the full-load fuel adjusting screw or the high-speed throttle limit screw on the fuel injection pump and governor assembly. These adjustments have been made at the factory to meet all applicable emissions regulations and then sealed.
- **NEVER** attempt to make any adjustments to these sealed adjustment screws. If adjustments are required, they can be made only by a qualified fuel injection shop that will ensure the injection pump continues to meet all applicable emissions regulations and then replace the tamper-proof seals.
- Tampering with or removing these devices may void the “Yanmar Limited Warranty.”

0000146en

Installation of Fuel Injection Pump

1. Ensure the fuel injection pump drive gear is aligned with the idler gear using the reference marks made earlier (**Figure 7-16, (1)**).

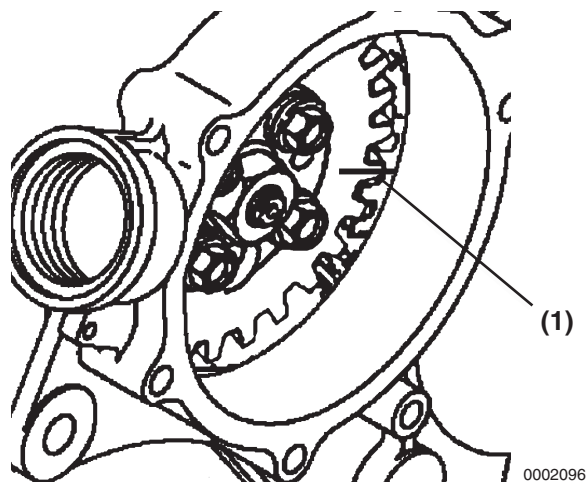
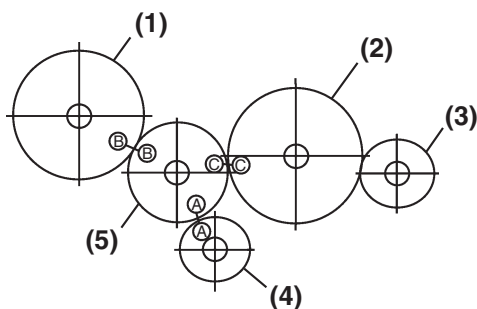

Figure 7-16

2. If installing the fuel injection pump on an engine with the front gear case cover removed, the fuel injection pump drive gear can be aligned with the idler gear by aligning the stamped marks (Figure 7-17, (A, B, C)) on the fuel injection pump drive gear, idler gear, and crankshaft drive gear. Ensure all three timing marks (A, B, C) are aligned.



- 1 – Fuel Injection Pump Drive Gear
- 2 – Camshaft Drive Gear
- 3 – Optional Accessory Drive Gear
- 4 – Crankshaft Drive Gear
- 5 – Idler Gear

Figure 7-17

3. Install a new O-ring on the fuel injection pump mounting flange. Apply some grease to the O-ring to hold it in place during the installation of the fuel injection pump.

Note: Ensure the tapered surface of the fuel injection pump shaft is clean and dry.

4. Align the key on the fuel injection pump shaft with the keyway in the fuel injection pump drive gear hub. Reinstall the fuel injection pump into the fuel injection pump drive gear and gear housing. Install the pump retaining nuts finger-tight.
5. Reinstall the fuel injection pump drive gear lock washer (Figure 7-18, (2)) and nut (Figure 7-18, (1)). Do not lubricate threads of the nut or shaft. Hold the crankshaft pulley bolt with a socket wrench and tighten the drive gear nut to the specified torque. See Special Torque Chart on page 7-7.

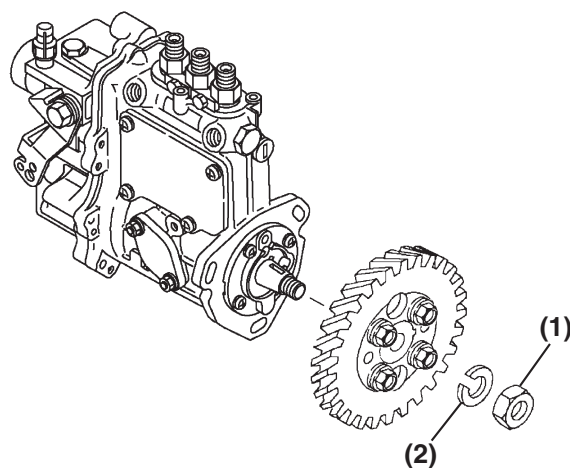
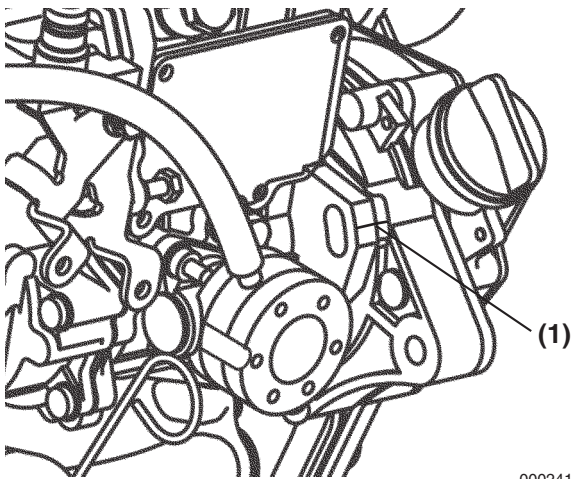

Figure 7-18

6. Align the reference marks (Figure 7-19, (1)) made during disassembly on both the fuel injection pump mounting flange and gear case. If installing a replacement fuel injection pump, align the manufacturer-applied mark on the pump mounting flange with the mark made on the timing gear cover.



0002416

Figure 7-19

7. Tighten the fuel injection pump retaining nuts to specification. See *Special Torque Chart* on page 7-7.
8. Reconnect the fuel supply and return lines to the fuel injection pump.
9. Reconnect the throttle linkage and stop solenoid connector.
10. If installing a new or recalibrated fuel injection pump, check the fuel injection timing before completing the installation of the fuel injection pump. See *Checking and Adjusting Fuel Injection Timing* on page 7-19.

Note: While it is not required to check the injection timing when reinstalling the original fuel injection pump, it is recommended that it be done.

11. Reinstall the lube oil line (**Figure 7-20, (1)**).

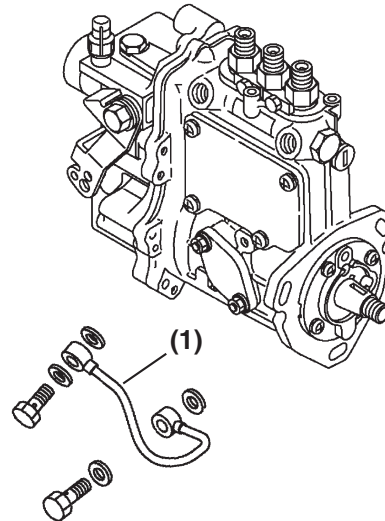

0002239

Figure 7-20

12. Apply ThreeBond Liquid Gasket No. 1212, Yanmar Part No. 977770-01212, or equivalent sealant to the sealing surface of the fuel injection pump drive gear access cover. Reinstall the cover on the front of the gear case and tighten the bolts.
13. Reinstall the fuel injection high-pressure lines. See *Installation of High-Pressure Fuel Injection Lines* on page 7-12.

IMPORTANT

When installing a new or repaired fuel injection pump, add 5 - 7 oz (150 - 200 cc) of new, clean engine oil to the fuel injection pump at the fill plug located in the upper outside section of the governor housing.

14. Reinstall the coolant pump V-pulley (**Figure 7-21, (4)**), spacer (**Figure 7-21, (3)**) (if equipped) and engine cooling fan (**Figure 7-21, (2)**).

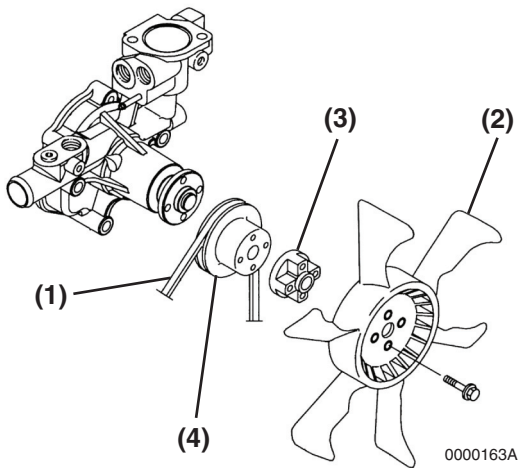

Figure 7-21

15. Reinstall the cooling fan V-belt (**Figure 7-21, (1)**). Adjust as described in *Check and Adjust Cooling Fan V-Belt* on page 5-27.
16. Reinstall the cooling fan guard (if equipped).
17. Prime the fuel system. See *Priming the Fuel System* on page 4-12.
18. Operate the engine and check for fuel and lube oil leaks.

CHECKING AND ADJUSTING FUEL INJECTION TIMING

Note: The following procedure is performed on the No. 1 cylinder. While checking and adjusting the timing on only No. 1 cylinder is usually sufficient, the same procedure can be performed on any or all cylinders.

Checking Fuel Injection Timing

Note: Some fuel may drain from the fuel injection pump during this process. Make provisions to contain and dispose of any such spillage.

1. Ensure the fuel injection pump is primed with fuel. See *Priming the Fuel System* on page 4-12.

2. Clean the area around the fuel injection pump.

Note: The stop solenoid must be removed to allow fuel to flow through the fuel injection pump.

3. Remove two screws (**Figure 7-22, (1)**). Remove the stop solenoid (**Figure 7-22, (2)**) and O-ring (**Figure 7-22, (3)**).

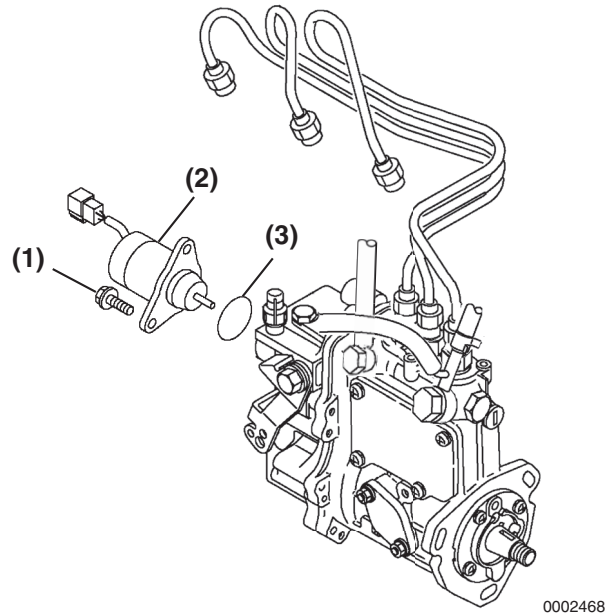

Figure 7-22

4. Set the throttle to the HIGH-IDLE position.
5. Using a wrench on the crankshaft pulley bolt, rotate the crankshaft in a clockwise direction while looking through the flywheel inspection port (**Figure 7-23, (1)**). Rotate the crankshaft until the injection timing marks on the flywheel are visible for No. 1 cylinder.

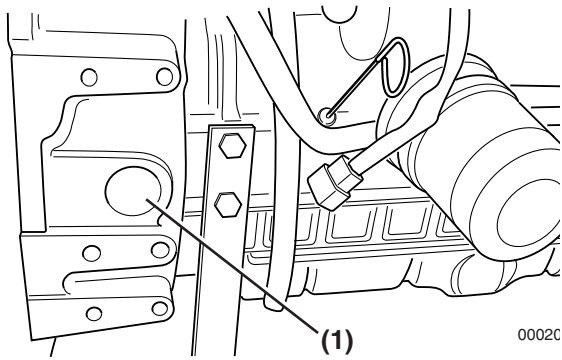
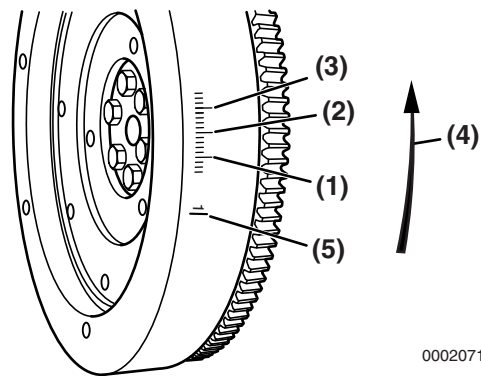

Figure 7-23

6. Typical flywheel markings are as shown in **(Figure 7-24)**.

Note: A typical flywheel will have multiple timing grids depending on the number of cylinders. Any grid and its corresponding cylinder can be used to check the fuel injection timing.



- 1 – 15° BTDC (Before Top Dead Center)
- 2 – 20° BTDC
- 3 – 25° BTDC
- 4 – Direction of Rotation
- 5 – TDC (Top Dead Center)

Figure 7-24

7. The flywheel shown in **(Figure 7-24)** is for a Yanmar “Standard Specification” IDI engine. Flywheels used on some “OEM Specific” IDI engines may be marked differently. You should contact that specific OEM for information on the identification of the timing marks.

Note: The TDC (Top Dead Center) mark can be identified by the cylinder numbers stamped near the TDC mark **(Figure 7-24, (5))** on the flywheel.

8. If you are uncertain as to the timing degree designation of the timing marks on the flywheel timing grid, you can determine the timing degree designation by measuring the timing grid.
- First measure the distance between two of the “longer” marks on the timing grid. (They are 5° apart.) Then measure the distance from the TDC mark to the first “longer” mark on the timing grid. Divide that measurement by the distance between the two “longer” marks. The resulting answer will tell you how many degrees there are between the TDC mark and the first “longer” mark.

- EXAMPLE: If the distance between the two “longer” marks is approximately 2.0 cm and the distance from the TDC mark is approximately 4.0 cm, the answer is approximately 2. This indicates there is 10° (2 x 5°) between the TDC mark and the first “longer” mark on the timing grid. That means the first “longer” mark on the timing grid indicates 10° BTDC, the second “longer” mark indicates 15° BTDC and the third timing mark indicates 20°. If the answer is 3, that indicates there is 15° (3 x 5°) between the TDC mark and the first “longer” mark and that the first “longer” mark indicates 15° BTDC with the second and third “longer” marks indicating 20° BTDC and 25° BTDC respectively.

9. Highlight the timing reference mark on the flywheel housing (Figure 7-25, (2)) or engine back plate (Figure 7-26, (2)). Highlight the TDC (Top Dead Center) mark (Figure 7-25, (1)), (Figure 7-26, (1)) on the flywheel.

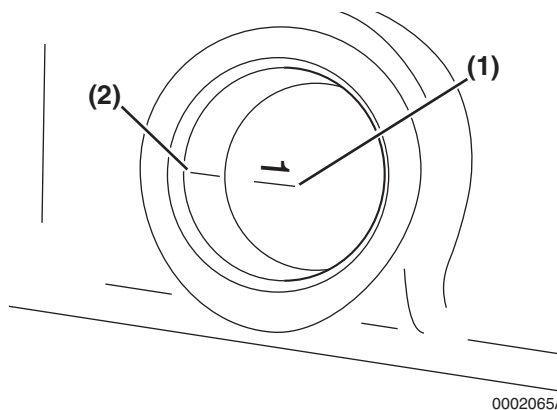

Figure 7-25

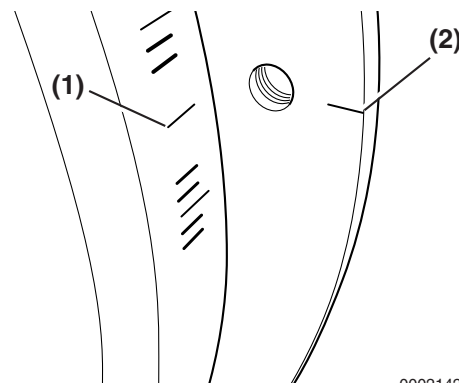

Figure 7-26

10. Highlight the target timing mark (Figure 7-26, (1)), (Figure 7-27, (1)) on the flywheel timing grid as determined in the Fuel Injection Timing Chart below.

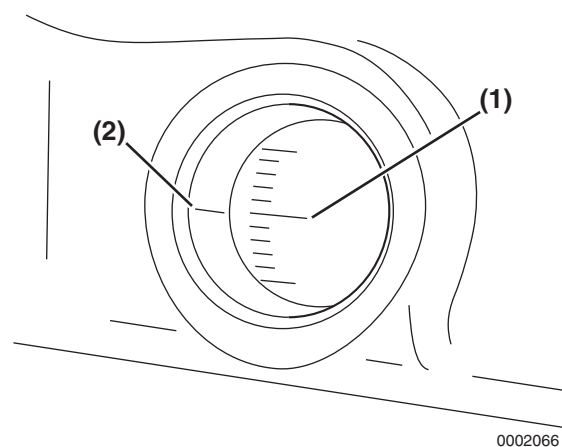

Figure 7-27

Fuel Injection Timing Chart

Model		CL		VM			CH	VH		
Engine Speed (rpm)		1500	1800	2000 to 2100	2200	2300 to 2600	2700 to 3000	3000 to 3600	3100 to 3400	3500 to 3600
2TNV70	Injection Timing BTDC ±1°	-	-	15°		16°	18°	21°	20°	21°
3TNV70		16°		15°		16°	18°	21°	20°	21°
3TNV76		15°		15°	16°		18°	21°	20°	21°

11. Remove all high-pressure fuel injection lines. See Removal of High-Pressure Fuel Injection Lines on page 7-11.
12. Turn on all fuel supply valves.

Note: As the injection pump injects fuel to a cylinder only once every two engine revolutions, it may be necessary to rotate the crankshaft twice to see fuel being pumped from the timing tool or delivery valve of the cylinder you are using to check injection timing.

13. Install the “spill-timing” tool (**Figure 7-28, (1)**) onto the delivery valve for the cylinder being checked. See *Measuring Instruments on page 7-8*.

Note: If a timing tool is not available, timing can be checked by watching the fuel in the delivery valve itself.

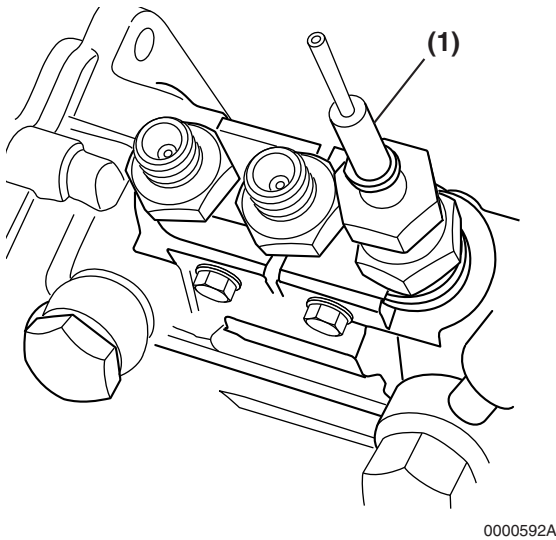

Figure 7-28

Note: The following references to the direction of rotation are made facing the cooling fan end of the engine and are adjusted by turning the crankshaft.

14. Slowly rotate the crankshaft clockwise using a wrench on the crankshaft pulley bolt until fuel is pumped from the nozzle of the “spill-timing” tool or delivery valve.
15. Slowly rotate the crankshaft clockwise approximately two more revolutions until the timing grid on the flywheel (for the cylinder being checked) is at approximately 30° BTDC.

Note: The fuel injection pump injects fuel to a cylinder only once every two engine revolutions.

16. “Flick” the nozzle of the timing tool with a finger to remove bubbles and establish a fuel level of approximately 1/2 the height of the nozzle.
17. Very slowly rotate the crankshaft clockwise until the fuel level in the nozzle of the “spill timing” tool, or in the delivery valve, just begins to move. Immediately stop rotating the crankshaft.
18. Check the position of the flywheel target timing mark (**Figure 7-27, (1)**) on the flywheel grid in relation to the timing reference mark (**Figure 7-27, (2)**) on the flywheel housing or back plate. If the two marks are aligned, the fuel injection timing is correct. If the marks do not align, the fuel injection timing must be adjusted. See *Adjusting Fuel Injection Timing on page 7-23*.
19. Repeat Steps 13-17 two or three times to verify timing.
20. Remove the “spill-timing” tool.
21. Reinstall the shut-off solenoid.
22. Reinstall the high-pressure fuel injection lines. See *Installation of High-Pressure Fuel Injection Lines on page 7-12*.
23. Replace the flywheel inspection port cover.
24. Prime the fuel system. Operate the engine and check for leaks.

Adjusting Fuel Injection Timing

If the timing marks did not align when performing the *Checking Fuel Injection Timing on page 7-19*, the following steps must be performed to properly time the engine.

1. Leave the “spill-timing” tool installed in the fuel injection pump.
2. Determine if the timing is “advanced” or “retarded” by comparing the position of the target timing mark on the flywheel grid (**Figure 7-29, (1)**) with the timing mark on the flywheel housing or back plate (**Figure 7-29, (2)**).

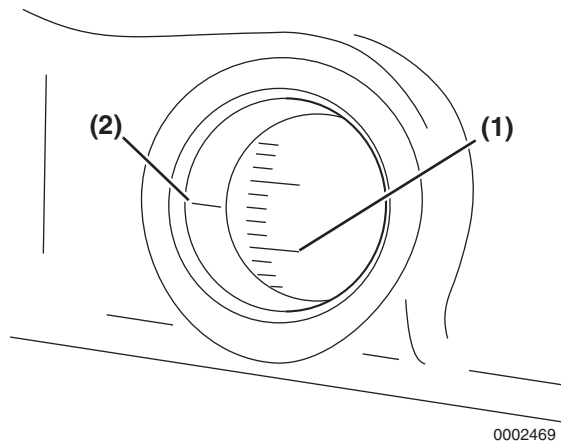

Figure 7-29

3. Loosen the nuts fastening the fuel injection pump to the gear case.
4. If the injection timing was less than the target timing, the injection timing is “retarded” and will need to be “advanced.”

To “advance” the injection timing: Rotate the top of the fuel injection pump away from the engine.

If the injection timing was greater than the target timing, the injection timing is “advanced” and will need to be “retarded.”

To “retard” the injection timing: Rotate the top of the fuel injection pump toward the engine.

5. Adjust the position of the fuel injection pump and tighten the fuel injection pump mounting nuts.
6. Recheck the fuel injection timing. Repeat the fuel injection timing and adjustment procedures until the timing is correct. *See Checking Fuel Injection Timing on page 7-19 and repeat steps 3 - 6.*
7. Remove the “spill-timing” tool.
8. Reinstall the shut-off solenoid.
9. Reinstall the high-pressure fuel injection lines. *See Installation of High-Pressure Fuel Injection Lines on page 7-12.*
10. Replace the flywheel inspection port cover.
11. Prime the fuel system. Operate the engine and check for leaks.

FUEL INJECTORS

Removal of Fuel Injectors

1. Close any fuel valves in the fuel supply line.
2. Clean the area around the fuel injection pump and fuel injectors to keep contaminants from entering the engine or fuel system.
3. Remove the high-pressure fuel injection lines as an assembly. *See Removal of High-Pressure Fuel Injection Lines on page 7-11.*
4. Remove nut (**Figure 7-30, (1)**). Remove the fuel return line (**Figure 7-30, (2)**) and copper washer (**Figure 7-30, (3)**) from the fuel injectors. *See Removal of Fuel Return Line on page 7-12.*

Note: The fuel injectors used on IDI engines screw into the cylinder head.

5. Remove the fuel injectors (**Figure 7-30, (4)**).

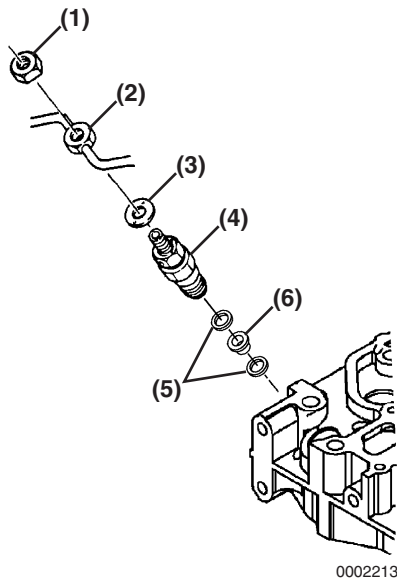

Figure 7-30

- 6. Remove the injector nozzle gaskets (**Figure 7-30, (5)**) and protector (**Figure 7-30, (6)**) from the cylinder head.

Testing of Fuel Injectors

CAUTION
<p>Never use a steel wire brush to clean fuel injectors. Damage to the nozzle and other components is likely to result.</p> <p style="text-align: right; font-size: small;">0000172en</p>

- 1. Thoroughly clean the fuel injector nozzle using clean diesel fuel and a brass wire brush.
- 2. Visually inspect the fuel injectors and nozzle protectors for deposits or damage. Clean, repair or replace as necessary.

Note: Test the fuel injector using an injection nozzle tester. Operate the tester following the information provided by the tester manufacturer. Use clean, filtered fuel or FIE calibration fluid for the test.

- 3. Using the correct adapter, connect a fuel injector to a nozzle tester. Aim the fuel injector into a suitable container to catch the fuel spray (**Figure 7-31**).

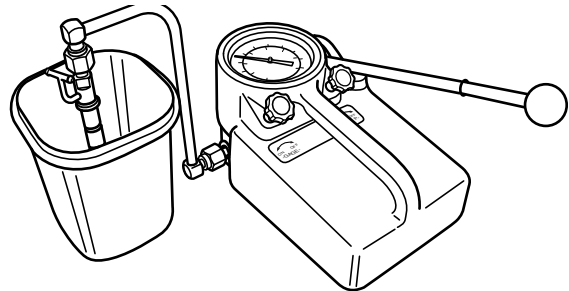



Figure 7-31

⚠ WARNING

<p>HIGH-PRESSURE HAZARD!</p> <ul style="list-style-type: none"> • Avoid skin contact with the high-pressure diesel fuel spray caused by a fuel system leak such as a broken fuel injection line. High-pressure fuel can penetrate your skin and result in serious injury. If you are exposed to high-pressure fuel spray, obtain prompt medical treatment. • NEVER check for a fuel leak with your hands. ALWAYS use a piece of wood or cardboard. Have your authorized Yanmar industrial engine dealer or distributor repair the damage. • Failure to comply could result in death or serious injury. <p style="text-align: right;">000008en</p>

⚠ WARNING







<p>To prevent possible eye injury, always wear SAFETY GLASSES while servicing the engine.</p> <p style="text-align: right;">0000013en</p>

4. Pump the operating lever of the tester slowly, observing the pressure reading at the point where the fuel injector begins spraying fuel. *See Test and Adjustment Specifications on page 7-7 for correct pressure readings.*

Note: Opening pressure of a new fuel injector will be approximately 72.5 psi (0.5 MPa; 5 kgf/cm²) higher than one that has been operated for five hours or longer.

5. Pump the operating lever slowly to hold the pressure steady at a point just below the opening pressure and hold that pressure for five seconds. Observe the injector to see that it is sealing properly and is not “dripping.” If fuel leaks from the return line fitting, check that the nozzle case nut is tight. Service or replace the injector if fuel continues to leak from either the return line fitting or nozzle.
6. Pump the operating lever more rapidly to repeatedly “pop” the injector and observe the spray pattern. The pattern should be a very fine uniform spray. If dripping or an uneven pattern is seen, service or replace the injector. *See Fuel Injector Test Results on page 7-26.*

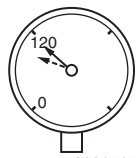
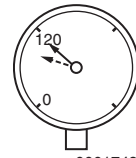
Fuel Injector Test Results

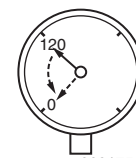
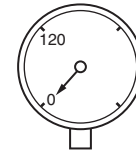
	A	B	C	D	E
Injection Pattern	 0001742	 0001743	 0001744		
Pressure Gauge Reading	 0001747 Gauge needle fluctuates around the valve opening pressure.	 0001748 Gauge needle fluctuates around the valve opening pressure.	 0001749 Gauge needle stays at a position near the valve opening pressure.	 0001750 Although the gauge needle reaches the valve opening pressure, the pressure drop is large.	 0001751 Pressure does not increase even when the tester lever is operated.
Atomization Pattern	5°-10° cone and roughly uniform.	Atomization is excessively one-sided.	Although atomized (burner like shape), the needle does not pulsate.	Bar shape with excessive after drops.	Drops.
Possible Cause	(Normal, injector is good)	Normally caused by carbon contamination of the nozzle tip. Sometimes caused by flaws in or damage to the needle tip.	Caused by excessive carbon contamination of the nozzle tip. Sometimes caused by internal contamination.	Damage to the seat. Contamination of seat by fine foreign particles. Excessively worn seat.	Sticking of needle. Excessively damaged or worn seat. Contamination of seat by foreign matter. Damaged or broken internal parts or nozzle case nut.

Note: If the fuel injector fails any tests, it should be serviced or replaced as necessary. If the pressure is outside specified limits, adjust the pressure. See *Adjusting Fuel Injector Pressure* on page 7-28.

Disassembly and Inspection of Fuel Injectors

CAUTION

Never use a steel wire brush to clean fuel injectors. Damage to the nozzle and other components is likely to result.

0000172en

1. Clean carbon from used injectors using clean diesel fuel. Hardened deposits or varnish can be cleaned using a brass wire brush.

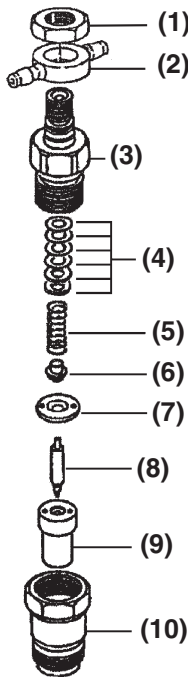

- 1 – Return Fuel Fitting Nut
- 2 – Return Fuel Fitting
- 3 – Injector Body
- 4 – Pressure Adjusting Shims
- 5 – Spring
- 6 – Spring Seat
- 7 – Valve Stop Spacer
- 8 – Nozzle Valve
- 9 – Nozzle Body
- 10 – Nozzle Case Nut

Figure 7-32

2. Place the fuel injector in a soft-jawed vise with the nozzle pointing up.

3. Remove the nozzle case nut.
4. Carefully remove the injector from the vise.
5. Turn the injector over and remove the nozzle body, nozzle valve, valve stop spacer, nozzle spring seat, nozzle spring, and shims.
6. Inspect the sealing surfaces (**Figure 7-33, (2)**) between the valve stop spacer and nozzle body for nicks or scratches. Check the contact area between the valve stop spacer and the nozzle valve (**Figure 7-33, (1)**) for scoring or pitting. Use a magnifying glass to inspect.

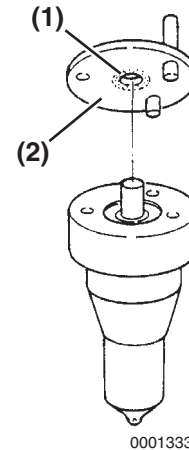

Figure 7-33

0002214

7. Perform a nozzle valve slide test:
 - (a) Wash nozzle body and valve in clean diesel fuel.
 - (b) While holding the nozzle body vertical, pull the nozzle valve about 2/3 of the way out (**Figure 7-34**).
 - (c) Release the valve. It should fall smoothly to its seat by its own weight.

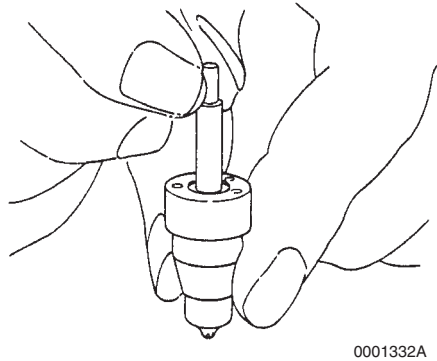

Figure 7-34

Replace the fuel injector assembly if it fails any inspection.

Adjusting Fuel Injector Pressure

The fuel injectors open when pressure reaches a predetermined pressure threshold. They close when the pressure is reduced below that threshold. The pressure threshold can be adjusted by adding or removing shims (**Figure 7-35, (4)**).

Fuel Injector Shim Kit	
Yanmar Part No. 129901-53800	
(Includes one each of the following shims)	
129901-53810	0.0039 in. (0.10 mm)
129901-53820	0.0079 in. (0.20 mm)
129901-53830	0.0118 in. (0.30 mm)
129901-53840	0.0157 in. (0.40 mm)
129901-53850	0.0197 in. (0.50 mm)
129901-53860	0.0205 in. (0.52 mm)
129901-53870	0.0213 in. (0.54 mm)
129901-53880	0.0220 in. (0.56 mm)
129901-53890	0.0228 in. (0.58 mm)
129901-53900	0.0315 in. (0.80 mm)

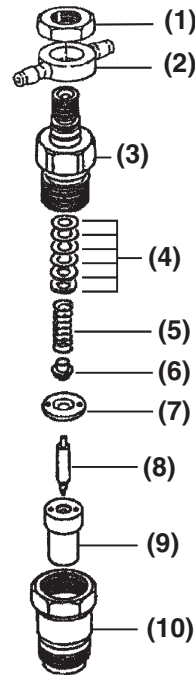

- 1 – Return Fuel Fitting Nut
- 2 – Fuel Return Fitting
- 3 – Injector Body
- 4 – Pressure Adjusting Shims
- 5 – Spring
- 6 – Spring Seat
- 7 – Valve Stop Spacer
- 8 – Nozzle Valve
- 9 – Nozzle Body
- 10 – Nozzle Case Nut

Figure 7-35

The injection pressure will change by approximately 100 - 142 psi (0.69 - 0.98 MPa; 7 - 10 kgf/cm²) for every 0.004 in. (0.1 mm) shim thickness.

See the parts catalog for available shims.

1. Disassemble the fuel injector assembly. See *Disassembly and Inspection of Fuel Injectors on page 7-27*.
2. Remove or add adjusting shims as needed.
3. Reassemble the fuel injector assembly. See *Reassembly of Fuel Injectors on page 7-29*.

- Retest the fuel injector. See *Testing of Fuel Injectors* on page 7-24. If the injector cannot be adjusted to the appropriate pressure, discard the fuel injector.

Reassembly of Fuel Injectors

- Secure the injector in a soft-jawed vise with the nozzle end up.
- Reinstall the shims, nozzle spring, nozzle spring seat, valve stop spacer, nozzle valve, and nozzle body.
- Reinstall the nozzle case nut. Tighten it to specification.

Installation of the Fuel Injectors

- Insert the nozzle gaskets (**Figure 7-36, (5)**) and nozzle protector (**Figure 7-36, (6)**) in the cylinder head.
- Reinstall the fuel injector (**Figure 7-36, (4)**) in the cylinder head and tighten to specification.
- Reinstall new copper washers (**Figure 7-36, (3)**), high-pressure and return fuel lines (**Figure 7-36, (2)**). See *Installation of High-Pressure Fuel Injection Lines* on page 7-12 and *Installation of Fuel Return Line* on page 7-13. Tighten fuel line nuts (**Figure 7-36, (1)**) to specifications.
- Prime the fuel system. See *Priming the Fuel System* on page 4-12.
- Operate the engine and check for fuel leaks.

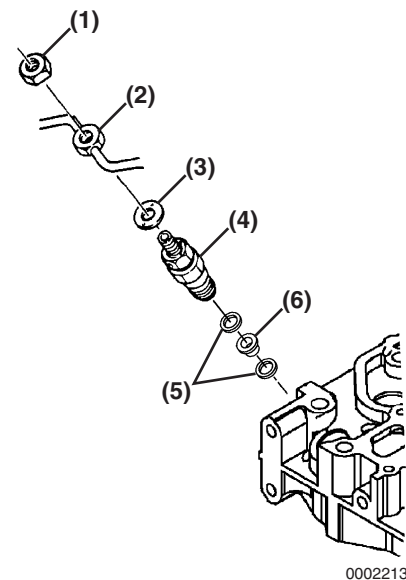

Figure 7-36

0002213

This Page Intentionally Left Blank

Section 8

COOLING SYSTEM

	Page
Before You Begin Servicing	8-3
Introduction.....	8-5
Cooling System Diagram.....	8-5
Engine Coolant Pump Components	8-6
Engine Coolant System Check.....	8-7
Engine Coolant Pump	8-7
Disassembly of Engine Coolant Pump	8-7
Cleaning and Inspection	8-8
Reassembly of Engine Coolant Pump.....	8-9

This Page Intentionally Left Blank

BEFORE YOU BEGIN SERVICING

⚠ DANGER



SCALD HAZARD!

- NEVER remove the radiator cap if the engine is hot. Steam and hot engine coolant will spurt out and seriously burn you. Allow the engine to cool down before you attempt to remove the radiator cap.
- Tighten the radiator cap securely after you check the radiator. Steam can spurt out during engine operation if the cap is loose.
- ALWAYS check the level of the engine coolant by observing the reserve tank.
- Failure to comply will result in death or serious injury.

000002en

⚠ WARNING



BURN HAZARD!

- Wait until the engine cools before you drain the engine coolant. Hot engine coolant may splash and burn you.
- Failure to comply could result in death or serious injury.

0000016en

⚠ WARNING



ENTANGLEMENT HAZARD!

- Stop the engine before you begin to service it.
- NEVER leave the key in the key switch when you are servicing the engine. Someone may accidentally start the engine and not realize you are servicing it. This could result in a serious injury.
- If you must service the engine while it is operating, remove all jewelry, tie back long hair, and keep your hands, other body parts and clothing away from moving / rotating parts.
- Failure to comply could result in death or serious injury.

0000010en

⚠ WARNING



FUME / BURN HAZARD!

- Always read and follow safety related precautions found on containers of hazardous substances like parts cleaners, primers, sealants and sealant removers.
- Failure to comply could result in death or serious injury.

0000014en

⚠ WARNING



BURN HAZARD!

- If you must drain the engine oil while it is still hot, stay clear of the hot engine oil to avoid being burned.
- **ALWAYS** wear eye protection.
- Failure to comply could result in death or serious injury.

0000011en

⚠ CAUTION



PINCH HAZARD!

Carefully rotate the alternator toward the cylinder block while loosening the V-belt. Failure to comply may result in minor or moderate injury.

0000014en

⚠ CAUTION



FLYING OBJECT HAZARD!

- **ALWAYS** wear eye protection when servicing the engine and when using compressed air or high-pressure water. Dust, flying debris, compressed air, pressurized water or steam may injure your eyes.
- Failure to comply may result in minor or moderate injury.

0000003en

CAUTION

- Only use the engine coolant specified. Other engine coolants may affect warranty coverage, cause an internal buildup of rust and scale and / or shorten engine life.
- Prevent dirt and debris from contaminating the engine coolant. Carefully clean the radiator cap and the surrounding area before you remove the cap.
- **NEVER** mix different types of engine coolants. This may adversely affect the properties of the engine coolant.

0000006en

CAUTION

If the engine coolant pump must be replaced, replace the engine coolant pump as an assembly only. Do not attempt to repair the engine coolant pump or replace individual components.

0000041en

CAUTION

Use a new special O-ring between the engine coolant pump and the joint. Be sure to use the special O-ring for each engine model. Although the O-ring dimensions are the same as a commercially available O-ring, the material is different.

0000042en

INTRODUCTION

This section of the *Service Manual* describes the procedures necessary to service the 2TNV70, 3TNV70 and 3TNV76 engine coolant pump.

COOLING SYSTEM DIAGRAM

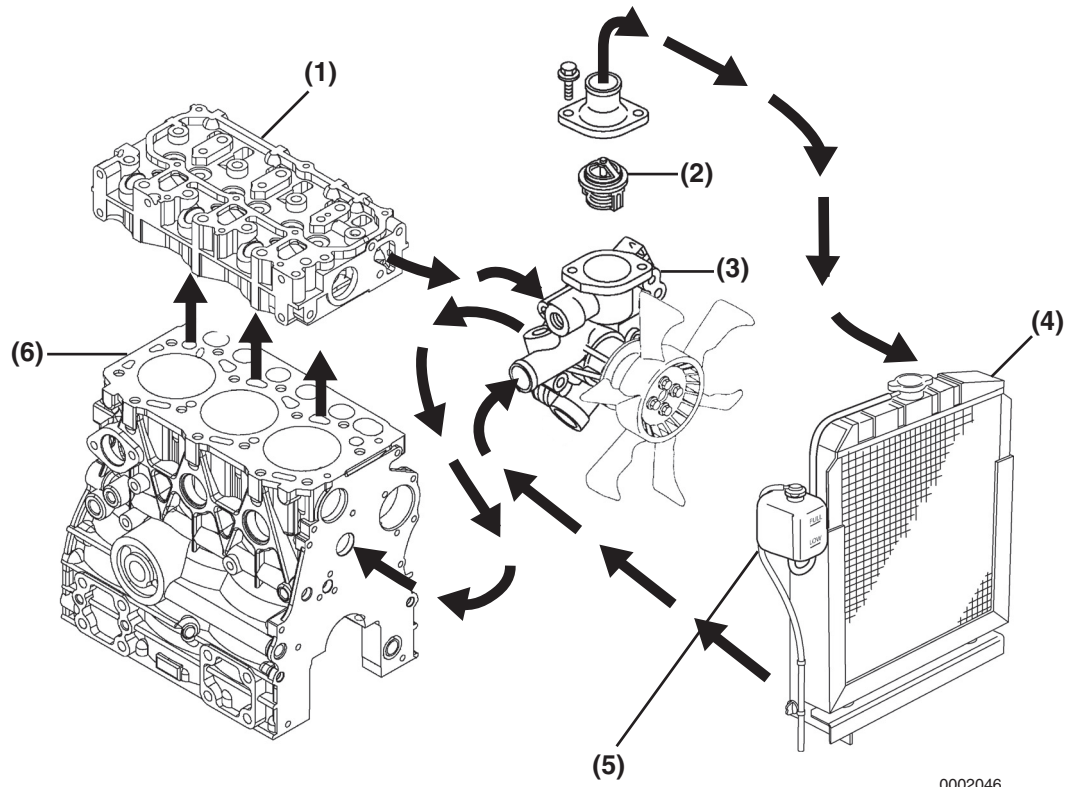

0002046

Figure 8-1

- 1 – Cylinder Head
- 2 – Thermostat
- 3 – Engine Coolant Pump

- 4 – Radiator
- 5 – Coolant Recovery Tank
- 6 – Cylinder Block

ENGINE COOLANT PUMP COMPONENTS

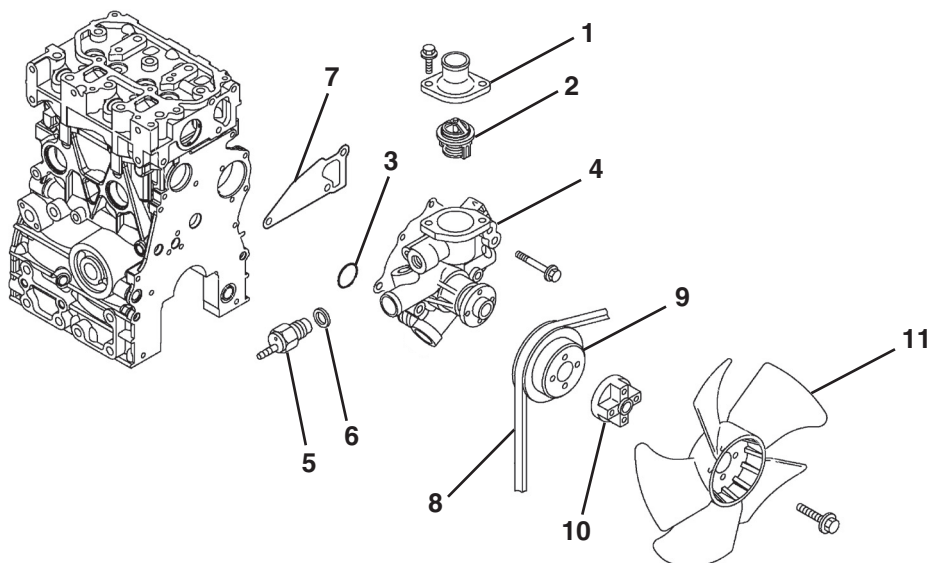

0001959

Figure 8-2

- | | |
|-------------------------|----------------------------------|
| 1 – Thermostat Cover | 7 – Engine Coolant Pump Gasket |
| 2 – Thermostat | 8 – V-Belt |
| 3 – Special O-Ring | 9 – Engine Coolant Pump V-Pulley |
| 4 – Engine Coolant Pump | 10 – Spacer |
| 5 – Temperature Switch | 11 – Engine Coolant Fan |
| 6 – Gasket | |

ENGINE COOLANT SYSTEM CHECK

Check the engine coolant system for leakage.

1. With the radiator properly filled, install a cooling system tester (Figure 8-3, (1)).

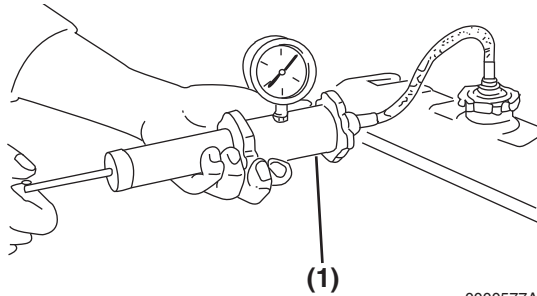

Figure 8-3

0000577A

2. Apply 10.8 - 14.8 psi (75 - 105 kPa; 0.75 - 1.05 kgf/cm²) to the cooling system. If the pressure reading drops, the engine coolant system is leaking. Identify the source of the leak and repair.

ENGINE COOLANT PUMP

Disassembly of Engine Coolant Pump

Verify the condition of the engine coolant pump before disassembling it from the engine. Check the engine coolant pump shaft bearing for abnormal noise, sticking, excessive play and water leakage. Replace the coolant pump if any of these conditions are present.

CAUTION

If the engine coolant pump must be replaced, replace the engine coolant pump as an assembly only. Do not attempt to repair the engine coolant pump or replace individual components.

0000041en

1. Make sure the engine and engine coolant are not hot.

2. Before removing the engine coolant pump or thermostat, it will be necessary to drain the engine coolant. Drain the coolant into a clean container if the coolant is to be reused. Otherwise, properly dispose of the coolant.
 - Drain the coolant from the radiator. See steps 1 - 4 in *Drain, Flush and Refill Cooling System with New Coolant* on page 5-33.
3. Loosen the alternator mounting bolts. Loosen and remove the V-belt and rotate the alternator away from the engine and out of the way.

CAUTION



PINCH HAZARD!

Carefully rotate the alternator toward the cylinder block while loosening the V-belt. Failure to comply may result in minor or moderate injury.

0000014en

4. Remove the engine coolant fan guard (if equipped), engine coolant fan (Figure 8-4, (1)), spacer (Figure 8-4, (2)) and engine coolant pump V-pulley (Figure 8-4, (3)).

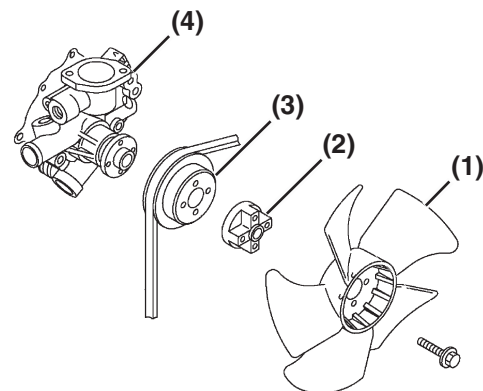

Figure 8-4

0001959B

5. Disconnect the coolant hoses and the temperature switch lead wire from the engine coolant pump.

6. Remove the engine coolant pump (Figure 8-4, (4)). Discard the gasket.
7. Remove the thermostat cover (Figure 8-5, (1)).

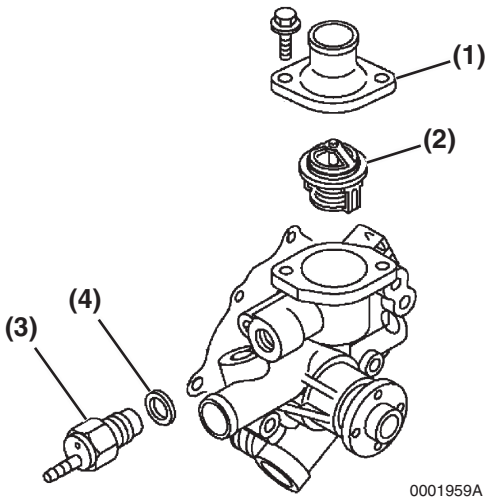

Figure 8-5

8. Remove the thermostat (Figure 8-5, (2)). Remove the temperature switch (Figure 8-5, (3)) and gasket (Figure 8-5, (4)). Discard the gasket.

Cleaning and Inspection

Temperature Switch

1. Check for proper operation of the temperature switch. Connect a continuity light or ohmmeter to the temperature switch. Connect one lead to the terminal of the switch (Figure 8-6, (1)) and the other lead to the metal portion of the switch (Figure 8-6, (2)).

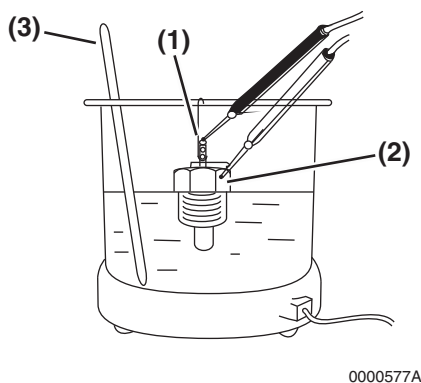

Figure 8-6

2. Place the temperature switch and an accurate thermometer (Figure 8-6, (3)) in engine coolant.
3. Slowly increase temperature of the fluid using an external heat source.
4. The temperature switch is normal if the continuity light or ohmmeter indicates continuity when the fluid temperature reaches 225°F - 235°F (107°C - 113°C).

Thermostat

1. Check for proper operation of the thermostat. Place the thermostat (Figure 8-7, (1)) and an accurate thermometer (Figure 8-7, (2)) in warm water.

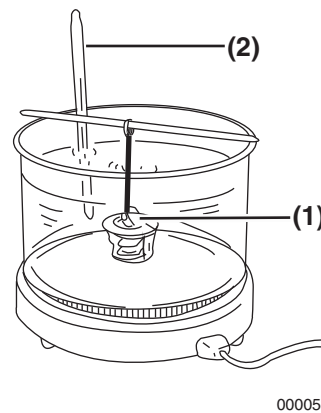
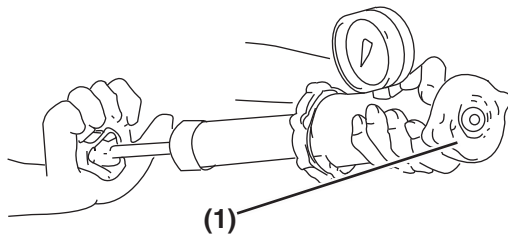

Figure 8-7

2. Slowly increase temperature of the water using an external heat source.
3. The thermostat is normal if it starts to open at the temperature value stamped on the flange of the thermostat, and fully opens as the temperature of the water is increased.

Radiator Cap

1. Check for proper operation of the radiator cap. Install the radiator cap (Figure 8-8, (1)) on a cooling system tester.



0000577A

Figure 8-8

2. Apply 10.8 - 14.8 psi (75 - 105 kPa; 0.75 - 1.05 kgf/cm²) to the radiator cap. The radiator cap relief valve must open within the specified range.

Reassembly of Engine Coolant Pump

1. Reinstall the thermostat (Figure 8-9, (1)).

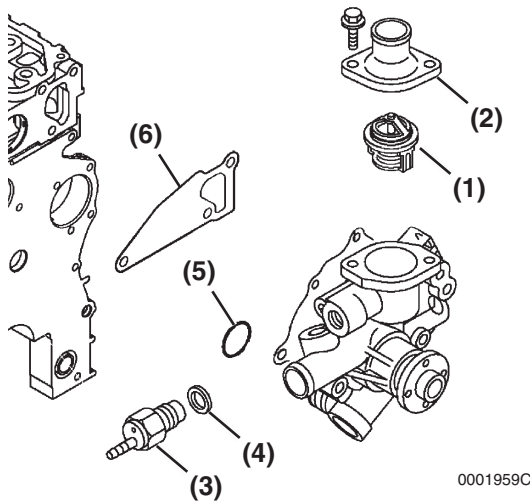

0001959C

Figure 8-9

2. Reinstall the thermostat cover (Figure 8-9, (2)). Tighten the thermostat cover bolts.
3. Reinstall the temperature switch (Figure 8-9, (3)) and a new gasket (Figure 8-9, (4)).
4. Position the engine coolant pump on the engine and install a new gasket (Figure 8-9, (6)). Use a new special O-ring (Figure 8-9, (5)) on assembly between the engine coolant pump and the joint.

CAUTION

Use a new special O-ring between the engine coolant pump and the joint. Be sure to use the special O-ring for each engine model. Although the O-ring dimensions are the same as a commercially available O-ring, the material is different.

0000042en

5. Reinstall the engine coolant pump bolts. Tighten the bolts.
6. Inspect and reinstall the coolant hoses and the temperature switch lead wire.
7. Reinstall the engine coolant pump V-pulley (Figure 8-10, (3)), spacer (Figure 8-10, (2)) engine coolant fan (Figure 8-10, (1)) and engine coolant fan guard (if equipped).

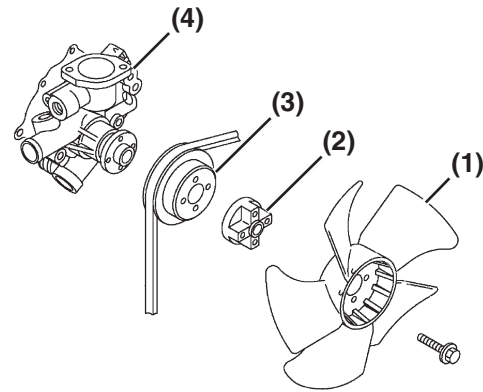

0001959B

Figure 8-10

8. Inspect the condition of the V-belt. There must be clearance (Figure 8-11, (1)) between the V-belt and the bottom of the pulley groove. If there is no clearance (Figure 8-11, (2)) between the V-belt and the bottom of the pulley groove, replace the V-belt.

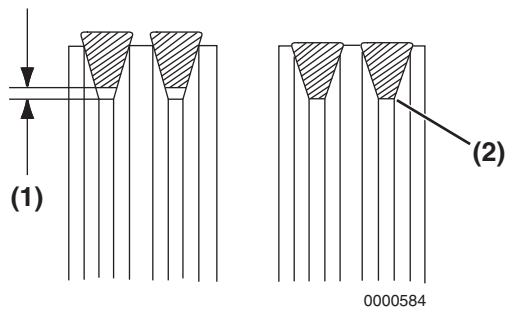

Figure 8-11

9. Reinstall the V-belt. Tighten the V-belt to the proper tension. *See Check and Adjust Cooling Fan V-Belt on page 5-27.*
10. Reinstall and tighten the drain plug or close the drain cock in the radiator. Reinstall and tighten the engine block drain plug or reconnect the coolant hose at the oil cooler.
11. Fill radiator and engine with engine coolant. *See Drain, Flush and Refill Cooling System with New Coolant on page 5-33.*

CAUTION

- **Only use the engine coolant specified. Other engine coolants may affect warranty coverage, cause an internal buildup of rust and scale and / or shorten engine life.**
- **Prevent dirt and debris from contaminating the engine coolant. Carefully clean the radiator cap and the surrounding area before you remove the cap.**
- **NEVER mix different types of engine coolants. This may adversely affect the properties of the engine coolant.**

000006en

Section 9

LUBRICATION SYSTEM

	Page
Before You Begin Servicing	9-3
Introduction.....	9-5
Oil Pump Service Information.....	9-5
Engine Oil Pressure.....	9-5
Outer Rotor Outside Clearance	9-5
Outer Rotor Side Clearance	9-5
Outer Rotor to Inner Rotor Tip Clearance	9-5
Inner Rotor and Gear Boss Clearance	9-6
Lubrication System Diagram	9-7
Checking Engine Oil Pressure	9-8
Trochoid Oil Pump.....	9-8
Oil Pump Components	9-8
Disassembly of Oil Pump	9-9
Cleaning and Inspection	9-10
Reassembly of Oil Pump.....	9-11

This Page Intentionally Left Blank

BEFORE YOU BEGIN SERVICING

CAUTION

<p>NEVER permit anyone to operate the engine or driven machine without proper training.</p> <ul style="list-style-type: none"> • Read and understand this Operation Manual before you operate or service the machine to ensure that you follow safe operating practices and maintenance procedures. • Machine safety signs and labels are additional reminders for safe operating and maintenance techniques. • See your authorized Yanmar industrial engine dealer or distributor for additional training.
<small>000002en</small>

⚠ WARNING

<p style="text-align: center;">ENTANGLEMENT HAZARD!</p> <ul style="list-style-type: none"> • Stop the engine before you begin to service it. • NEVER leave the key in the key switch when you are servicing the engine. Someone may accidentally start the engine and not realize you are servicing it. This could result in a serious injury. • If you must service the engine while it is operating, remove all jewelry, tie back long hair, and keep your hands, other body parts and clothing away from moving / rotating parts. • Failure to comply could result in death or serious injury.
<small>0000010en</small>

⚠ WARNING

<p style="text-align: center;">BURN HAZARD!</p> <ul style="list-style-type: none"> • Keep your hands and other body parts away from hot engine surfaces such as the muffler, exhaust pipe, turbocharger (if equipped) and engine block during operation and shortly after you shut the engine down. These surfaces are extremely hot while the engine is operating and could seriously burn you. • Failure to comply could result in death or serious injury.
<small>0000015en</small>

⚠ WARNING**FUME / BURN HAZARD!**

- Always read and follow safety related precautions found on containers of hazardous substances like parts cleaners, primers, sealants and sealant removers.
- Failure to comply could result in death or serious injury.

0000014en

⚠ CAUTION**FLYING OBJECT HAZARD!**

- ALWAYS wear eye protection when servicing the engine and when using compressed air or high-pressure water. Dust, flying debris, compressed air, pressurized water or steam may injure your eyes.
- Failure to comply may result in minor or moderate injury.

0000003en

CAUTION

- Only use the engine oil specified. Other engine oils may affect warranty coverage, cause internal engine components to seize and / or shorten engine life.
- Prevent dirt and debris from contaminating the engine oil. Carefully clean the oil cap / dipstick and the surrounding area before you remove the cap.
- NEVER mix different types of engine oil. This may adversely affect the lubricating properties of the engine oil.
- NEVER overfill. Overfilling may result in white exhaust smoke, engine overspeed or internal damage.

0000005en

CAUTION

If the oil pump must be replaced, replace it as an assembly only. Do not replace individual components.

0000030en

INTRODUCTION

This section of the *Service Manual* describes the procedures necessary to service the 2TNV70, 3TNV70 and 3TNV76 trochoid oil pumps.

Note: See *Replace Engine Oil and Engine Oil Filter* on page 5-25 for engine oil and engine oil filter replacement procedures.

OIL PUMP SERVICE INFORMATION

Engine Oil Pressure

Model	at Rated Engine rpm	at Low Idle Speed
2TNV70 - VM	42 - 64 psi (0.29 - 0.44 MPa 2.96 - 4.49 kgf/cm ²)	8.8 psi (0.06 MPa; 0.6 kfg/cm ²) or greater
3TNV70 - VH		
3TNV76 - CH		
3TNV70 - CL	35 - 51 psi (0.24 - 0.35 MPa 2.44 - 3.57 kgf/cm ²)	
3TNV76 - CL		

Outer Rotor Outside Clearance

Model	Standard	Limit	Reference Page
2TNV70 3TNV70 3TNV76	0.0047 - 0.0083 in. (0.12 - 0.21 mm)	0.0118 in. (0.30 mm)	<i>Check Outer Rotor Outside Clearance on page 9-10</i>

Outer Rotor Side Clearance

Model	Standard	Limit	Reference Page
2TNV70 3TNV70 3TNV76	0.0008 - 0.0028 in. (0.02 - 0.07 mm)	0.0047 in. (0.12 mm)	<i>Check Outer Rotor Side Clearance on page 9-10</i>

Outer Rotor to Inner Rotor Tip Clearance

Model	Standard	Limit	Reference Page
2TNV70 3TNV70 3TNV76	-	0.0063 in. (0.16 mm)	<i>Outer Rotor to Inner Rotor Tip Clearance on page 9-10</i>

Inner Rotor and Gear Boss Clearance

Item	Parts	Standard Dimension	Standard Clearance	Standard Clearance Limit	Reference Page
Inside Clearance of Inner Rotor	Gear Boss Diameter	2.0886 - 2.0925 in. (53.05 - 53.15 mm)	0.012 - 0.020 in. (0.3 - 0.5 mm)	0.024 in. (0.6 mm)	<i>Check Inner Rotor and Gear Boss Clearance on page 9-11</i>
	Rotor Diameter	2.1043 - 2.1083 in. (53.45 - 53.55 mm)			
Inner Rotor Width Across Flat Clearance	Width Across Flat of Gear Boss	1.9468 - 1.9587 in. (49.45 - 49.75 mm)	0.008 - 0.024 in. (0.2 - 0.6 mm)	0.028 in. (0.7 mm)	
	Width Across Flat of Rotor	1.9665 - 1.9705 in. (49.95 - 50.05 mm)			

LUBRICATION SYSTEM DIAGRAM

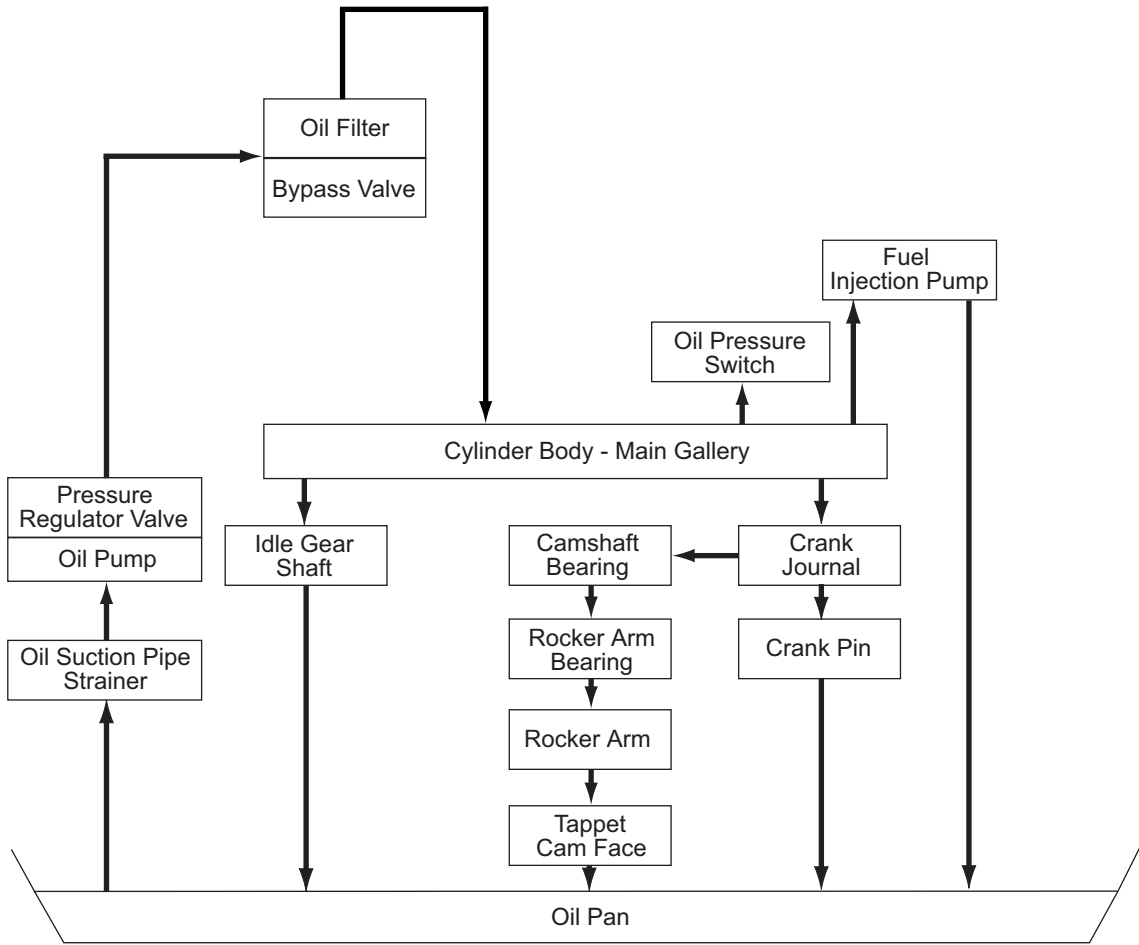

0001624

Figure 9-1

CHECKING ENGINE OIL PRESSURE

Perform an engine oil pressure check if there is any indication of low oil pressure such as the oil pressure indicator is on or the oil pressure gauge indicates low oil pressure. See *Engine Oil Pressure* on page 9-5 for the engine oil pressure specification.

1. Disconnect the wire lead from the oil pressure switch or sending unit (**Figure 9-2, (1)**).

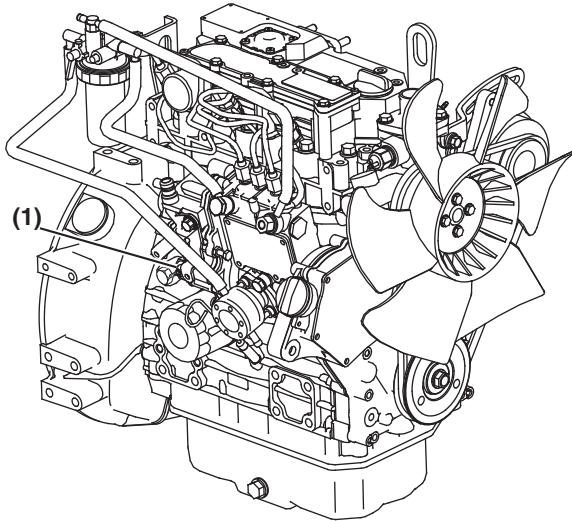

0000020A

Figure 9-2

2. Remove the oil pressure switch.
3. Install a mechanical oil pressure gauge in the oil pressure switch port.
4. Start the engine:
 - If the mechanical oil pressure test gauge indicates good oil pressure, replace the faulty oil pressure switch or sending unit or faulty machine oil pressure gauge in instrument panel.
 - If the mechanical oil pressure test gauge indicates low oil pressure, troubleshoot the lubrication system to locate the cause of the low oil pressure. See *Troubleshooting Charts* on page 13-7. Repair as necessary.

TROCHOID OIL PUMP

Oil Pump Components

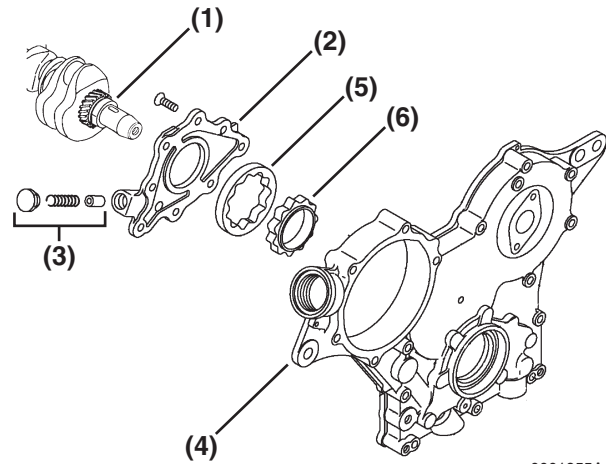

0001955A

- 1 – Crankshaft
- 2 – Oil Pump Cover
- 3 – Oil Pressure Regulator
- 4 – Gear Case Cover
- 5 – Outer Rotor
- 6 – Inner Rotor

Figure 9-3

Disassembly of Oil Pump

CAUTION

If the oil pump must be replaced, replace it as an assembly only. Do not replace individual components.

0000030en

1. Remove the engine cooling fan guard (if equipped), engine cooling fan (**Figure 9-4, (1)**), spacer (**Figure 9-4, (2)**), engine coolant pump V-pulley (**Figure 9-4, (3)**) and V-belt.

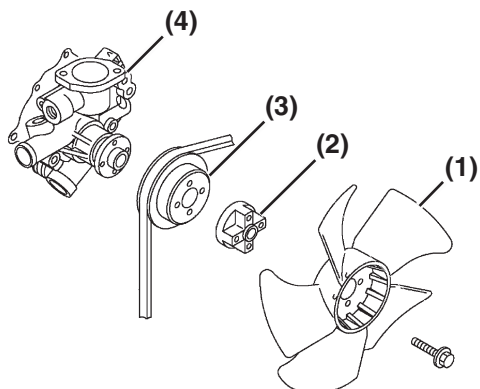

0001959B

Figure 9-4

2. Remove the front crankshaft pulley and gear case cover. See *Removal of Timing Gear Case Cover* on page 6-38.
3. Remove the seven oil pump cover screws (**Figure 9-5, (2)**).

Note: The oil pump cover screws are installed using a liquid thread lock. It may be necessary to use "localized heat" (small propane torch) and an impact-type screwdriver to remove these screws.

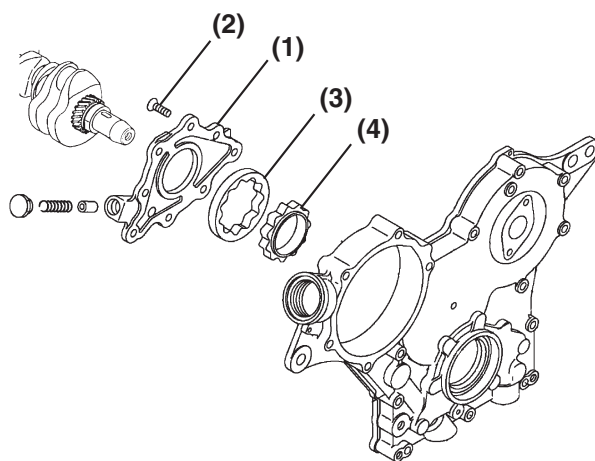

0001955B

Figure 9-5

4. Remove the oil pump cover (**Figure 9-5, (1)**) from the gear case.
5. Remove the outer rotor (**Figure 9-5, (3)**) and inner rotor (**Figure 9-5, (4)**) from the gear case cover.
6. Remove the oil pressure regulator valve (**Figure 9-6, (1)**) from the oil pump cover (**Figure 9-6, (2)**).

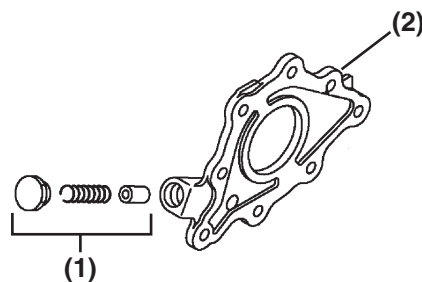

0001958A

Figure 9-6

Cleaning and Inspection

Wash the oil pump cover, the oil pressure regulator valve, the oil pump cavity and the inner and outer rotors. Inspect the parts for wear or damage. Replace as necessary.

Note: If the oil pump cavity is damaged, the gear case cover must be replaced.

CAUTION

If any oil pump component clearance exceeds its limit, the oil pump must be replaced as an assembly.

0000015en

Check Outer Rotor Outside Clearance

1. Reinstall the outer and inner rotors. The dots on the rotor faces must face "up." Make sure that the pilot on the back of the inner rotor fits into the bore of the oil pump cavity and the top surface of the inner rotor is flush with the top surface of the outer rotor.
2. Determine the outside clearance of the outer rotor. Insert a feeler gauge between the outer rotor (Figure 9-7, (1)) and the gear case oil pump cavity (Figure 9-7, (2)).



0001151A

Figure 9-7

Record the measurement. See *Outer Rotor Outside Clearance* on page 9-5 for the service limit.

Outer Rotor to Inner Rotor Tip Clearance

Determine the outer rotor to inner rotor tip clearance. Insert a feeler gauge between the top of an inner rotor tooth (Figure 9-8, (1)) and the top of an outer rotor tooth (Figure 9-8, (2)) and measure the clearance.

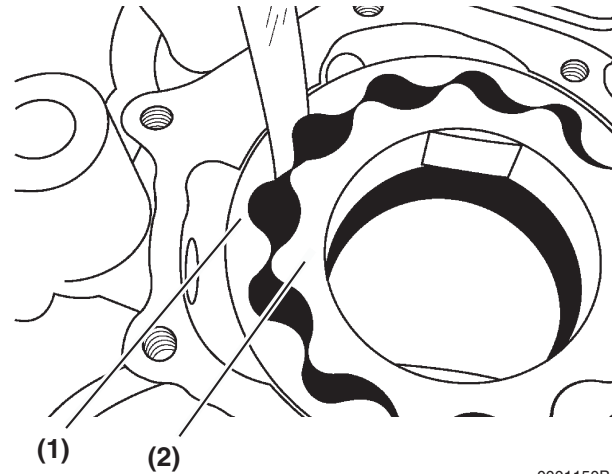

0001150B

Figure 9-8

Record the measurement. See *Outer Rotor to Inner Rotor Tip Clearance* on page 9-5 for the service limit.

Check Outer Rotor Side Clearance

Determine the side clearance of the outer rotor across the pump cavity. While pressing down on the outer rotor, measure the depression using a depth micrometer (Figure 9-9).

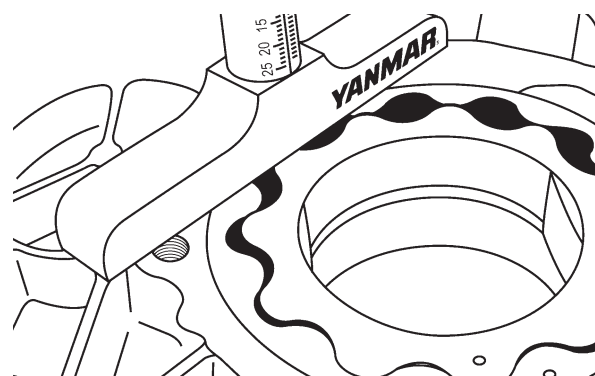
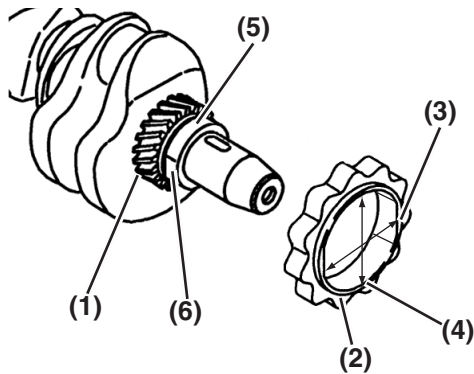

Figure 9-9

Record the measurement. See *Outer Rotor Side Clearance* on page 9-5 for the service limit.

Check Inner Rotor and Gear Boss Clearance



- 1 – Crank Gear
- 2 – Inner Rotor
- 3 – Inside Width Across Flats of Inner Rotor
- 4 – Overall Inside Diameter of Inner Rotor
- 5 – Overall Inside Diameter of Gear Boss
- 6 – Outside Width Across Flats of Gear Boss

Figure 9-10

Record the measurement. See *Inner Rotor and Gear Boss Clearance* on page 9-6 for service limits.

Reassembly of Oil Pump

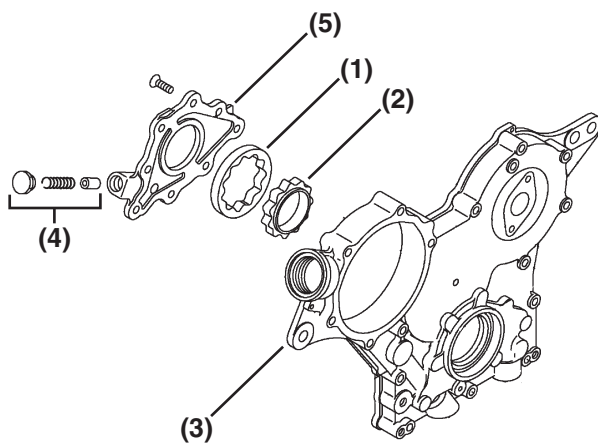

Figure 9-11

1. Lubricate the outer rotor (**Figure 9-11, (1)**), inner rotor (**Figure 9-11, (2)**) and pump bore in the gear case cover (**Figure 9-11, (3)**) with clean engine oil.

2. Reinstall the outer rotor in the gear case. The dot mark on the face of the outer rotor must face up toward the oil pump cover.
3. Reinstall the inner rotor into the gear case cover with the dot mark also facing up. Make sure that the pilot on the back side of the inner rotor fits into the bore in the gear case cover and the top surface of the inner rotor is flush with the top surface of the outer rotor.
4. Reinstall the oil pressure regulator valve (**Figure 9-11, (4)**) into the oil pump cover (**Figure 9-11, (5)**). Apply LOCTITE® 242 (red) to the valve plug, following the manufacturer's instructions.
5. Reinstall the oil pump cover (**Figure 9-11, (5)**). Apply LOCTITE 290 (green) or LOCTITE 262 (red) to the oil pump cover screws. Tighten the pump cover screws to 52 - 70 in-lb (5.9 - 7.9 N·m, 0.6 - 7.9 kgf·m).
6. Reinstall the crankshaft pulley and gear case cover. See *Removal of Timing Gear Case Cover* on page 6-38.
7. Reinstall the engine coolant pump V-pulley (**Figure 9-12, (3)**), spacer (**Figure 9-12, (2)**), engine cooling fan (**Figure 9-12, (1)**) and engine cooling fan guard (if equipped).

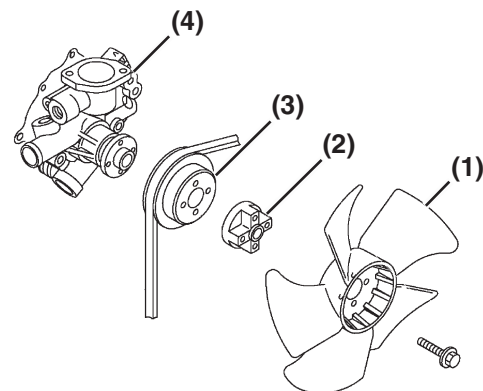

Figure 9-12

8. Reinstall the V-belt. Tighten the V-belt to the proper tension. See *Check and Adjust Cooling Fan V-Belt* on page 5-27.

This Page Intentionally Left Blank

Section 10

STARTER MOTOR

	Page
Before You Begin Servicing	10-3
Introduction.....	10-5
Starter Motor Information	10-5
Starter Motor Specifications	10-6
Starter Motor Troubleshooting.....	10-7
Starter Motor Components	10-8
Starter Motor	10-9
Removal of Starter Motor	10-10
Disassembly of Starter Motor	10-10
Cleaning and Inspection	10-12
Reassembly of Starter Motor.....	10-17
Check Pinion Projection Length	10-19
No-Load Test.....	10-19
Installation of Starter Motor	10-20

This Page Intentionally Left Blank

BEFORE YOU BEGIN SERVICING

⚠ WARNING

<p>ENTANGLEMENT HAZARD!</p> <ul style="list-style-type: none"> • Stop the engine before you begin to service it. • NEVER leave the key in the key switch when you are servicing the engine. Someone may accidentally start the engine and not realize you are servicing it. This could result in a serious injury. • If you must service the engine while it is operating, remove all jewelry, tie back long hair, and keep your hands, other body parts and clothing away from moving / rotating parts. • Failure to comply could result in death or serious injury. <p style="text-align: right; font-size: small;">0000010en</p>

⚠ WARNING

<p>SHOCK HAZARD!</p> <ul style="list-style-type: none"> • Turn off the battery switch (if equipped) or disconnect the negative battery cable before servicing the electrical system. • Check the electrical harnesses for cracks, abrasions, and damaged or corroded connectors. ALWAYS keep the connectors and terminals clean. • Failure to comply could result in death or serious injury. <p style="text-align: right; font-size: small;">0000009en</p>

⚠ WARNING

<p>FUME / BURN HAZARD!</p> <ul style="list-style-type: none"> • Always read and follow safety related precautions found on containers of hazardous substances like parts cleaners, primers, sealants and sealant removers. • Failure to comply could result in death or serious injury. <p style="text-align: right; font-size: small;">0000014en</p>

CAUTION**FLYING OBJECT HAZARD!**

- **ALWAYS** wear eye protection when servicing the engine and when using compressed air or high-pressure water. Dust, flying debris, compressed air, pressurized water or steam may injure your eyes.
- Failure to comply may result in minor or moderate injury.

000003en

CAUTION

The starter motor is water-proofed according to JIS D 0203, R2 which protects the motor from rain or general cleaning. Do not use high-pressure wash or submerge the starter motor in water.

0000055en

CAUTION

Use a specialized battery charger to recharge a battery with a voltage of 8 volts or less. Booster starting a battery with a voltage of 8 volts or less will generate an abnormally high voltage and destroy electrical equipment.

0000056en

CAUTION

The starter motor can be damaged if operated continuously longer than 10 seconds while performing the no-load test.

0000034en

CAUTION

Make sure that the combined total resistance of the battery cable in both directions between the starter motor and the battery is within the value indicated on the wiring diagram. The starter motor will malfunction or break down if the resistance is higher than the specified value.

0000054en

INTRODUCTION

This section of the *Service Manual* covers the servicing of starter motor. Yanmar Part No. 119717-77010 is standard equipment on 3TNV76 model engines and is used in this section to show the service procedures for a representative starter motor. For specific part detail, see the *Yanmar Parts Catalog* for the engine being serviced.

STARTER MOTOR INFORMATION

YANMAR Part Number	Mfg.	Mfg. Model Number	Specification	No Load			Loaded			
				Terminal Voltage	Amperage Draw	RPM	Terminal Voltage	Amperage Draw	Torque	RPM
119515-77010	Denso	428000-2190	DC12V -1.3 hp (1.0 kW)	11.5	90A (Max)	3000 (Min)	8.0	200 (Max)	42 in.-lb (4.7 N·m; 0.48 kgf·m)	1240 (Min)
119717-77010	Denso	428000-1590	DC12V -1.5 hp (1.1 kW)	11.5	90A (Max)	3000 (Min)	8.7	230 (Max)	61 in.-lb (6.9 N·m; 0.70 kgf·m)	1130 (Min)
119740-77010	Denso	428000-3310	DC12V -1.9 hp (1.4 kW)	11.5	90A (Max)	3000 (Min)	8.5	350 (Max)	119 in.-lb (13.5 N·m; 1.38 kgf·m)	1000 (Min)

STARTER MOTOR SPECIFICATIONS

Yanmar Part Number		119717-77010	119515-77010
Nominal Output		1.5 hp (1.1 kW)	1.34 hp (1.0 kW)
Weight		6.6 lb (3.0 kg)	6.3 lb (2.85 kg)
Revolution Direction (As Viewed From Pinion)		Clockwise	Clockwise
Engagement System		Magnetic Shift	Magnetic Shift
No-load	Terminal Voltage/Current	11.5 V / 90 A max	11.5 V / 90 A max
	Revolution	3000 rpm (min ⁻¹)	3000 rpm (min ⁻¹)
Loaded	Terminal Voltage/Current	8.7 V / 230 A	8.0 V / 230 A
	Torque	61 in·lb (6.9 N·m; 0.70 kgf·m)	41.7 in·lb (4.7 N·m; 0.48 kgf·m)
	Revolution	1130 rpm (min)	1240 rpm (min)
Stalled	Terminal Voltage/Current	2.5 V / 325 A max	2.5 V / 260 A max
	Torque	73 in·lb (8.24 N·m; 0.84 kgf·m) minimum	43.5 in·lb (4.9 N·m; 0.5 kgf·m) minimum
Clutch System		Overrunning	Overrunning
Pinion Projection Voltage at 212°F (100 °C)		8.0 V max	8.0 V max
Pinion DP or Module/Number of Teeth		M2.54/9	M2.54/9
Application		Standard	Standard
Brush	Spring Force		3.1 - 4.0 lbf (13.7 - 17.6 N; 1.4 - 1.8 kgf)
	Length	Standard	0.55 in. (14 mm)
		Service Limit	0.44 in. (11.1 mm)
Solenoid Switch	Pull-In Coil Resistance	0.484 W at 68°F (20°C)	0.484 W at 68°F (20°C)
	Hold-In Coil Resistance	1.055 W at 68°F (20°C)	1.055 W at 68°F (20°C)
Commutator	Outside Diameter	Standard	1.102 in. (28.0 mm)
		Service Limit	1.063 in. (27.0 mm)
	Run-Out	Standard	0.001 in. (0.02 mm)
		Service Limit	0.002 in. (0.05 mm)
	Insulation Depth	Standard	0.024 in. (0.6 mm)
		Service Limit	0.008 in. (0.2 mm)

STARTER MOTOR TROUBLESHOOTING

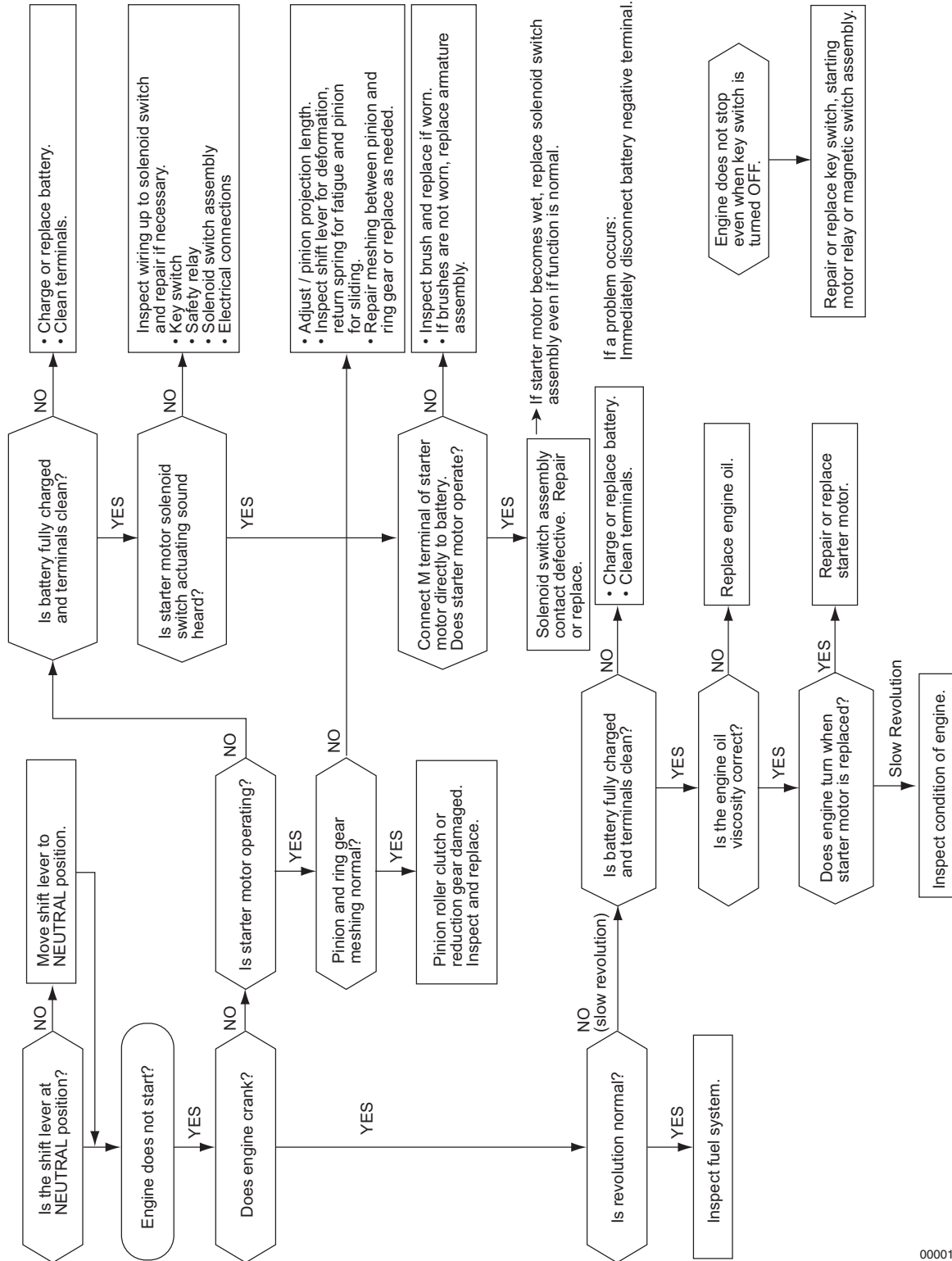

0000102

STARTER MOTOR COMPONENTS

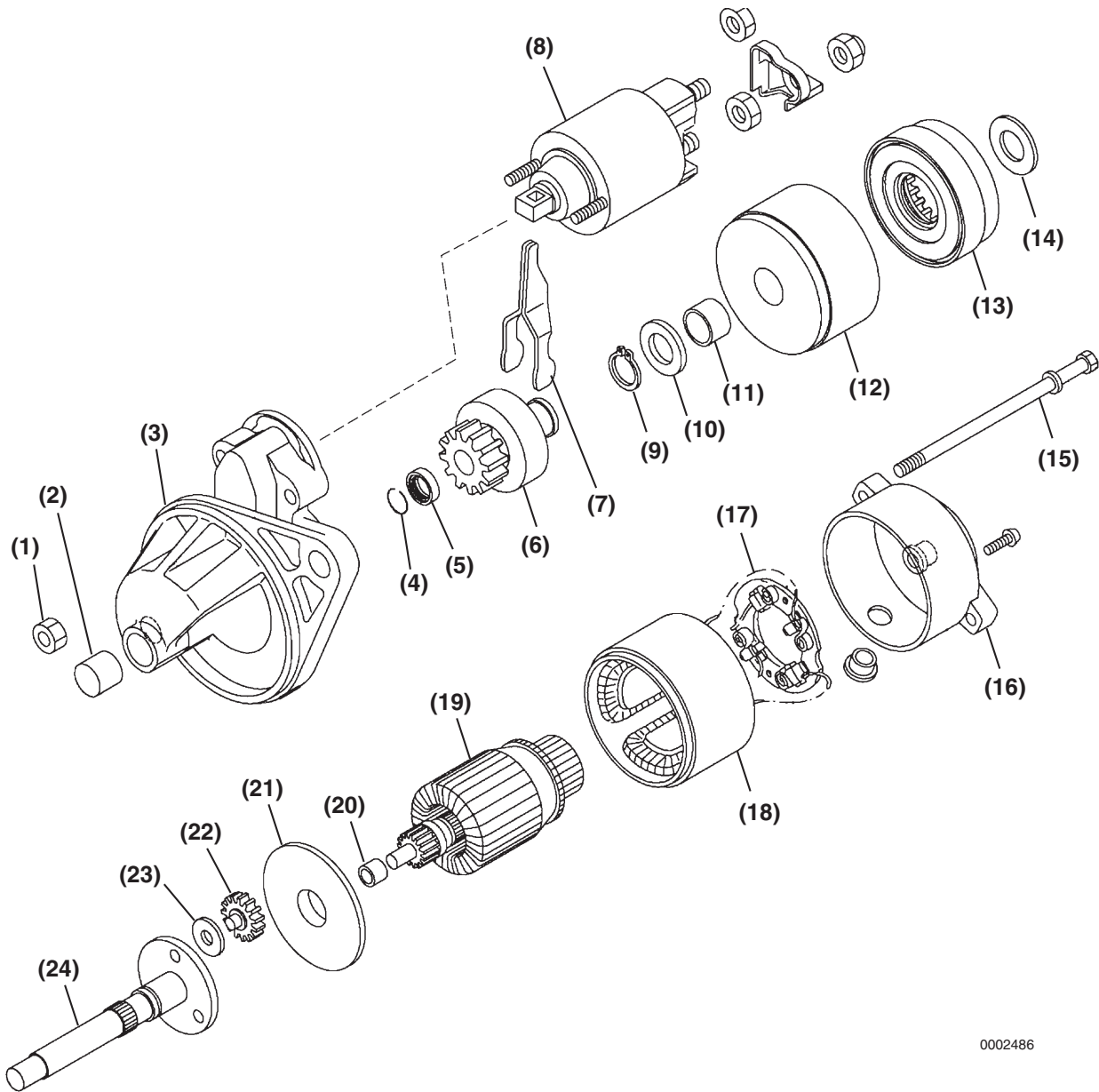

0002486

Figure 10-1

- 1 – Nut
- 2 – Needle Bearing
- 3 – Pinion Housing
- 4 – Pinion Retaining Ring
- 5 – Pinion Stop
- 6 – Pinion
- 7 – Shift Lever
- 8 – Solenoid Switch Assembly
- 9 – Snap Ring
- 10 – Washer
- 11 – Bushing
- 12 – Intermediate Housing
- 13 – Reduction Gear
- 14 – Washer
- 15 – Through Bolt
- 16 – End Housing
- 17 – Brush Plate and Holder
- 18 – Field Assembly
- 19 – Armature
- 20 – Bushing
- 21 – Plate
- 22 – Planetary Gear (3 used)
- 23 – Washer (3 used)
- 24 – Pinion Shaft

STARTER MOTOR

WARNING



SHOCK HAZARD!

- Turn off the battery switch (if equipped) or disconnect the negative battery cable before servicing the electrical system.
- Check the electrical harnesses for cracks, abrasions, and damaged or corroded connectors. ALWAYS keep the connectors and terminals clean.
- Failure to comply could result in death or serious injury.

000009en

Note: While starter motor design varies between models, the basic repair procedures are the same. The following procedures are typical and may differ from the starter being serviced.

Removal of Starter Motor

1. Disconnect the battery cables at the battery, negative (-) cable first.
2. Remove the electrical wires from the solenoid switch assembly.
3. Remove the starter mounting bolts (Figure 10-2, (1)). Remove the starter motor from the flywheel housing.

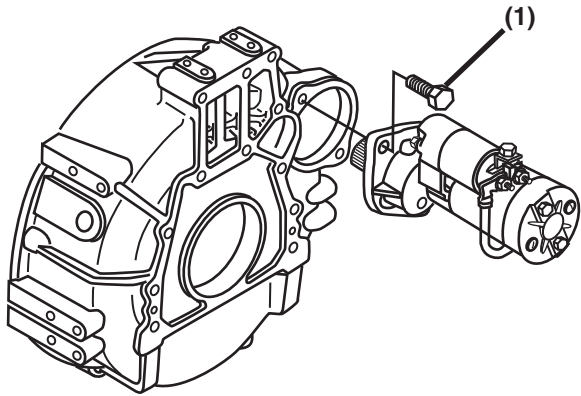

Figure 10-2

0002126

Disassembly of Starter Motor

1. Make alignment marks across all mating joints.
2. Disconnect the field wire from the solenoid switch (Figure 10-3).

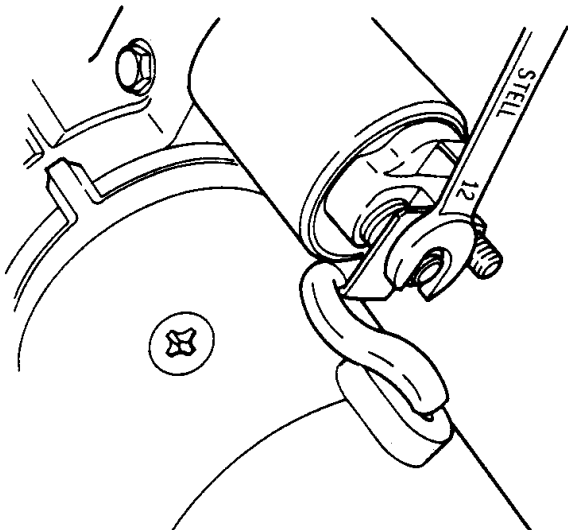
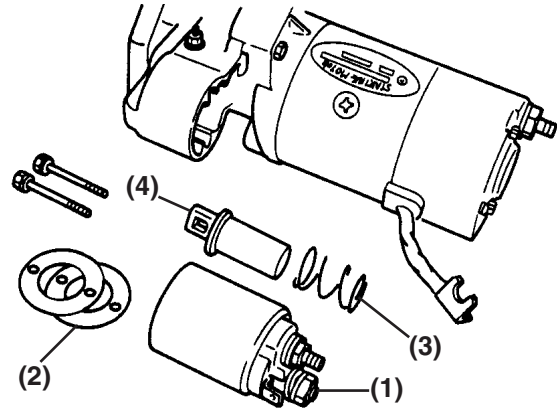

Figure 10-3

0000138

3. Remove the two bolts or nuts retaining the solenoid switch assembly (Figure 10-4, (1)) to the pinion housing. Remove the solenoid switch assembly and dust covers (Figure 10-4, (2)). Remove the plunger (Figure 10-4, (4)) and torsion spring (Figure 10-4, (3)) from the pinion housing.



0000140A

Figure 10-4

4. Remove the two bolts (Figure 10-5, (1)) securing the rear cover (Figure 10-5, (2)) to the brush holder assembly (Figure 10-5, (3)).

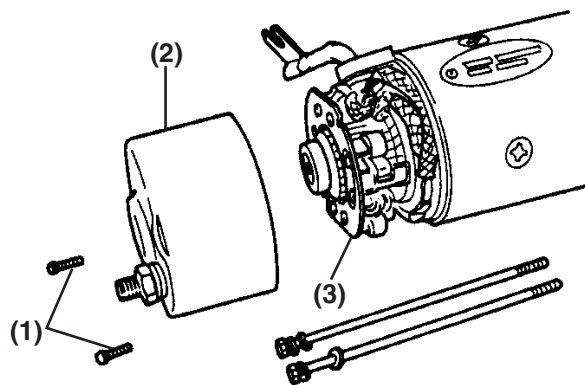

0000142A

Figure 10-5

5. Remove the two through bolts. Remove the rear cover (Figure 10-5, (2)).

- Pull the brush springs up using a brush spring puller. On the negative (-) side, bring the brush spring into contact with the side of the brushes to hold the brushes clear of the commutator surface. On the positive (+) side, remove the brushes from the brush holder assembly (Figure 10-6).

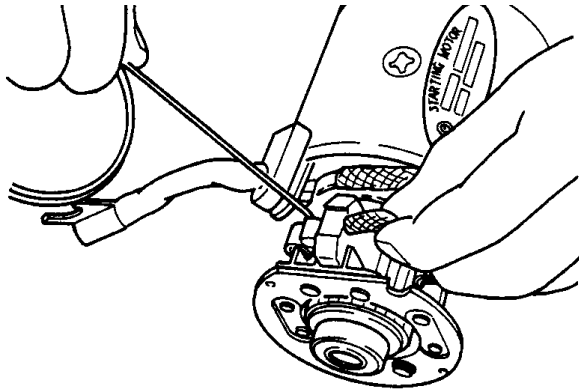

0000143

Figure 10-6

- Remove the brush plate and holder (Figure 10-7, (1)).

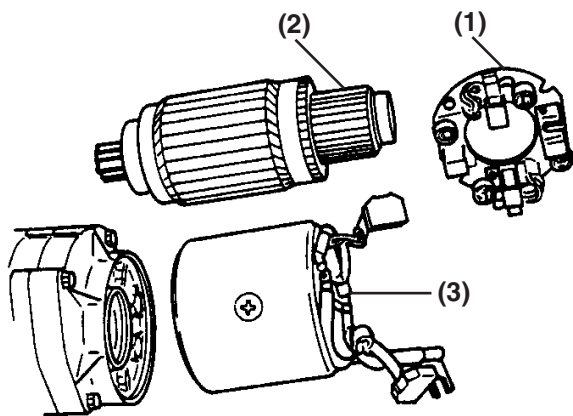

0000144A

Figure 10-7

- Pull the field assembly (Figure 10-7, (3)) off from the armature assembly (Figure 10-7, (2)).
- Remove the armature from the intermediate housing.
- Remove the intermediate housing, gear and pinion shaft assembly (Figure 10-8, (4)) from the pinion housing (Figure 10-8, (3)). Disengage from the shift lever as it is removed.

- Remove the shift lever (Figure 10-8, (2)), pin, and spacer (Figure 10-8, (1)).

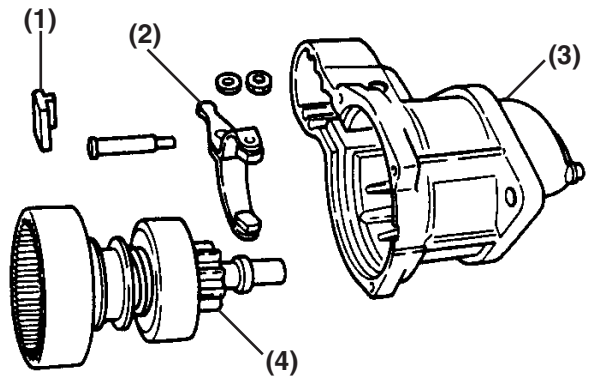

0000148A

Figure 10-8

- Pull the pinion stop (Figure 10-9, (1)) down to expose the retaining ring. Using a flat-blade screwdriver, remove the retaining ring (Figure 10-9, (2)) from the pinion shaft.

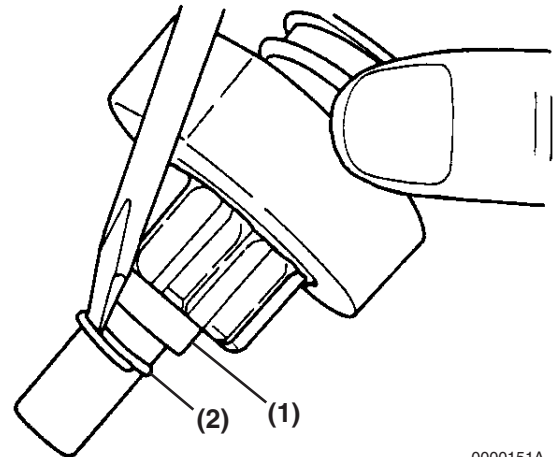

0000151A

Figure 10-9

13. Remove the pinion stop (**Figure 10-10, (3)**), return spring (if equipped), and pinion clutch assembly (**Figure 10-10, (2)**), from the pinion shaft (**Figure 10-10, (1)**).

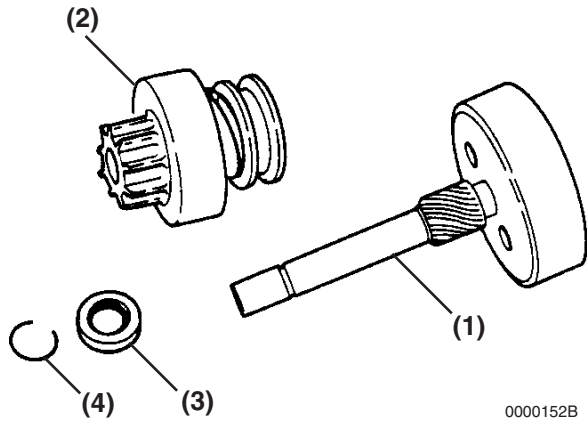

Figure 10-10

14. Remove the snap ring (**Figure 10-11, (1)**). Remove the pinion shaft (**Figure 10-11, (5)**), planetary gears (**Figure 10-11, (6)**), washers, and reduction gear (**Figure 10-11, (4)**) from the intermediate housing (**Figure 10-11, (3)**).

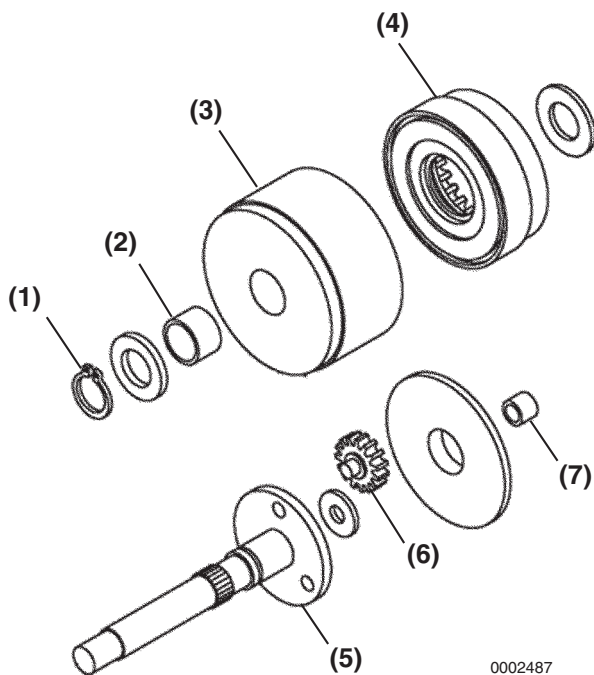

Figure 10-11

15. Inspect the intermediate bushing (**Figure 10-11, (2)**) and replace if worn or damaged.
16. Inspect armature bushing (**Figure 10-11, (7)**) and replace if worn or damaged.

Cleaning and Inspection

Armature

Commutator Surface Inspection

If the commutator surface is rough, polish the surface with a #500 to #600 emery cloth.

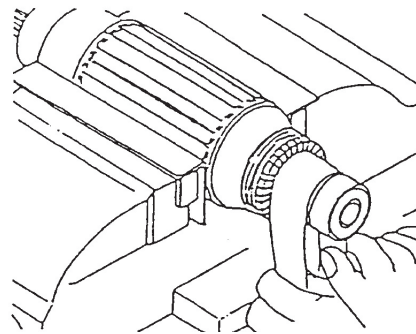

Figure 10-12

Measure Commutator Outside Diameter

Measure the commutator outside diameter. Replace the armature if the measurement is less than the limit. See *Starter Motor Specifications* on page 10-6.

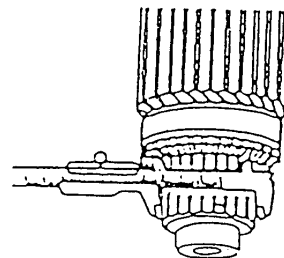
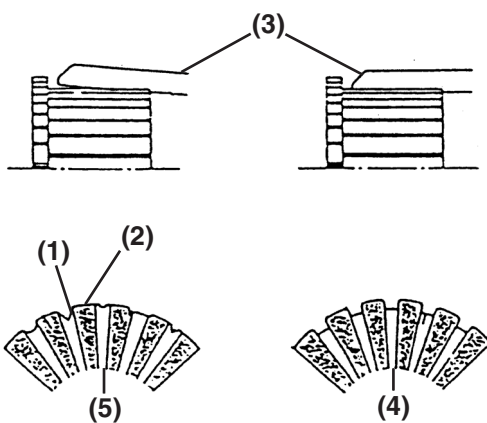

Figure 10-13

Measure Commutator Insulation Depth

Measure the depth of the insulating material (Figure 10-14, (1)) between commutator segments (Figure 10-14, (2)). If the depth measures less than the limit, use a hacksaw blade (Figure 10-14, (3)) to remove the insulating material until the depth is within the limit. See Starter Motor Specifications on page 10-6 for service limit.

A normal commutator condition is indicated in (Figure 10-14, (4)). An abnormal commutator condition is indicated in (Figure 10-14, (5)).



0000118

Figure 10-14

Armature Coil Continuity Test

Check for continuity between the commutator segments using a multimeter (Figure 10-15). The multimeter should indicate continuity.

If the multimeter does not indicate continuity, replace the armature.

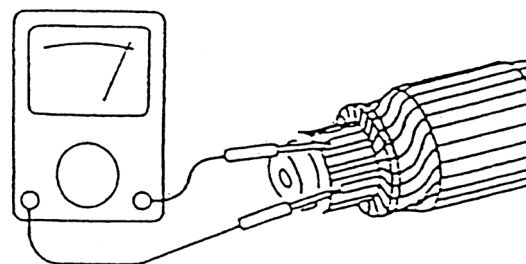

0000114

Figure 10-15

Armature Coil Insulation Test

Check for continuity between a commutator segment and the shaft or armature using a multimeter (Figure 10-16). The multimeter should not indicate continuity.

If the multimeter indicates continuity, replace the armature.

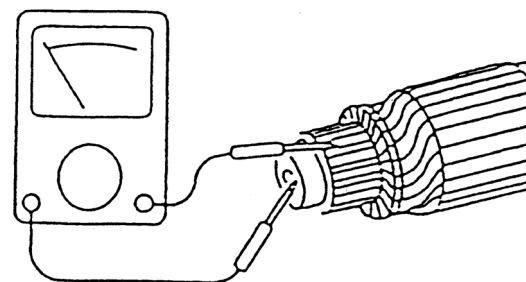

0000115

Figure 10-16

Measure Armature and Commutator Run-Out

Measure the armature core run-out and the commutator run-out using a dial indicator (Figure 10-17). Replace the armature if either of the measurements is not within specifications. See *Starter Motor Specifications on page 10-6 for service limit.*

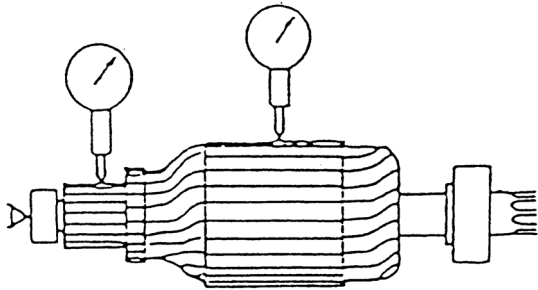

0000116

Figure 10-17

Field Coil

Field Coil Continuity Test

Check for continuity between the field coil terminals using a multimeter (Figure 10-18). The multimeter should indicate continuity.

If the multimeter does not indicate continuity, replace the field coil assembly.

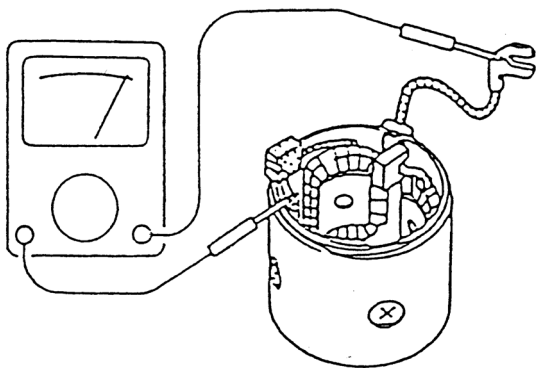

0000119

Figure 10-18

Field Coil Insulation Test

Check for continuity between either field coil terminal and the yoke using a multimeter (Figure 10-19). The multimeter should not indicate continuity.

If the multimeter indicates continuity, replace the field coil assembly.

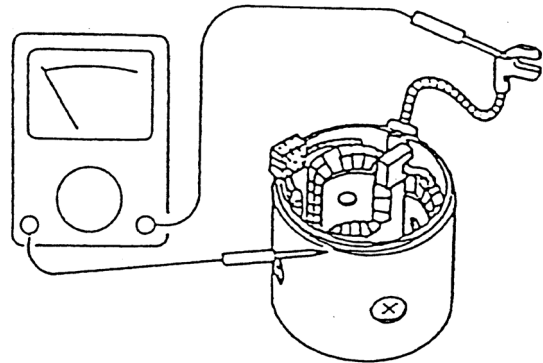

0000120

Figure 10-19

Measure Brush Length

Measure the length of the brush (Figure 10-20). Replace the brush if the length is less than the limit. See *Starter Motor Specifications on page 10-6 for service limit.*

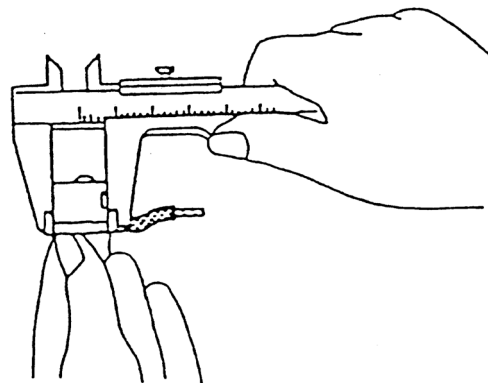

0000121

Figure 10-20

Brush Holder

Brush Holder Insulation Test

Check for continuity between each brush holder and the base using a multimeter (**Figure 10-21**). The multimeter should not indicate continuity.

If the multimeter indicates continuity, replace the brush holder.

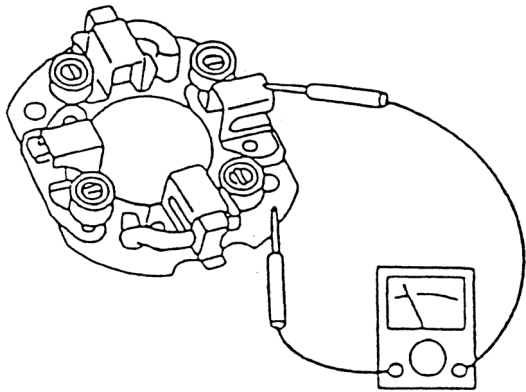

0000122

Figure 10-21

Brush Spring Test

Test the spring force for each brush spring (**Figure 10-22**). Replace the brush spring if the force is not within the range. See *Starter Motor Specifications on page 10-6 for the service limit.*

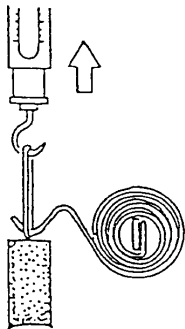

0000123

Figure 10-22

Solenoid Switch

If the starter motor becomes wet, replace the solenoid switch even if the solenoid switch assembly function is normal.

Shunt Coil Continuity Test

Check for continuity between the “S” terminal and the switch body using a multimeter (**Figure 10-23**). The multimeter should indicate continuity.

If the multimeter does not indicate continuity, replace the solenoid switch.

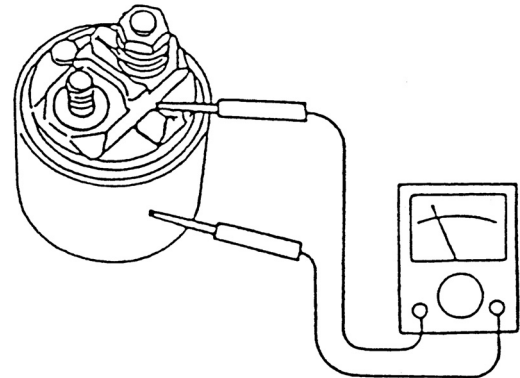

0000124

Figure 10-23

Series Coil Continuity Test

Check for continuity between the “S” and “M” terminals using a multimeter (**Figure 10-24**). The multimeter should indicate continuity.

If the multimeter does not indicate continuity, replace the solenoid switch.

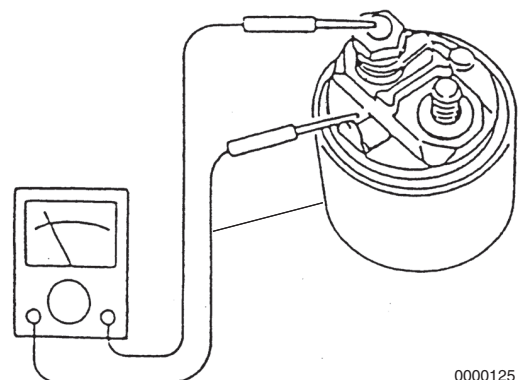

0000125

Figure 10-24

Coil Resistance Test

See Starter Motor Specifications on page 10-6 for service limit.

Contact Continuity Test

Depress the plunger at the bottom of the solenoid switch. Check for continuity between the "B" and "M" terminals using a multimeter (**Figure 10-25**). The multimeter should indicate continuity.

If the multimeter does not indicate continuity, replace the solenoid switch.

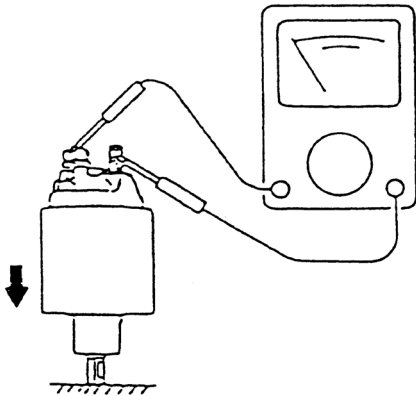

0000126

Figure 10-25**Pinion Clutch Assembly****Pinion Clutch Assembly Inspection**

Manually rotate the pinion clutch assembly in the drive direction. It should rotate freely in the drive direction and is locked by turning it in the opposite direction (**Figure 10-26**). Replace the pinion clutch assembly if the results are different.

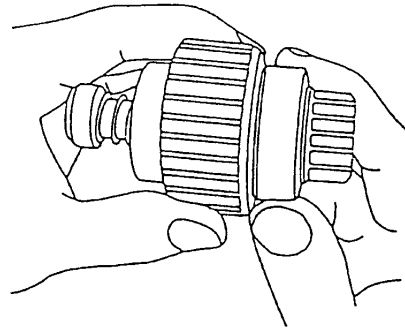

0000127

Figure 10-26

Slide the pinion clutch assembly on the shaft (**Figure 10-27**). It should slide smoothly on the shaft. Rust, too much grease, or damage could prevent the pinion clutch from sliding smoothly. If the pinion clutch assembly does not slide smoothly, clean the shaft and pinion clutch assembly or replace the damaged component.

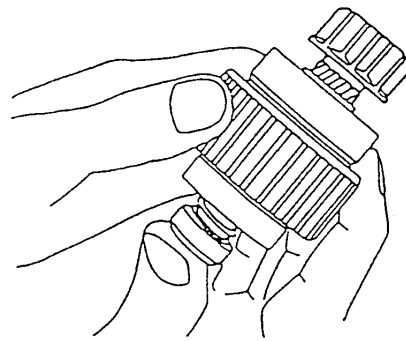

0000128

Figure 10-27

Reassembly of Starter Motor

1. Apply a appropriate starter bendix grease (obtain locally) to the pinion shaft.
2. Reassemble the reduction gear (**Figure 10-28, (4)**), pinion shaft (**Figure 10-28, (5)**), planetary gears (**Figure 10-28, (6)**), and washers into the intermediate housing (**Figure 10-28, (3)**). Reinstall snap ring (**Figure 10-28, (1)**).

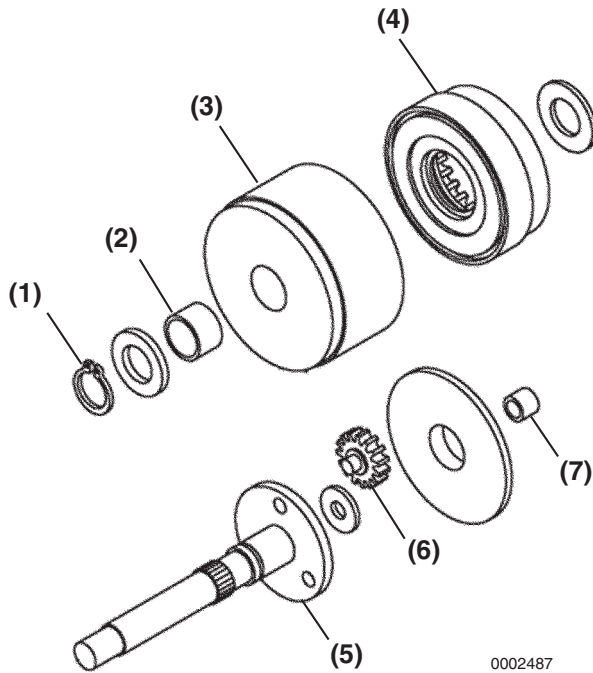

Figure 10-28

3. Reinstall the pinion clutch assembly (**Figure 10-29, (2)**), return spring (if equipped) and pinion stop (**Figure 10-29, (3)**) onto the pinion shaft (**Figure 10-29, (1)**). Reinstall the retaining ring (**Figure 10-29, (4)**) in the groove in the pinion shaft. Slide the pinion stop over the retaining ring.

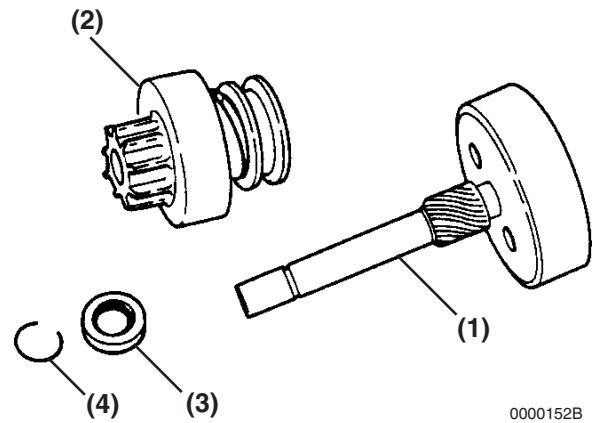

Figure 10-29

4. Apply a small amount of high temperature lithium grease (obtain locally) to the contact surfaces of the shift lever. Reassemble the shift lever (**Figure 10-30, (2)**), spacer (if equipped) (**Figure 10-30, (1)**), and pin.
5. Reinstall the pinion shaft assembly (**Figure 10-30, (4)**) in the pinion housing (**Figure 10-30, (3)**). Be sure the shift lever properly engages the pinion.

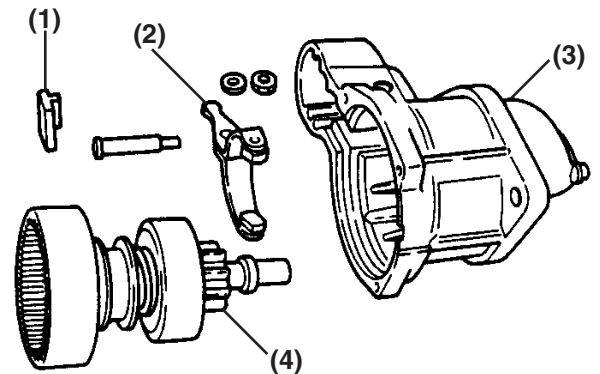
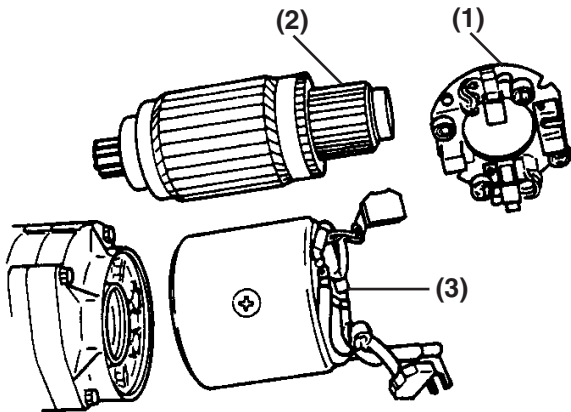

Figure 10-30

6. Apply a small amount of high temperature lithium grease (obtain locally) to the surface of the plunger and the hole that engages the shift lever.
7. Attach the plunger to the shift lever.

- Reinstall the plate onto the intermediate housing and carefully reinstall the armature assembly (**Figure 10-31, (2)**) into the pinion shaft assembly.



0000144A

Figure 10-31

- Reinstall the field assembly (**Figure 10-31, (3)**) over the armature assembly and align to the pinion housing.
- Position the brush springs in brush holders. Reinstall the brushes in the brush holders. Reversing the brushes will cause the starter motor to turn backwards.
- Carefully reinstall the brush holder (**Figure 10-32, (3)**) assembly.
- Reinstall the rear cover (**Figure 10-32, (2)**) and secure with two bolts (**Figure 10-32, (1)**).

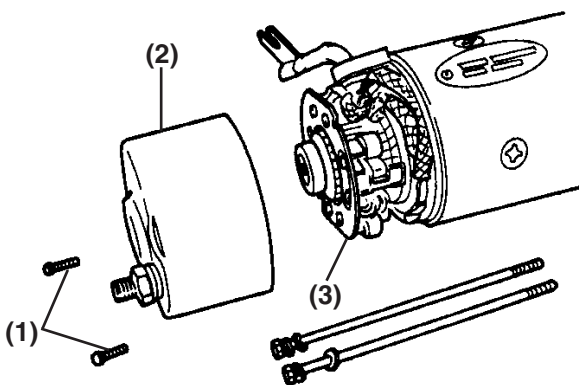

0000142A

Figure 10-32

- Reinstall the two through bolts and tighten securely.
- Reinstall the return spring (if equipped) (**Figure 10-33, (3)**) on the solenoid plunger (**Figure 10-33, (4)**). Reinstall the solenoid switch coil (**Figure 10-33, (1)**) and dust covers (**Figure 10-33, (2)**). Secure with nuts or bolts.

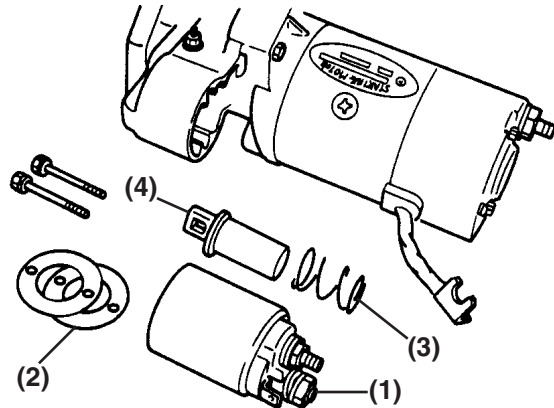

0000140A

Figure 10-33

- Reconnect the wire to the solenoid switch assembly. Tighten the nut. Reinstall the cover over the connection.

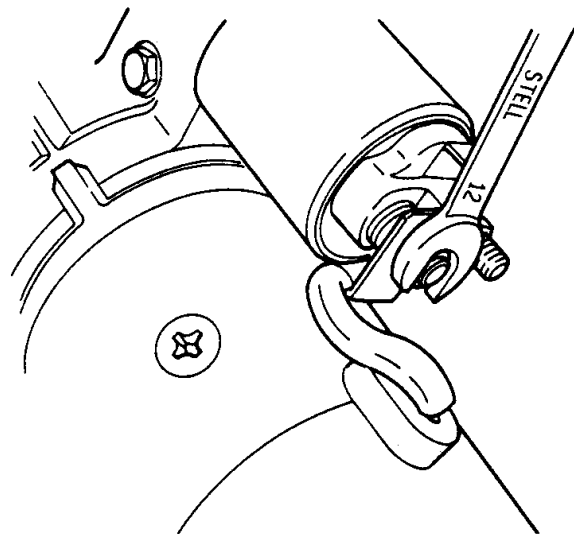

000013:

Figure 10-34

Check Pinion Projection Length

1. Connect the positive (+) lead from a battery to the "S" terminal.
2. Connect the negative (-) lead to the "M" terminal.
3. Lightly pull the pinion away from the gear housing.
4. Turn the switch ON and measure the pinion moving distance L in the thrust direction (**Figure 10-35**). Perform this test within 10 seconds.

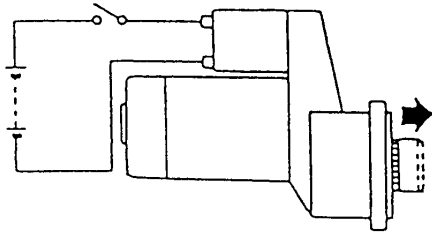

0000132

Figure 10-35

See Starter Motor Specifications on page 10-6 for service limit.

5. If the measured L dimension is outside the standard range, adjust the dust covers to obtain the standard range. Dust covers (**Figure 10-36, (1)**) are available in 0.020 in. (0.5 mm) and 0.031 in. (0.8 mm) thicknesses.

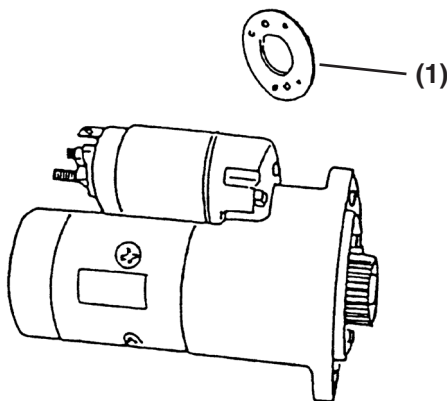

0000133

Figure 10-36

No-Load Test

Test the characteristics of the starter motor by performing a no load test.

CAUTION

The starter motor can be damaged if operated continuously longer than 10 seconds while performing the no-load test.

0000034en

1. Secure the starting motor in a vise or other suitable fixture.
2. Connect an ammeter (**Figure 10-37, (1)**) in series between the battery positive (+) terminal (**Figure 10-37, (2)**) and the main positive (+) terminal (**Figure 10-37, (3)**) on the starter motor.

Note: The ammeter and all wire leads used in this test must have a capacity equal to or greater than the amperage draw specification for the starter motor being tested.

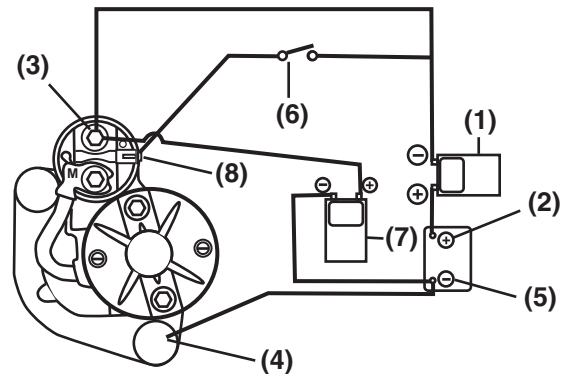

0002127A

Figure 10-37

3. Connect a wire lead between the mounting base of the starter motor (**Figure 10-37, (4)**) and the battery negative terminal (**Figure 10-37, (5)**).
4. Connect a voltmeter (**Figure 10-37, (7)**) to the battery negative (-) terminal (**Figure 10-37, (5)**) and the main positive (+) battery terminal (**Figure 10-37, (3)**) on the starter motor.

5. Install a switch (**Figure 10-37, (6)**) in a circuit between the battery positive (+) terminal (**Figure 10-37, (2)**) and the starter solenoid switch terminal (**Figure 10-37, (8)**) on the starter motor.
6. Use a suitable tachometer to monitor the rpm of the starter.
7. Turn the switch to the ON position to energize the solenoid and operate the starter. Monitor the rpm, amperage draw and voltage. For test specifications, see *Starter Motor Information on page 10-5* for the appropriate starter motor.

Installation of Starter Motor

1. Reinstall the starter motor to the flywheel housing.
2. Reinstall the starter mounting bolts (**Figure 10-38, (1)**). Tighten the bolts to specification. See *Tightening Torques for Standard Bolts and Nuts on page 4-24*.

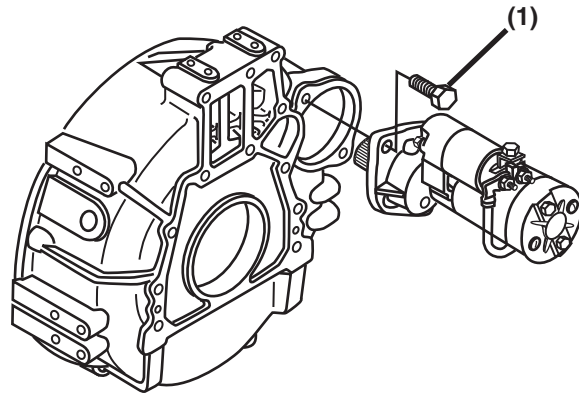

0002126

Figure 10-38

3. Reconnect the electrical wires to the solenoid switch assembly. Be sure to place the cover over the battery positive (+) cable connection.
4. Reconnect the battery, negative (-) cable last.

Section 11

ALTERNATOR

	Page
Before You Begin Servicing	11-3
Introduction.....	11-6
Standard and Optional Dynamo Information	11-6
Standard and Optional Alternator Information.....	11-6
Alternator Specifications.....	11-6
Dynamo Specifications.....	11-7
Alternator Troubleshooting	11-8
Alternator Components	11-9
Alternator Wiring Diagram	11-10
Alternator Standard Output	11-11
Alternator	11-12
Removal of Alternator.....	11-12
Disassembly of Alternator.....	11-12
Reassembly of Alternator	11-14
Installation of Alternator.....	11-16
Dynamo Component Location.....	11-17
Dynamo Wiring Diagram	11-18
Operation of Dynamo	11-18
Dynamo Standard Output	11-19
Testing of Dynamo	11-20
Testing Stator Coil Continuity.....	11-20
Testing Stator Coil Short-to-Ground.....	11-20
Testing Dynamo Regulated Output	11-20

ALTERNATOR

Dynamo.....	11-20
Removal of Dynamo.....	11-20
Disassembly of Dynamo.....	11-21
Reassembly of Dynamo	11-21
Installation of Dynamo.....	11-22

BEFORE YOU BEGIN SERVICING

⚠ WARNING



ENTANGLEMENT HAZARD!

- Stop the engine before you begin to service it.
- NEVER leave the key in the key switch when you are servicing the engine. Someone may accidentally start the engine and not realize you are servicing it. This could result in a serious injury.
- If you must service the engine while it is operating, remove all jewelry, tie back long hair, and keep your hands, other body parts and clothing away from moving / rotating parts.
- Failure to comply could result in death or serious injury.

0000010en

⚠ WARNING



SHOCK HAZARD!

- Turn off the battery switch (if equipped) or disconnect the negative battery cable before servicing the electrical system.
- Check the electrical harnesses for cracks, abrasions, and damaged or corroded connectors. ALWAYS keep the connectors and terminals clean.
- Failure to comply could result in death or serious injury.

0000009en

⚠ WARNING



BURN HAZARD!

- Keep your hands and other body parts away from hot engine surfaces such as the muffler, exhaust pipe, turbocharger (if equipped) and engine block during operation and shortly after you shut the engine down. These surfaces are extremely hot while the engine is operating and could seriously burn you.
- Failure to comply could result in death or serious injury.

0000015en

⚠ WARNING



FUME / BURN HAZARD!

- Always read and follow safety related precautions found on containers of hazardous substances like parts cleaners, primers, sealants and sealant removers.
- Failure to comply could result in death or serious injury.

0000014en

⚠ CAUTION



PINCH HAZARD!

Carefully rotate the alternator toward the cylinder block while loosening the V-belt. Failure to comply may result in minor or moderate injury.

0000014en

⚠ CAUTION



FLYING OBJECT HAZARD!

- ALWAYS wear eye protection when servicing the engine and when using compressed air or high-pressure water. Dust, flying debris, compressed air, pressurized water or steam may injure your eyes.
- Failure to comply may result in minor or moderate injury.

0000003en

CAUTION



NEVER permit anyone to operate the engine or driven machine without proper training.

- Read and understand this Operation Manual before you operate or service the machine to ensure that you follow safe operating practices and maintenance procedures.
- Machine safety signs and labels are additional reminders for safe operating and maintenance techniques.
- See your authorized Yanmar industrial engine dealer or distributor for additional training.

0000002en

CAUTION

Do not short-circuit the charging system between alternator terminals IG and L. Damage to the alternator will result.

0000035en

CAUTION

Do not connect a load between alternator terminals L and E. Damage to the alternator will result.

0000036en

CAUTION

Using a non-specified V-belt will cause inadequate charging and shorten the belt life. Use the specified belt.

0000052en

CAUTION

Do not operate the engine if the alternator is producing unusual sounds. Damage to the alternator will result.

0000039en

CAUTION

Agricultural or other chemicals, especially those with a high sulfur content, can adhere to the IC regulator. This will corrode the conductor and result in battery over-charging (boiling) and charging malfunctions. Consult Yanmar before using the equipment in such an environment or the warranty is voided.

0000053en

CAUTION

Do not remove the positive (+) battery cable from alternator terminal B while the engine is operating. Damage to the alternator will result.

0000037en

CAUTION

Do not use a high-pressure wash directly on the alternator. Water will damage the alternator and result in inadequate charging.

0000049en

CAUTION

Do not turn the battery switch OFF while the engine is operating. Damage to the alternator will result.

0000038en

CAUTION

Do not reverse the positive (+) and negative (-) ends of the battery cable. The alternator diode and stator coil will be damaged.

0000050en

CAUTION

When the battery indicator goes out, it should not come on again. The battery indicator only comes on during operation if the alternator fails. However, if an LED is used in the battery indicator, the LED will shine faintly during normal operation.

0000051en

INTRODUCTION

This section of the *Service Manual* describes the servicing of the dynamos and alternators. Yanmar Part No. 129423-77200 alternator is used in this section to show the service procedures for the representative alternator. Yanmar Part No. 171301-77201 dynamo is used in this section to show the service procedures for the representative dynamo. For specific part detail, see the *Parts Catalog* for the engine you are working on.

STANDARD AND OPTIONAL DYNAMO INFORMATION

YANMAR Part Number	Mfg.	Mfg. Part Number	Specification
171301-77201	Kokusan	GP8138	DC12V-15A
119910-77200	Kokusan	GP9191	DC12V-20A

STANDARD AND OPTIONAL ALTERNATOR INFORMATION

YANMAR Part Number	Mfg.	Mfg. Part Number	Specification
119620-77201	Denso	100211-4531	DC12V-40A
129423-77200	Denso	101211-1170	DC12V-40A with Pulse
129961-77200	Denso	101211-2591	DC12V-55A
119626-77210	Denso	101211-2951	DC12V-55A with Pulse

ALTERNATOR SPECIFICATIONS

Yanmar Part Number	129423-77200
Nominal Output (13.5 Volts Heat)	40 Amps
Weight	6.17 lb (2.8 kg)
Revolution Direction (As Viewed From Pulley)	Clockwise
Rating	Continuous
Battery Voltage	12 Volts
Rated Revolution	5000 rpm (min ⁻¹)
Operating Range	1350 - 18000 rpm (min ⁻¹)
Grounding Characteristics	Negative (-) Side of Circuit
Integrated Regulator	IC Regulator
Outside Diameter of Pulley	2.724 in. (69.2 mm)
Belt Shape	Type A

DYNAMO SPECIFICATIONS

Yanmar Part Number	119910-77200	
Nominal Output	20 Amps	
Weight	3.97 lb (1.8 kg)	
Revolution Direction (As Viewed From Pulley)	Clockwise	
Rating	Continuous	
Battery Voltage	12 Volts	
Rated Revolution	3500 rpm	
Operating Range	1400 - 6600 rpm	
Grounding Characteristics	Negative (-) Side of Circuit	
Regulator	Current Limiter (Part No. 119653-77710)	
Outside Diameter of Pulley	A-Belt	2.56 in. (65 mm)
	Special M-Belt	2.28 in. (58 mm)
Belt Shape	Type A or Type Special M	

ALTERNATOR TROUBLESHOOTING

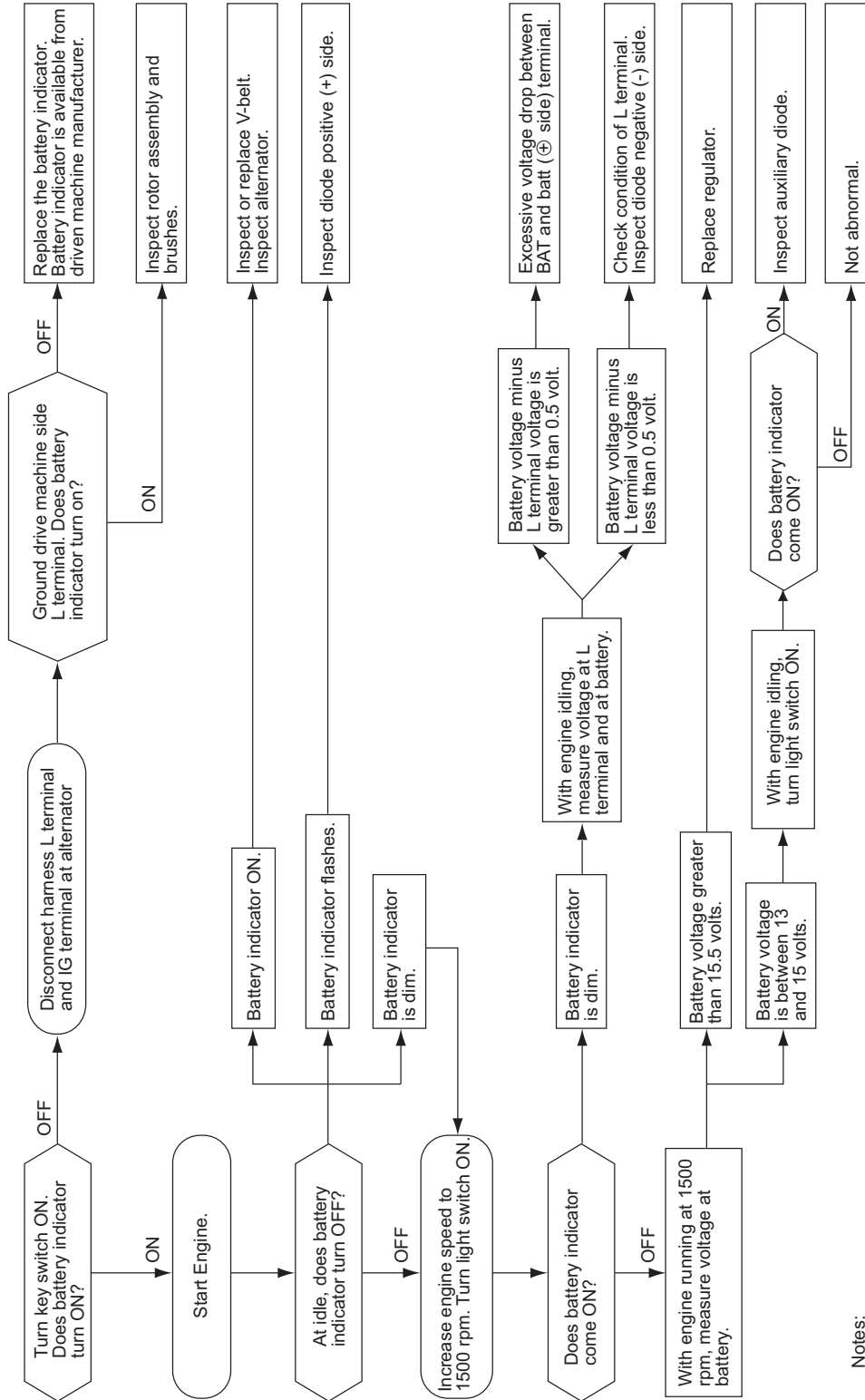

Notes:

- 1) Use a fully charged battery
- 2) DC voltmeter: 0 to 30 V, 0.5 class
- 3) The check method is also applicable to the bench test

ALTERNATOR COMPONENTS

Yanmar Part No. 129423-77200 alternator is used in this section to show the service procedures for the representative alternator. For specific part detail, see the *Parts Catalog* for the engine you are working on.

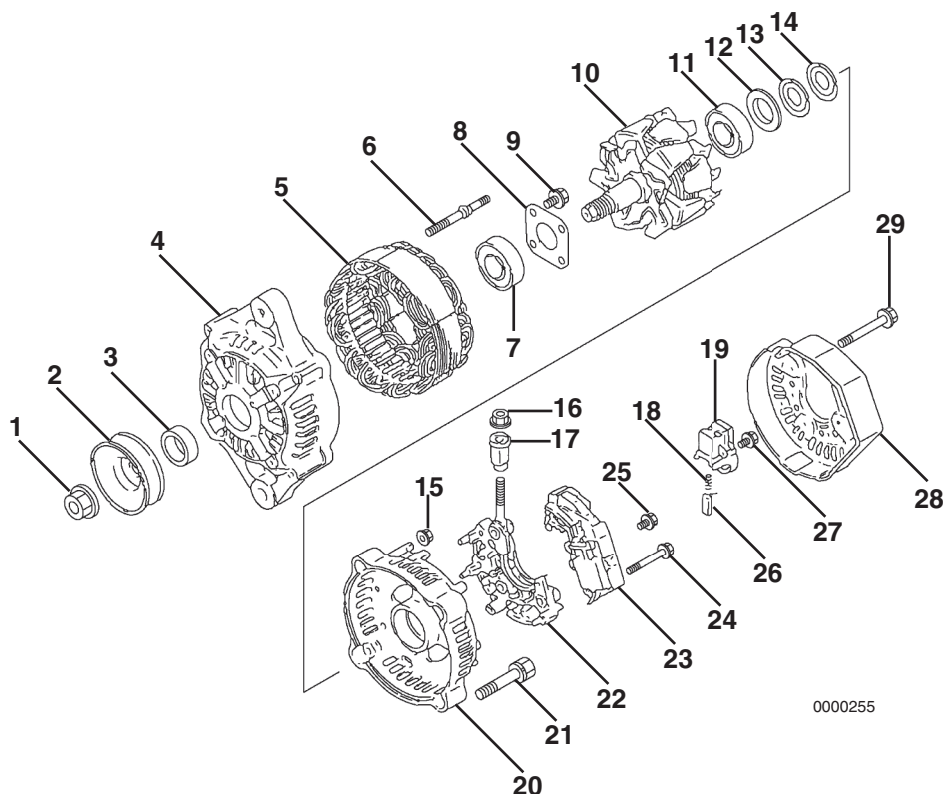
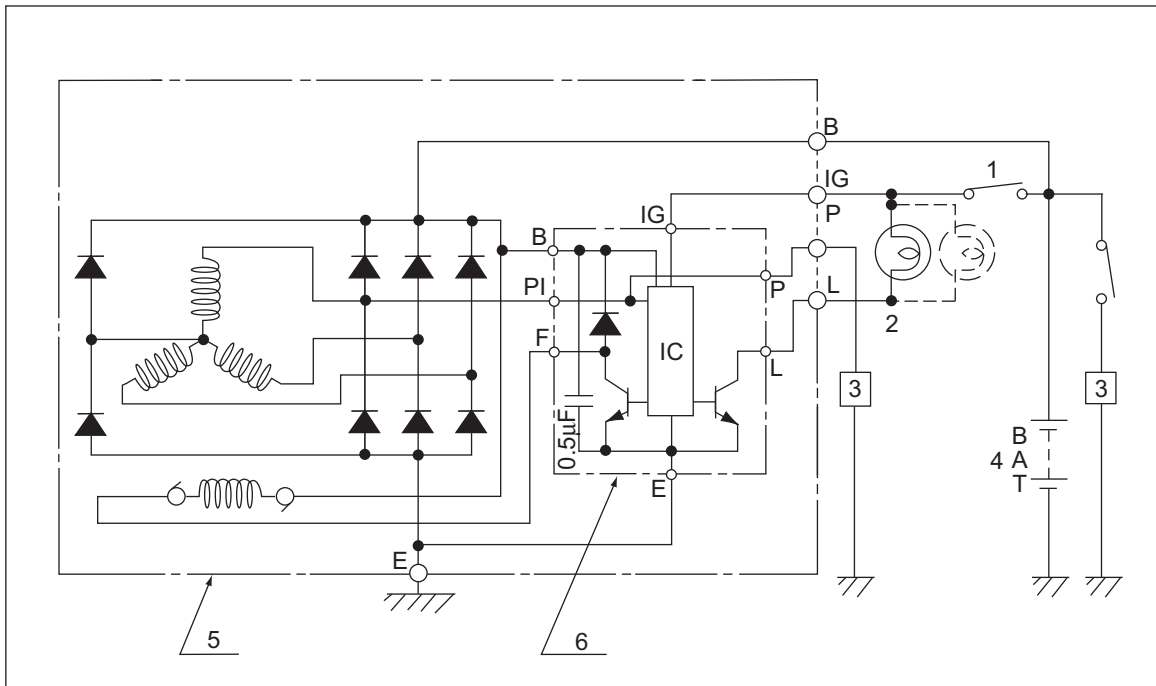

Figure 11-1

- | | |
|---------------------------------|----------------------------|
| 1 – Nut | 20 – Rear Frame Housing |
| 2 – Pulley | 21 – Bolt (2 used) |
| 3 – Collar | 22 – Holder |
| 4 – Front Frame Housing | 23 – IC Regulator Assembly |
| 5 – Stator Assembly | 24 – Bolt (2 used) |
| 6 – Stud (2 used) | 25 – Bolt |
| 7 – Front Frame Housing Bearing | 26 – Brush (2 used) |
| 8 – Bearing Cover | 27 – Bolt |
| 9 – Bearing Cover Bolt (4 used) | 28 – Rear Cover |
| 10 – Rotor Assembly | 29 – Bolt (3 used) |
| 11 – Rear Frame Housing Bearing | |
| 12 – Bearing Cover | |
| 13 – Thrust Washer | |
| 14 – Thrust Washer | |
| 15 – Nut (2 used) | |
| 16 – Nut | |
| 17 – Insulation Bushing | |
| 18 – Spring (2 used) | |
| 19 – Brush Holder | |

ALTERNATOR WIRING DIAGRAM



- 1 – Key Switch
- 2 – Charge Lamp (3.4 Watts Max.)
- 3 – Load
- 4 – Battery
- 5 – Alternator Assembly
- 6 – IC Regulator Assembly

Figure 11-2

CAUTION

Do not short-circuit the charging system between alternator terminals IG and L. Damage to the alternator will result.

0000035en

CAUTION

Do not remove the positive (+) battery cable from alternator terminal B while the engine is operating. Damage to the alternator will result.

0000037en

CAUTION

Do not connect a load between alternator terminals L and E. Damage to the alternator will result.

0000036en

ALTERNATOR STANDARD OUTPUT

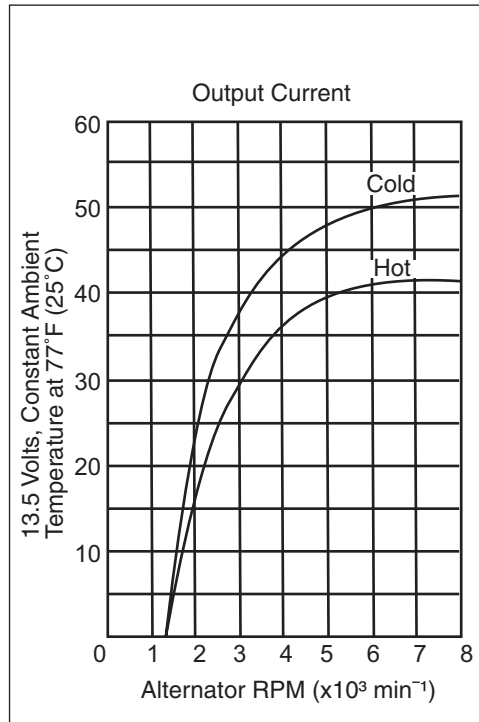

Figure 11-3

ALTERNATOR

⚠ WARNING**SHOCK HAZARD!**

- Turn off the battery switch (if equipped) or disconnect the negative battery cable before servicing the electrical system.
- Check the electrical harnesses for cracks, abrasions, and damaged or corroded connectors. ALWAYS keep the connectors and terminals clean.
- Failure to comply could result in death or serious injury.

000009en

Removal of Alternator

1. Disconnect the electrical wires from the alternator.
2. Loosen the V-belt.

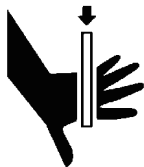
⚠ CAUTION**PINCH HAZARD!**

Carefully rotate the alternator toward the cylinder block while loosening the V-belt. Failure to comply may result in minor or moderate injury.

000014en

3. Remove the V-belt adjuster from the alternator bolt (**Figure 11-4, (1)**).
4. Remove the nut (**Figure 11-4, (2)**) from the gear case stud. Remove the alternator.

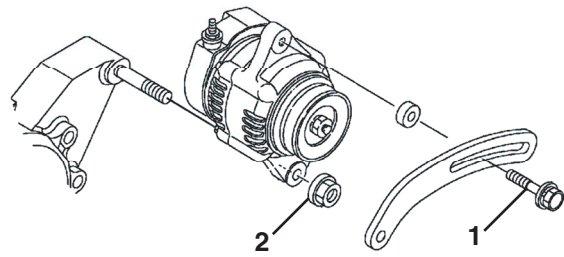

0000264

Figure 11-4**Disassembly of Alternator**

1. Remove the nut (**Figure 11-5, (1)**) from the shaft of the rotor assembly. Remove the pulley (**Figure 11-5, (2)**).

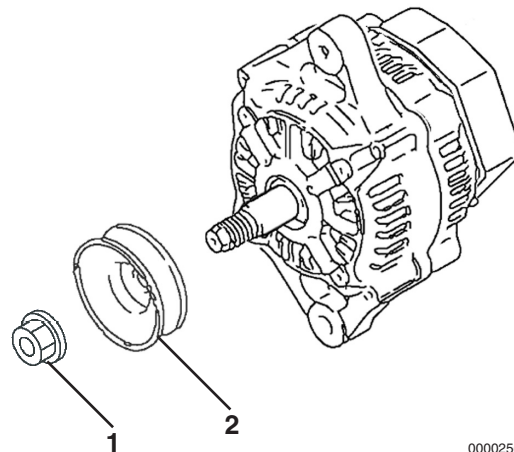

0000256

Figure 11-5

- Remove the three bolts (**Figure 11-6, (1)**) retaining the rear cover (**Figure 11-6, (2)**) to the rear frame assembly.

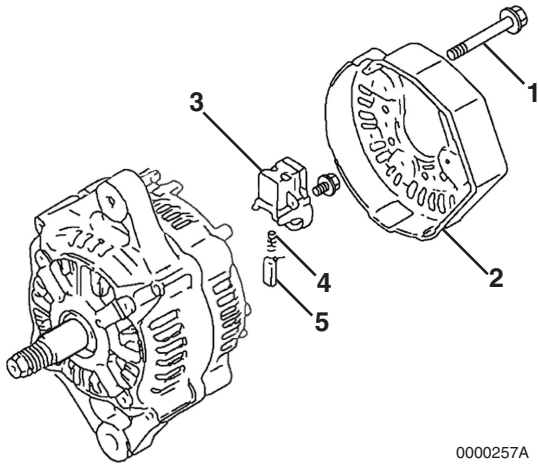

Figure 11-6

- Remove the brush holder (**Figure 11-6, (3)**). Remove the brush springs (**Figure 11-6, (4)**) and brushes (**Figure 11-6, (5)**).
- Remove the bolt retaining the regulator assembly (**Figure 11-7, (1)**) to the holder (**Figure 11-7, (2)**).

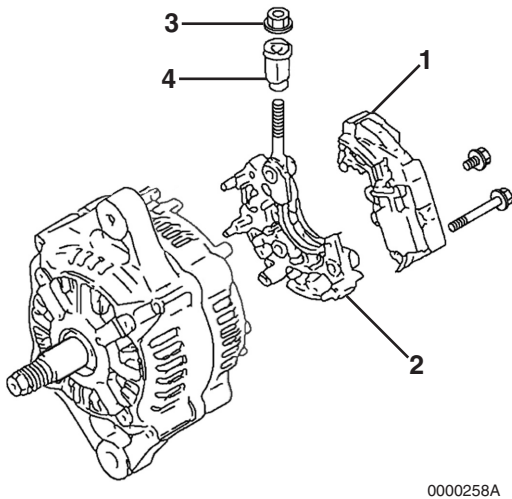

Figure 11-7

- Remove the bolts retaining the holder (**Figure 11-7, (2)**) to the rear frame housing. Remove the holder.
- Remove the nut (**Figure 11-7, (3)**) retaining the insulation bushing (**Figure 11-7, (4)**). Remove the insulation bushing.
- Remove the two bolts (**Figure 11-8, (1)**) and two nuts (**Figure 11-8, (2)**) securing the rear frame housing to the front frame housing.

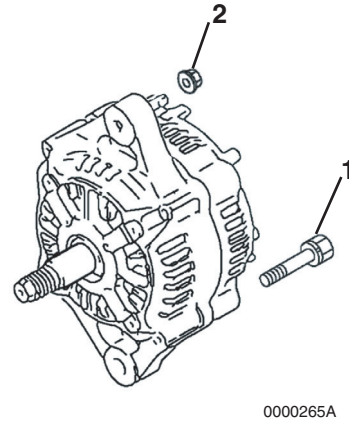

Figure 11-8

- Using a press, remove the rotor assembly (**Figure 11-9, (1)**) from the front frame housing (**Figure 11-9, (2)**) and rear frame housing (**Figure 11-10, (1)**).

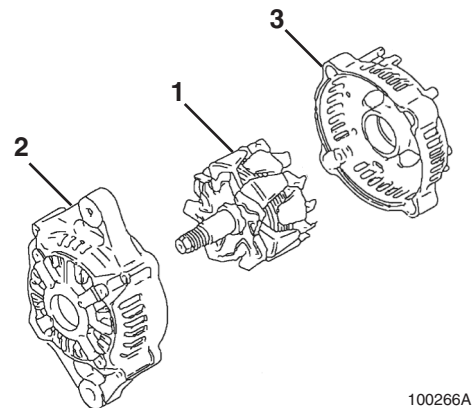

Figure 11-9

- Remove the stator assembly (Figure 11-10, (1)) from the front frame housing.

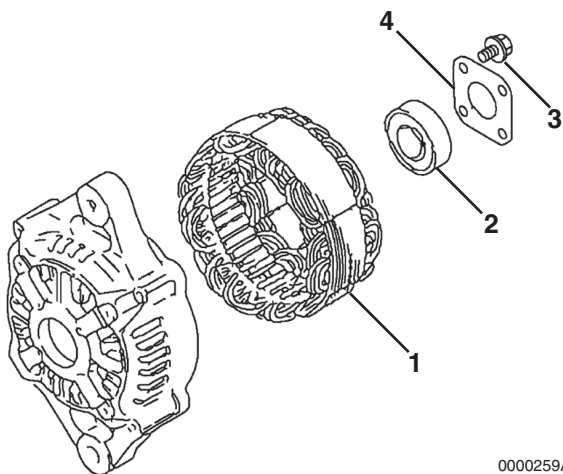

Figure 11-10

- If it is necessary to replace the bearing (Figure 11-10, (2)) in the front frame housing, remove the four bolts (Figure 11-10, (3)) securing the plate (Figure 11-10, (4)) to the front frame housing. Remove the plate. Use a puller to remove the bearing. Discard the bearing.
- If it is necessary to replace the bearing (Figure 11-11, (1)) in the rear frame housing, use a puller to remove. Discard the bearing. Remove the bearing cover (Figure 11-11, (2)) and two thrust washers (Figure 11-11, (3)).

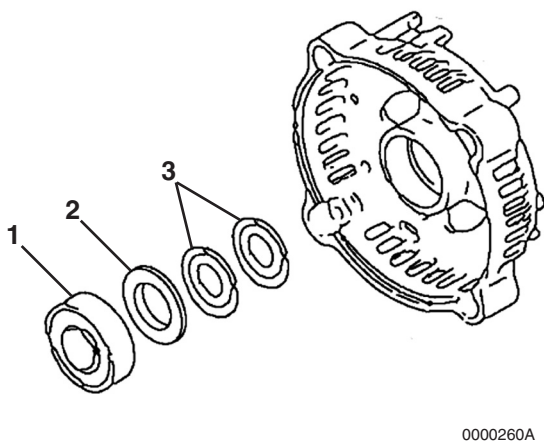

Figure 11-11

Reassembly of Alternator

- If removed, reinstall the two thrust washers (Figure 11-12, (3)) and bearing cover (Figure 11-12, (2)) in the rear frame housing. Lubricate the outside diameter of a new bearing (Figure 11-12, (1)). Press the bearing into the rear frame housing.

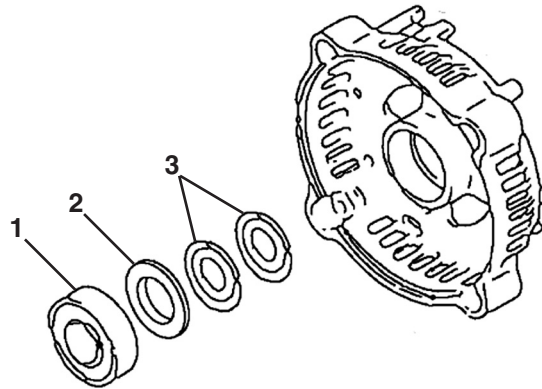

Figure 11-12

- If removed, lubricate the outside diameter of a new front frame housing bearing. Press the bearing (Figure 11-13, (2)) into the front frame housing. Reinstall the plate (Figure 11-13, (4)) to the front housing. Tighten the four bolts (Figure 11-13, (3)).

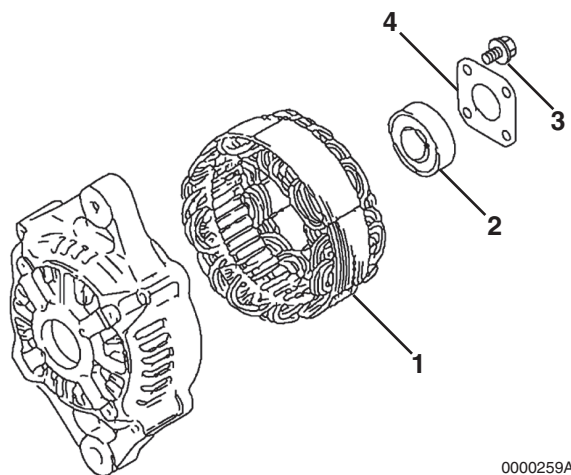

Figure 11-13

3. Position the stator assembly (**Figure 11-13, (1)**) on the front frame housing studs.
4. Lubricate the shaft of the rotor assembly (**Figure 11-14, (1)**). Press the rotor assembly into the front frame housing (**Figure 11-14, (2)**) and rear frame housing (**Figure 11-14, (3)**).

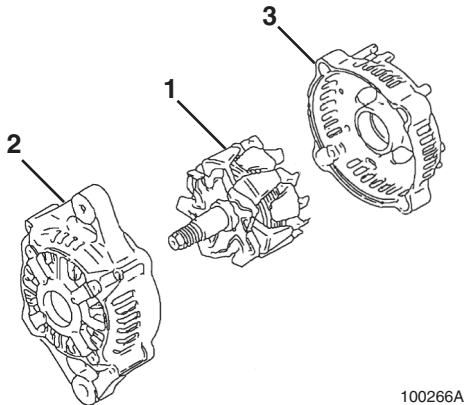

Figure 11-14

5. Align the front frame housing with the rear frame housing. Reinstall the two bolts (**Figure 11-15, (1)**) and two nuts (**Figure 11-15, (2)**).

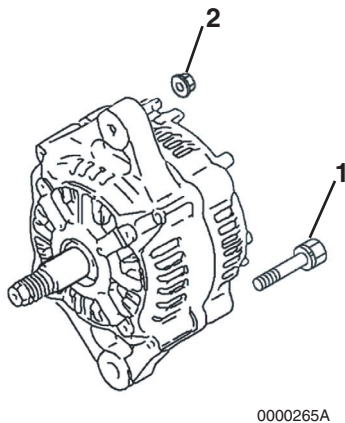

Figure 11-15

6. Reinstall the insulation bushing (**Figure 11-16, (4)**) and nut (**Figure 11-16, (3)**).

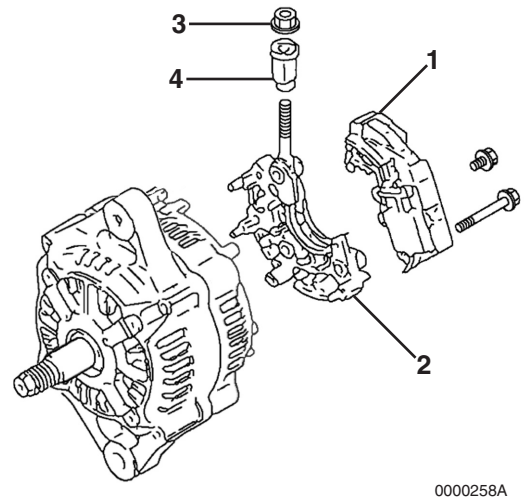

Figure 11-16

7. Reassemble the regulator assembly (**Figure 11-16, (1)**) to the holder (**Figure 11-16, (2)**).
8. Reinstall the brush holder (**Figure 11-17, (3)**), springs (**Figure 11-17, (4)**) and brushes (**Figure 11-17, (5)**).
9. Reattach the regulator assembly and holder to the rear frame housing.

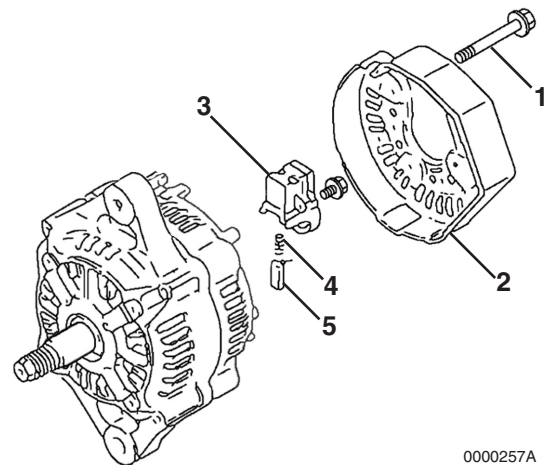

Figure 11-17

10. Reinstall the rear cover (**Figure 11-17, (2)**) to the rear frame housing with three bolts (**Figure 11-17, (1)**).

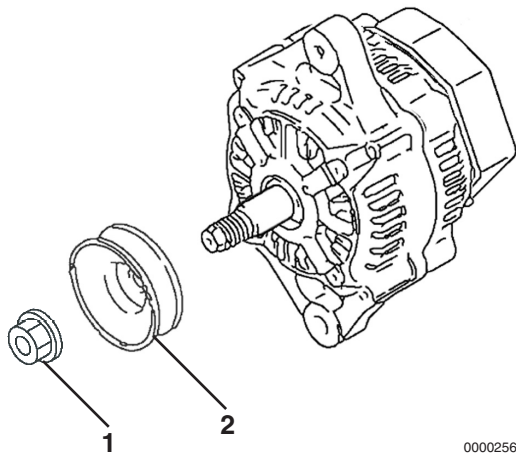

Figure 11-18

11. Reassemble the pulley (**Figure 11-18, (2)**) and nut (**Figure 11-18, (1)**) to the shaft of the rotor assembly. Tighten the nut.

Installation of Alternator

1. Position the alternator on the gear case. Loosely reinstall the nut (**Figure 11-19, (2)**) on the gear case stud and the V-belt adjuster bolt (**Figure 11-19, (1)**).

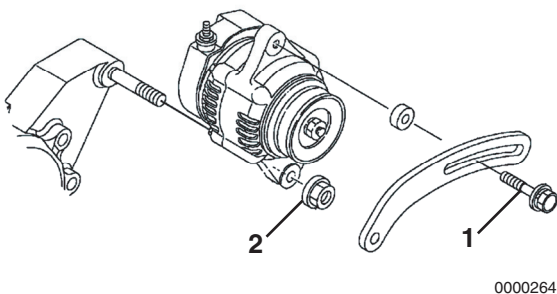

Figure 11-19

2. Reconnect the electrical wires to the alternator. Tighten the nuts to 15 - 20 in.-lb (1.7-2.3 N·m; 17-23 kgf·m).
3. Reinstall the V-belt. Tighten the V-belt to the proper tension. *See Check and Adjust Cooling Fan V-Belt on page 5-27.*

4. Start the engine. Listen for any unusual sounds from the alternator.

CAUTION

Do not operate the engine if the alternator is producing unusual sounds. Damage to the alternator will result.

0000039en

5. Verify that the charge indicator is ON while the engine is operating. If the charge indicator is not ON, repair the problem before operating the engine.

DYNAMO COMPONENT LOCATION

Yanmar Part No. 171301-77201 dynamo is used in this section to show the service procedures for the representative dynamo. For specific part detail, see the *Parts Catalog* for the engine you are working on.

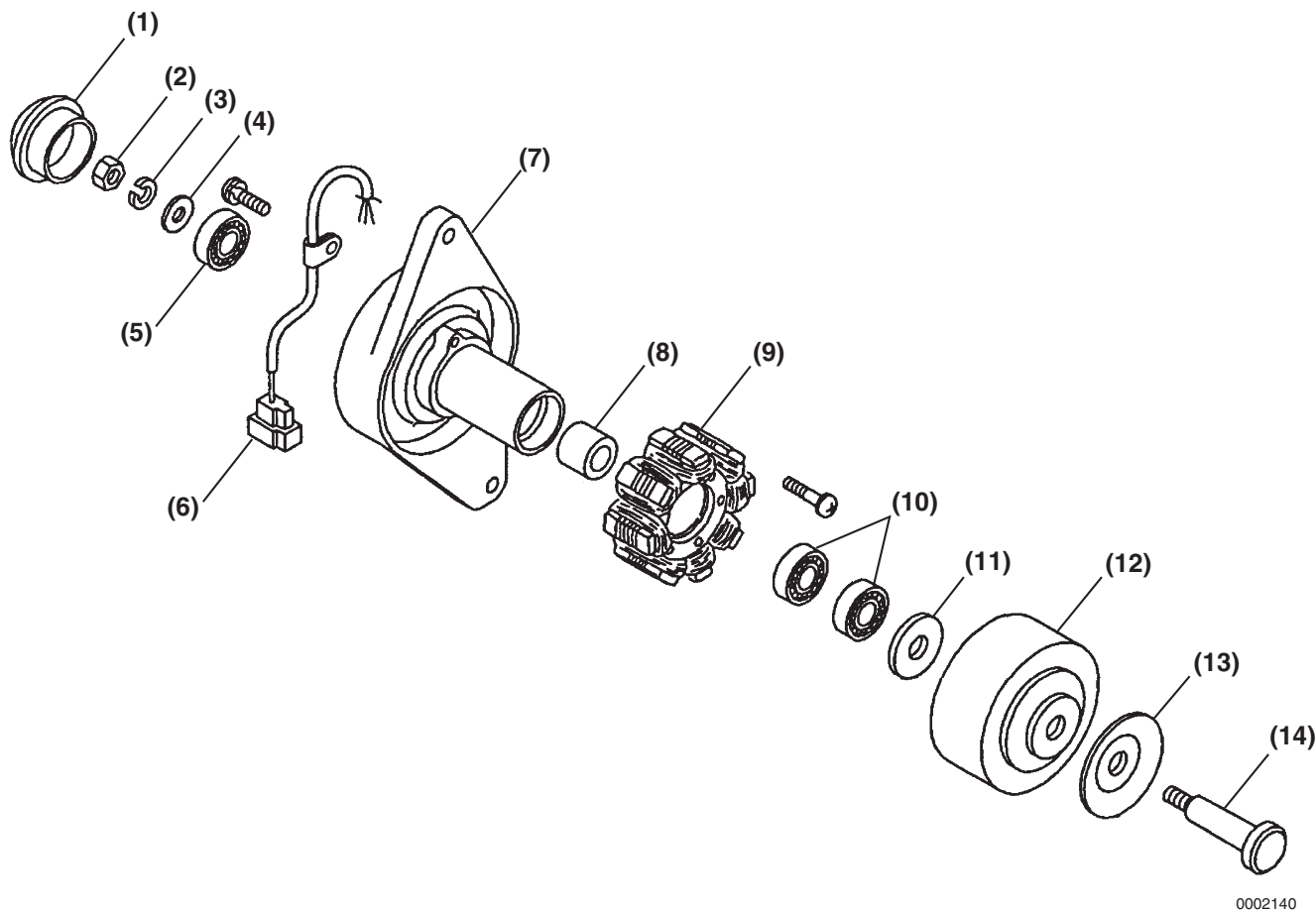

0002140

Figure 11-20

- 1 – Rear Cover
- 2 – Nut
- 3 – Lock Washer
- 4 – Flat Washer
- 5 – Rear Bearing
- 6 – Output Wire and Connector
- 7 – Plate

- 8 – Spacer
- 9 – Stator Assembly
- 10 – Front Bearing (2 used)
- 11 – Flat Washer
- 12 – Flywheel Assembly
- 13 – Pulley Half
- 14 – Through Bolt

DYNAMO WIRING DIAGRAM

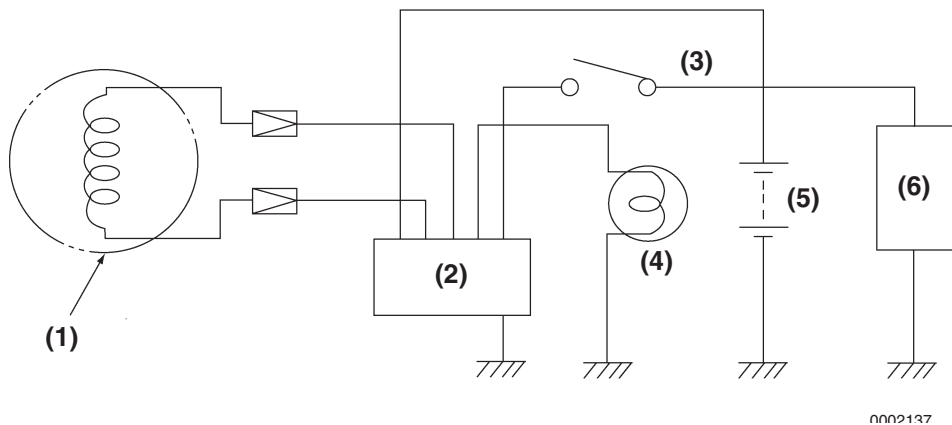

Figure 11-21

- 1 – Dynamo
- 2 – Current Limiter Assembly
- 3 – Key Switch

- 4 – Charge Lamp (3.4 Watts Max.)
- 5 – Battery
- 6 – Load

OPERATION OF DYNAMO

The dynamo consists of a series of permanent magnets that rotate around a stationary stator coil. The magnets are attached to the flywheel which is rotated via the engine cooling fan drive belt. The resultant output is an AC (alternating current) signal. The AC is converted to DC (direct current) by the current limiter. The current limiter outputs charging DC current to the battery.

DYNAMO STANDARD OUTPUT

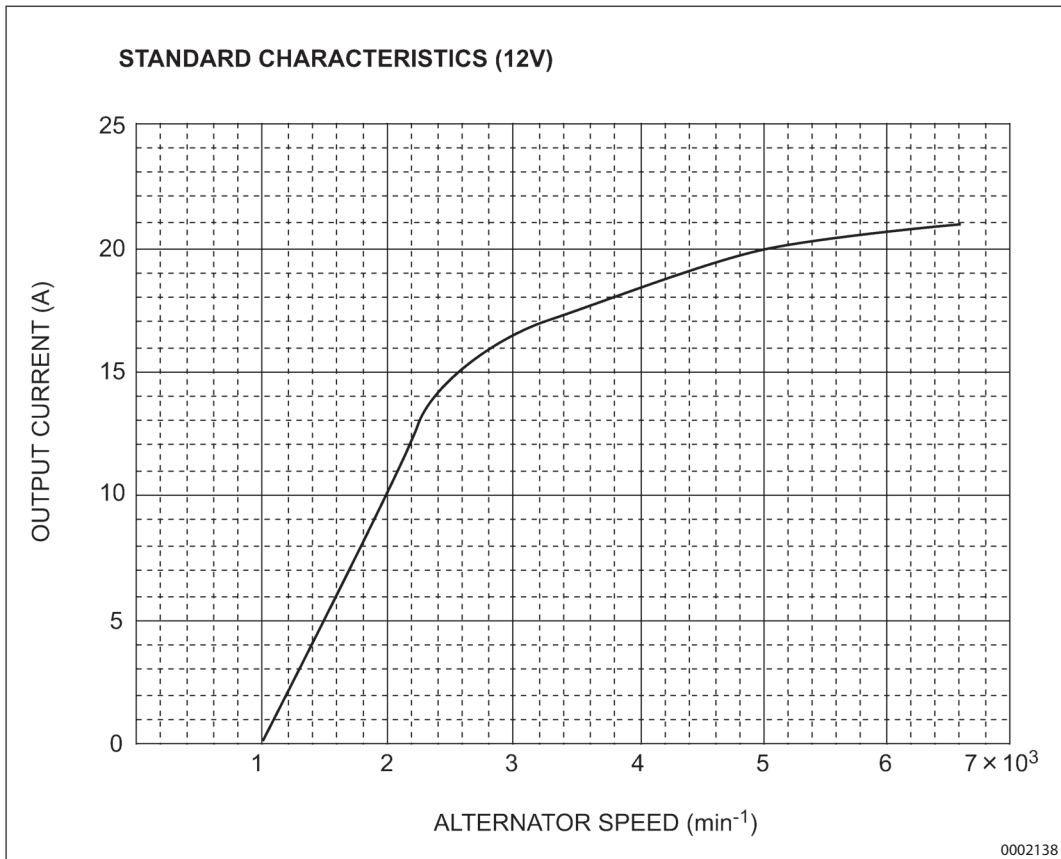

Figure 11-22

TESTING OF DYNAMO

Use a circuit tester or multimeter to perform the following tests.

Testing Stator Coil Continuity

1. Disconnect the dynamo output wire connector.
2. Connect one meter lead to each of the stator wire terminals and read the meter.

Results: The meter reading should indicate continuity. If continuity is not indicated, the windings are open and the stator must be replaced.

Testing Stator Coil Short-to-Ground

1. Disconnect the dynamo output wire connector.
2. Test continuity between each stator wire terminal and engine ground.

Results: The meter reading should indicate infinity. If the meter reading indicates continuity, the windings are shorted to ground and the stator must be replaced.

Testing Dynamo Regulated Output

1. Test and record the battery voltage with the engine OFF.
2. Start the engine and operate it at normal operating rpm.
3. Check the battery voltage with the engine running.

Results: The meter reading with the engine running must be higher than with the engine not running.

- If results are not correct, test the stator for continuity and shorts to the ground.
- Check the charging system wiring.
- If no problems are found in previous checks, replace the IC regulator.

DYNAMO

Removal of Dynamo

1. Disconnect the output wire connector from the dynamo.
2. Loosen the V-belt.



3. Remove the V-belt adjuster from the dynamo bolt (**Figure 11-23, (1)**).
4. Remove the nut (**Figure 11-23, (2)**) from the gear case stud. Remove the dynamo.

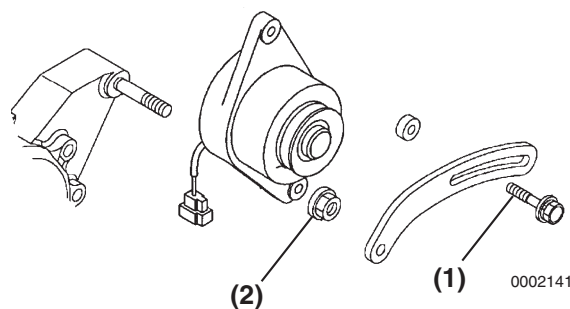

Figure 11-23

Disassembly of Dynamo

1. Remove the rear cover (**Figure 11-24, (1)**).
2. Remove the nut (**Figure 11-23, (2)**), lock washer (**Figure 11-24, (3)**), and flat washer (**Figure 11-24, (4)**).

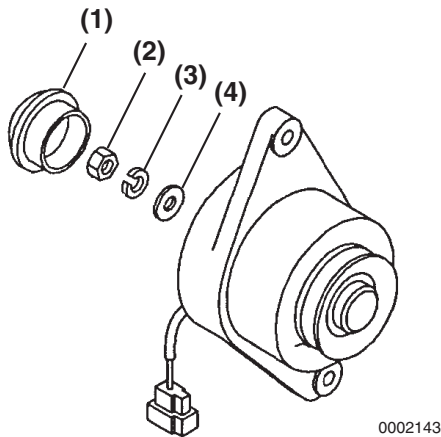

Figure 11-24

3. Remove the through bolt (**Figure 11-25, (1)**), pulley half (**Figure 11-25, (2)**), flywheel (**Figure 11-25, (3)**), flat washer (**Figure 11-25, (4)**), bearings (**Figure 11-25, (5)**), and spacer (**Figure 11-25, (6)**).

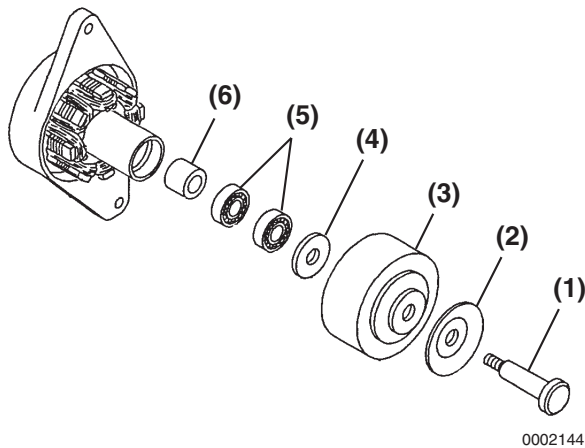

Figure 11-25

4. Remove the screws (**Figure 11-26, (1)**) and the stator assembly (**Figure 11-26, (2)**).
5. Remove the rear bearing (**Figure 11-26, (3)**).

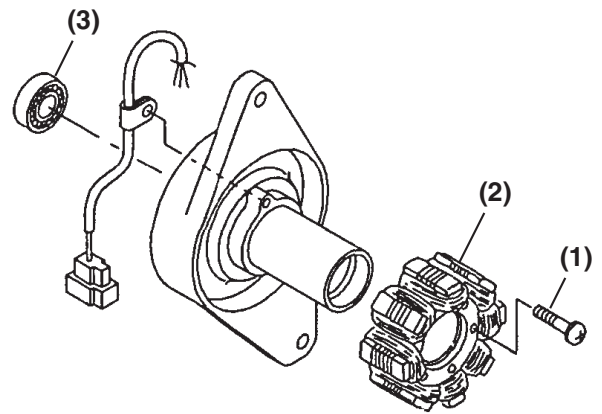

Figure 11-26

Reassembly of Dynamo

1. Reinstall the rear bearing (**Figure 11-26, (3)**).
2. Reinstall the stator (**Figure 11-26, (1)**).
3. Reinstall screws (**Figure 11-26, (1)**).
4. Reinstall the front bearings (**Figure 11-27, (5)**) and spacer (**Figure 11-27, (6)**).
5. Reinstall the flat washer (**Figure 11-27, (4)**), flywheel (**Figure 11-27, (3)**), pulley half (**Figure 11-27, (2)**), and through bolt (**Figure 11-27, (1)**).

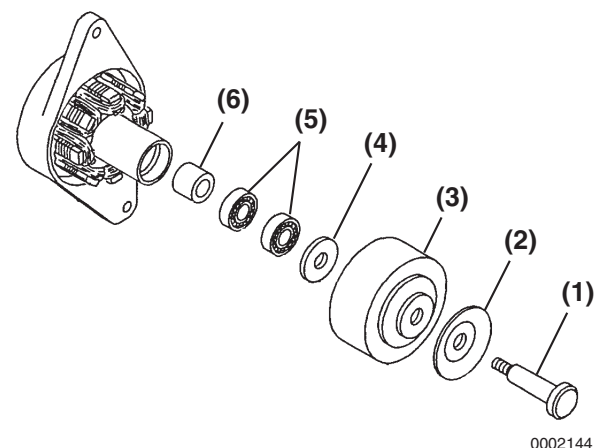

Figure 11-27

6. Reinstall the flat washer (**Figure 11-28, (4)**), lock washer (**Figure 11-28, (3)**), and nut (**Figure 11-28, (2)**). Tighten the nut to the specified torque.
7. Reinstall the rear cap (**Figure 11-28, (1)**).

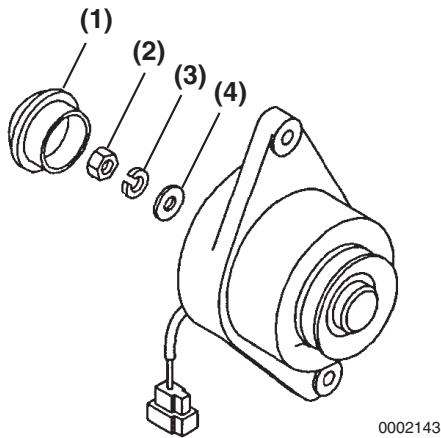

Figure 11-28

Installation of Dynamo

1. Position the dynamo on the gear case. Loosely reinstall the nut (**Figure 11-29, (2)**) on the gear case stud and the V-belt adjuster bolt (**Figure 11-29, (1)**).

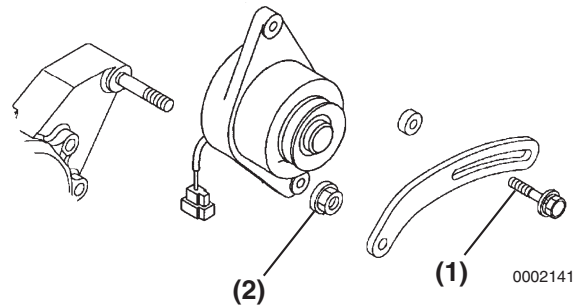

Figure 11-29

2. Reconnect the dynamo output wire connector.
3. Reinstall the V-belt. Tighten the V-belt to the proper tension. *See Check and Adjust Cooling Fan V-Belt on page 5-27.*
4. Start the engine. Listen for any unusual sounds from the alternator.

CAUTION

Do not operate the engine if the alternator is producing unusual sounds. Damage to the alternator will result.

0000039en

5. Verify that the charge indicator is ON while the engine is operating. If the charge indicator is not ON, repair the problem before operating the engine.

Section 12

ELECTRIC WIRING

	Page
Electric Wiring Precautions	12-3
Electric Wire Resistance	12-4
Battery Cable Resistance.....	12-5
Electrical Wire Sizes - Voltage Drop	12-6
Conversion of AWG to European Standards.....	12-7

This Page Intentionally Left Blank

ELECTRIC WIRING PRECAUTIONS

Failure to follow these precautions may result in the failure of an electrical component and the loss of warranty coverage on that item as well as related items. Make sure that all users read and understand these precautions.

CAUTION

Do not reverse the positive (+) and negative (-) ends of the battery cable. The alternator diode and stator coil will be damaged.

0000050en

CAUTION

When the battery indicator goes out, it should not come on again. The battery indicator only comes on during operation if the alternator fails. However, if an LED is used in the battery indicator, the LED will shine faintly during normal operation.

0000051en

CAUTION

Make sure that the combined total resistance of the battery cable in both directions between the starter motor and the battery is within the value indicated in the *Battery Cable Resistance chart* in the *Electric Wiring Section* of this manual. The starter motor will malfunction and fail if the resistance is higher than the specified value.

0000057en

CAUTION

Removing the battery cables or the battery while the engine is operating may cause damage to the current limiter depending on the electrical equipment being used. This situation could cause loss of control of output voltage. The continuous high voltage of 23-24 volts (for 5000 rpm dynamo) will damage the current limiter and other electrical equipment.

0000058en

CAUTION

Reversing the battery cable connections at the battery or on the engine will destroy the SCR diode in the current limiter. This will cause the charging system to malfunction and may cause damage to the electrical harnesses.

0000059en

ELECTRIC WIRE RESISTANCE

AWG	Metric Nominal mm ²	Ohms / Foot
20	0.5	0.009967
18	0.8	0.006340
16	1.25	0.004359
14	2	0.002685
12	3	0.001704
10	5	0.001073
8	8	0.000707
6	15	0.000421
4	20	0.000270
2	30	0.000158
1	40	0.000130
0 (1/0)	50	0.000103
00 (2/0)	60	0.000087
000 (3/0)	85	0.000066
0000 (4/0)	100	0.000051

Wiring voltage drop should not exceed 5% $[0.05] \times 12 \text{ Volts} = 0.6 \text{ Volts}$.

Voltage Drop = Current [Amps] x Length of Wire [Feet] x Resistance per Foot [Ohms]

Example:

Current draw of 100 Amps x 3 feet of 4 AWG wire

$100 \text{ Amps} \times 3 \text{ Feet} \times 0.000270 = 0.08 \text{ Volts [Voltage Drop]}$

BATTERY CABLE RESISTANCE

AWG	mm ²	Maximum Total Battery Cable Length (Positive Cable + Negative Cable + a*) 12V Starter Motor Output			
		Less Than 2.68 hp (2 kW)		Greater Than 2.68 hp (2 kW)	
		m	ft	m	ft
6	15	1.5	4.75	N/A	N/A
4	20	2.3	7.4	N/A	N/A
2	30	3.8	12.6	2.3	7.5
1	40	4.6	15.3	2.8	9.2
0 (1/0)	50	5.9	19.5	3.5	11.6
00 (2/0)	60	7.0	22.8	4.2	13.7
000(3/0)	85	9.3	30.5	5.6	18.3
0000 (4/0)	100	11.9	39.0	7.1	23.4
00000 (5/0)	125	N/A	N/A	8.3	27.3
000000 (6/0)	150	N/A	N/A	10.1	33.3

Note: Total allowable resistance of the complete battery cable circuit (positive cable + negative cable + a*)
(a*: Resistance (⊙) of a battery switch or other electrical equipment having high resistance)

Note: For starter motors of less than 2.68 HP (2 kW): the total resistance must be less than 0.002 Ω. For starter motors of greater than 2.68 HP (2 kW): the total resistance must be less than 0.0012 Ω.

ELECTRICAL WIRE SIZES - VOLTAGE DROP

Total current on circuit in amps.	Length of conductor from source of current to device and back to source (in feet)																		
	10	15	20	25	30	40	50	60	70	80	90	100	110	120	130	140	150	160	170
12 Volts	Wire Size (AWG)																		
5	18	16	14	12	12	10	10	10	8	8	8	6	6	6	6	6	6	6	6
10	14	12	10	10	10	8	6	6	6	6	4	4	4	4	2	2	2	2	2
15	12	10	10	8	8	6	6	6	4	4	2	2	2	2	2	1	1	1	1
20	10	10	8	6	6	6	4	4	2	2	2	2	1	1	1	0	0	0	2/0
25	10	8	6	6	6	4	4	2	2	2	1	1	0	0	0	2/0	2/0	2/0	3/0
30	10	8	6	6	4	4	2	2	1	1	0	0	0	2/0	2/0	3/0	3/0	3/0	3/0
40	8	6	6	4	4	2	2	1	0	0	2/0	2/0	3/0	3/0	3/0	4/0	4/0	4/0	4/0
50	6	6	4	4	2	2	1	0	2/0	2/0	3/0	3/0	4/0	4/0	4/0				
60	6	4	4	2	2	1	0	2/0	3/0	3/0	4/0	4/0	4/0						
70	6	4	2	2	1	0	2/0	3/0	3/0	4/0	4/0								
80	6	4	2	2	1	0	3/0	3/0	4/0	4/0									
90	4	2	2	1	0	2/0	3/0	4/0	4/0										
100	4	2	2	1	0	2/0	3/0	4/0											
24 Volts																			
5	18	18	18	16	16	14	12	12	12	10	10	10	10	10	8	8	8	8	8
10	18	16	14	12	12	10	10	10	8	8	8	6	6	6	6	6	6	6	6
15	16	14	12	12	10	10	8	8	6	6	6	6	6	4	4	4	4	4	2
20	14	12	10	10	10	8	6	6	6	6	4	4	4	4	2	2	2	2	2
25	12	12	10	10	8	6	6	6	4	4	4	4	2	2	2	2	2	2	1
30	12	10	10	8	8	6	6	4	4	4	2	2	2	2	2	1	1	1	1
40	10	10	8	6	6	6	4	4	2	2	2	2	1	1	1	0	0	0	2/0
50	10	8	6	6	6	4	4	2	2	2	1	1	0	0	0	2/0	2/0	2/0	3/0
60	10	8	6	6	4	4	2	2	1	1	0	0	0	2/0	2/0	3/0	3/0	3/0	3/0
70	8	6	6	4	4	2	2	1	1	0	0	2/0	2/0	3/0	3/0	3/0	3/0	4/0	4/0
80	8	6	6	4	4	2	2	1	0	0	2/0	2/0	3/0	3/0	3/0	4/0	4/0	4/0	4/0
90	8	6	4	4	2	2	1	0	0	2/0	2/0	3/0	3/0	4/0	4/0	4/0	4/0	4/0	
100	6	6	4	4	2	2	1	0	2/0	2/0	3/0	3/0	4/0	4/0	4/0				

CONVERSION OF AWG TO EUROPEAN STANDARDS

Conductor Size (AWG)	Conductor Diameter (mm)	Conductor Cross-sectional Area (mm ²)
25	0.455	0.163
24	0.511	0.205
23	0.573	0.259
22	0.644	0.325
21	0.723	0.412
20	0.812	0.519
19	0.992	0.653
18	1.024	0.823
17	1.15	1.04
16	1.29	1.31
15	1.45	1.65
14	1.63	2.08
13	1.83	2.63
12	2.05	3.31
11	2.30	4.15
10	2.59	5.27
9	2.91	6.62
8	3.26	8.35
7	3.67	10.6
6	4.11	13.3
5	4.62	16.8
4	5.19	21.2
3	5.83	26.7
2	6.54	33.6
1	7.35	42.4
0 (1/0)	8.25	53.4
00 (2/0)	9.27	67.5
000(3/0)	10.40	85.0
0000 (4/0)	11.68	107.2
00000 (5/0)	13.12	135.1
000000 (6/0)	14.73	170.3
1.1 circular mil (CM) \cong 0.0005067 mm ²		

This Page Intentionally Left Blank

Section 13

TROUBLESHOOTING

	Page
Special Service Tools	13-3
Troubleshooting By Measuring Compression Pressure	13-4
Compression Pressure Measurement Method	13-4
Standard Compression Pressure	13-5
Engine Speed and Compression Pressure (Use for Reference)	13-5
Measured Value and Troubleshooting	13-6
Quick Reference Table For Troubleshooting	13-6
Troubleshooting Charts	13-7
Electric Wiring	13-19

This Page Intentionally Left Blank

SPECIAL SERVICE TOOLS

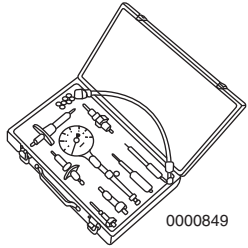
<p>Compression Gauge Kit</p>	<p>For measuring compression pressure Yanmar Part No. TOL-97190080</p>	 <p>0000849</p>
------------------------------	--	--

TROUBLESHOOTING BY MEASURING COMPRESSION PRESSURE

Compression pressure drop is one of major causes of increasing blow-by gas (engine oil contamination or increased engine oil consumption as a resultant phenomenon) or starting failure. The compression pressure is affected by the following factors:

1. Degree of clearance between piston and cylinder
2. Degree of clearance at intake / exhaust valve seat
3. Gas leak from nozzle gasket or cylinder head gasket

The pressure will drop due to increased parts wear. Pressure drop reduces the durability of the engine.

A pressure drop may also be caused by scratched cylinder or piston by dust entrance from the dirty air cleaner element or worn or broken piston ring. Measure the compression pressure to determine the condition of the engine.

Compression Pressure Measurement Method

1. Warm up the engine.
2. Stop the engine. Remove the high-pressure fuel injection lines as an assembly from the engine. *See Removal of High-Pressure Fuel Injection Lines on page 7-11.* Remove the fuel injector from the cylinder to be measured. *See Removal of Fuel Injectors on page 7-23.*

CAUTION

Remove or install the high-pressure fuel injection lines as an assembly whenever possible. Disassembling the high-pressure fuel injection lines from the retainers or bending any of the fuel lines will make it difficult to reinstall the fuel lines.

0000047en

3. Turn off the fuel supply valve in the fuel supply line. Disconnect the fuel injection stop solenoid at the connector. Crank the engine for a few seconds with the stop solenoid disconnected (no injection state) before installing the compression gauge adapter (**Figure 13-1, (1)**), this will expel any residual fuel from the cylinder.
4. Install one injector gasket at the tip end of the compression gauge adapter. Install the compression gauge and the compression gauge adapter at the cylinder to be measured.
5. Crank the engine until the compression gauge reading is stabilized.

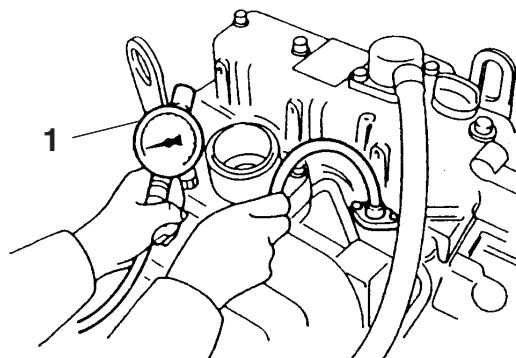

Figure 13-1

6. After performing the compression check, remove the compression gauge and compression gauge adapter from the cylinder. Reinstall the fuel injector, high-pressure fuel injection lines and reconnect the stop solenoid. *See Installation of the Fuel Injectors on page 7-29 and Installation of High-Pressure Fuel Injection Lines on page 7-12.*
7. Turn on the fuel supply valve and reconnect the injection pump stop solenoid.
8. Prime the fuel system. Check for leaks. Test the engine.

Standard Compression Pressure

Engine compression pressure list (reference value)

Engine Model	Compression Pressure at 250 rpm (250 min ⁻¹)		Deviation Between Cylinders
	Standard	Limit	
2TNV70 3TNV70	470 ± 15 psi (3.24 ± 0.1 MPa; 33 ± 1 kgf/cm ²)	370 ± 15 psi (2.55 ± 0.1 MPa; 26 ± 1 kgf/cm ²)	29 to 43 psi (0.2 to 0.3 MPa; 2 to 3 kgf/cm ²)
3TNV76	498 ± 15 psi (3.43 ± 0.1 MPa; 35 ± 1 kgf/cm ²)	399 ± 15 psi (2.75 ± 0.1 MPa; 28 ± 1 kgf/cm ²)	

Engine Speed and Compression Pressure (Use for Reference)

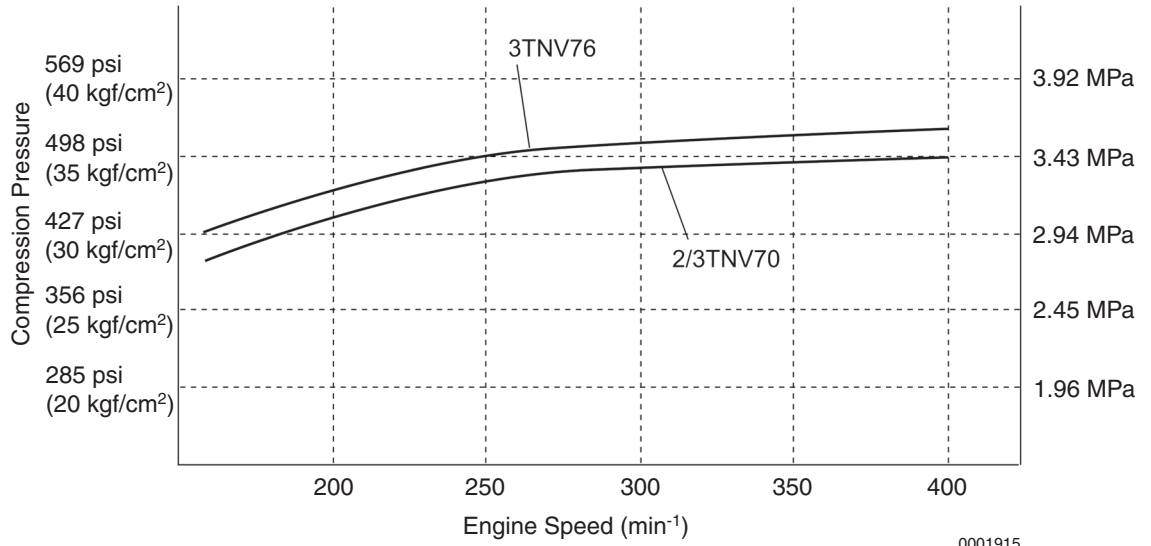

Figure 13-2

Measured Value and Troubleshooting

When the measured compression pressure is below the limit value, inspect each part by referring to the table below.

No.	Item	Cause	Corrective Action
1	Air Cleaner Element	Clogged element	Clean the element.
		Broken element	Replace the element.
		Defect at element seal portion	
2	Valve Clearance	Excessive or no clearance	Adjust the valve clearance.
3	Valve Timing	Incorrect valve clearance	Adjust the valve clearance.
4	Cylinder Head Gasket	Gas leak from gasket	Replace the gasket.
			Retighten the cylinder head bolts to the specified torque.
5	Intake / Exhaust Valve	Sticking valve	Replace the intake / exhaust valve.
	Valve Seat	Gas leak due to worn valve seat or foreign matter trapped in valve	Lap the valve seat.
6	Piston	Gas leak due to scratching or wear	Perform honing and use an oversized part.
	Piston Ring		
	Cylinder		

QUICK REFERENCE TABLE FOR TROUBLESHOOTING

The following table summarizes the general trouble symptoms and their causes. If any trouble symptom occurs, take corrective action before it becomes a serious problem so as not to shorten the engine service life.

Troubleshooting Charts

Trouble Symptom	Starting Problem		Insufficient Engine Output		Poor Exhaust Color		High Knocking Sound During Combustion		Abnormal Engine Sound		Uneven Combustion Sound		Engine Surging		Excessive Fuel Consumption		Engine Oil				Engine Coolant		Air Intake		Corrective Action	Reference Page	
	Engine Does Not Start	Engine Starts But Stops Soon.	Exhaust Color	Exhaust Color	During Work	Black	White	Black	High Knocking Sound	Abnormal Engine Sound	During Idling	During Work Operation	Excessive Engine Vibration	Difficulty in Returning to Low Speed	Excessive Fuel Consumption	Excessive Oil Consumption	Dilution by Diesel Fuel	Oil with Water	Low Oil Pressure	Excessive Blow-by Gas	Overheat	Low Water Temperature	Pressure Drop	Pressure Rise			Exhaust Temperature Rise
Cause	Improper Intake/Exhaust Valve Clearance	None	None	Ordinary	White	Black	Black	Black																		See "Measuring and Adjusting Valve Clearance" on page 6-34.	
	Compression Leakage from Valve Seat	Little	Little	Ordinary	White	Black	Black	Black																		See "Valve Face and Valve Seat" on page 6-28.	
	Intake/Exhaust Valve Seizure	None	None	Ordinary	White	Black	Black	Black																		See "Inspection of Intake and Exhaust Valves" on page 6-27.	
	Cylinder Head Gasket Blowout			Ordinary	White	Black	Black	Black																		See "Disassembly of Cylinder Head" on page 6-21.	
	Seized or Broken Piston Ring			Ordinary	White	Black	Black	Black																		See "Reassembly of Cylinder Head" on page 6-31.	
	Worn Piston Ring, Piston or Cylinder			Ordinary	White	Black	Black	Black																		See "Honing and Boring" on page 6-53.	
	Seized Crankpin Metal or Bearing			Ordinary	White	Black	Black	Black																		See "Inspection of Crankshaft and Camshaft Components" on page 6-46.	
	Improper Arrangement of Piston Ring Gaps			Ordinary	White	Black	Black	Black																		See "Reassembly of Pistons" on page 6-55.	

This Page Intentionally Left Blank

This Page Intentionally Left Blank

This Page Intentionally Left Blank

This Page Intentionally Left Blank

Trouble Symptom	Starting Problem		Insufficient Engine Output	Poor Exhaust Color		High Knocking Sound During Combustion	Abnormal Engine Sound	Uneven Combustion Sound	Engine Surging		Excessive Engine Vibration	Difficulty in Returning to Low Speed	Excessive Fuel Consumption	Engine Oil				Excessive Blow-by Gas	Engine Coolant		Air Intake		Exhaust Temperature Rise	Corrective Action	Reference Pages	
	Engine Does Not Start.	Engine Starts but Stops Soon.		Exhaust Color	Exhaust Color				During Work	During Work				None	Little	Much	Ordinary		White	Black	Excessive Oil Consumption	Dilution by Diesel Fuel				Oil with Water
Fuel System	Air in Fuel System	<input type="radio"/>	<input type="radio"/>	<input type="radio"/>	<input type="radio"/>	<input type="radio"/>	<input type="radio"/>	<input type="radio"/>	<input type="radio"/>	<input type="radio"/>	<input type="radio"/>	<input type="radio"/>	<input type="radio"/>	<input type="radio"/>	<input type="radio"/>	<input type="radio"/>	<input type="radio"/>	<input type="radio"/>	<input type="radio"/>	<input type="radio"/>	<input type="radio"/>	<input type="radio"/>	<input type="radio"/>	Bleed the Air.	See "Priming the Fuel System" on page 4-12.	
	Clogged or Cracked Fuel Line	<input type="radio"/>	<input type="radio"/>	<input type="radio"/>	<input type="radio"/>	<input type="radio"/>	<input type="radio"/>	<input type="radio"/>	<input type="radio"/>	<input type="radio"/>	<input type="radio"/>	<input type="radio"/>	<input type="radio"/>	<input type="radio"/>	<input type="radio"/>	<input type="radio"/>	<input type="radio"/>	<input type="radio"/>	<input type="radio"/>	<input type="radio"/>	<input type="radio"/>	<input type="radio"/>	<input type="radio"/>	Clean or Replace.	See "Check and Replace Fuel Hoses and Engine Coolant Hoses" on page 5-37.	
	Insufficient Fuel Supply to Fuel Injection Pump	<input type="radio"/>	<input type="radio"/>	<input type="radio"/>	<input type="radio"/>	<input type="radio"/>	<input type="radio"/>	<input type="radio"/>	<input type="radio"/>	<input type="radio"/>	<input type="radio"/>	<input type="radio"/>	<input type="radio"/>	<input type="radio"/>	<input type="radio"/>	<input type="radio"/>	<input type="radio"/>	<input type="radio"/>	<input type="radio"/>	<input type="radio"/>	<input type="radio"/>	<input type="radio"/>	<input type="radio"/>	<input type="radio"/>	Check the Fuel Tank Cock, Fuel Filter, Fuel Line, and Fuel Feed Pump.	See the appropriate procedure in Periodic Maintenance on page 5-1
	Uneven Injection Volume from Fuel Injection Pump	<input type="radio"/>	<input type="radio"/>	<input type="radio"/>	<input type="radio"/>	<input type="radio"/>	<input type="radio"/>	<input type="radio"/>	<input type="radio"/>	<input type="radio"/>	<input type="radio"/>	<input type="radio"/>	<input type="radio"/>	<input type="radio"/>	<input type="radio"/>	<input type="radio"/>	<input type="radio"/>	<input type="radio"/>	<input type="radio"/>	<input type="radio"/>	<input type="radio"/>	<input type="radio"/>	<input type="radio"/>	<input type="radio"/>	Check and Adjust.	See "Testing of Fuel Injectors" on page 7-24.
	Excessive Fuel Injection Volume	<input type="radio"/>	<input type="radio"/>	<input type="radio"/>	<input type="radio"/>	<input type="radio"/>	<input type="radio"/>	<input type="radio"/>	<input type="radio"/>	<input type="radio"/>	<input type="radio"/>	<input type="radio"/>	<input type="radio"/>	<input type="radio"/>	<input type="radio"/>	<input type="radio"/>	<input type="radio"/>	<input type="radio"/>	<input type="radio"/>	<input type="radio"/>	<input type="radio"/>	<input type="radio"/>	<input type="radio"/>	<input type="radio"/>	Check and Adjust.	See "Testing of Fuel Injectors" on page 7-24.
	Poor Spray Pattern from Fuel Injection Nozzle	<input type="radio"/>	<input type="radio"/>	<input type="radio"/>	<input type="radio"/>	<input type="radio"/>	<input type="radio"/>	<input type="radio"/>	<input type="radio"/>	<input type="radio"/>	<input type="radio"/>	<input type="radio"/>	<input type="radio"/>	<input type="radio"/>	<input type="radio"/>	<input type="radio"/>	<input type="radio"/>	<input type="radio"/>	<input type="radio"/>	<input type="radio"/>	<input type="radio"/>	<input type="radio"/>	<input type="radio"/>	<input type="radio"/>	Check and Adjust.	See "Testing of Fuel Injectors" on page 7-24.
	Priming Failure	<input type="radio"/>	<input type="radio"/>	<input type="radio"/>	<input type="radio"/>	<input type="radio"/>	<input type="radio"/>	<input type="radio"/>	<input type="radio"/>	<input type="radio"/>	<input type="radio"/>	<input type="radio"/>	<input type="radio"/>	<input type="radio"/>	<input type="radio"/>	<input type="radio"/>	<input type="radio"/>	<input type="radio"/>	<input type="radio"/>	<input type="radio"/>	<input type="radio"/>	<input type="radio"/>	<input type="radio"/>	<input type="radio"/>	Foreign Matter Trapped in the Valve Inside the Priming Pump (Disassemble and Clean).	See "Fuel System Components" on page 7-10.
	Clogged Strainer at Feed Pump Inlet	<input type="radio"/>	<input type="radio"/>	<input type="radio"/>	<input type="radio"/>	<input type="radio"/>	<input type="radio"/>	<input type="radio"/>	<input type="radio"/>	<input type="radio"/>	<input type="radio"/>	<input type="radio"/>	<input type="radio"/>	<input type="radio"/>	<input type="radio"/>	<input type="radio"/>	<input type="radio"/>	<input type="radio"/>	<input type="radio"/>	<input type="radio"/>	<input type="radio"/>	<input type="radio"/>	<input type="radio"/>	<input type="radio"/>	Clean the Strainer.	See "Drain Fuel Tank" on page 5-24.

This Page Intentionally Left Blank

This Page Intentionally Left Blank

This Page Intentionally Left Blank

YANMAR®

**Head Office:
Yanmar Co., Ltd.**

1-32 Chayamachi, Kita-ku, Osaka Japan
<http://www.yanmar.co.jp>

Yanmar America Corporation

951 Corporate Grove Drive
Buffalo Grove, IL 60089-4508, U.S.A.
TEL: 1-847-541-1900 FAX: 1-847-541-2161
<http://www.yanmar.com>

Yanmar Europe B.V.

Brugplein11, 1332 BS Almere -de Vaart,
The Netherlands.
TEL: 31-36-5493200 FAX: 31-36-5493209
<http://www.yanmar.nl>

Yanmar Asia (Singapore) Corporation Pte. Ltd.

4 Tuas Lane, Singapore 638613
TEL: 65-68615077 FAX: 65-68611509
<http://www.yanmar.co.jp/yasc/>

YANMAR[®]

YANMAR CO.,LTD.