

Connecting the Valve Wires (Figure 3)

Step 1- Route 18 AWG direct-burial sprinkler cable from the timer to the valves.

Step 2- Using wire splice connectors, attach either wire from each valve solenoid to the white cable wire. This wire is designated as the valve "Common Wire." Connect the remaining wire from the solenoid to one of the color-coded wires.

▲ **Important:** All wire splices must be insulated with grease caps or similar waterproofing devices.

Step 3- At the timer, connect the control wires to the numbered terminals in the desired operating sequence and the valve common wire to the common terminal.

Step 4- Using the timer's manual control feature, test the operation of each valve.

Manual Operation (Figure 4)

• **Bleed Screw** (external bleed): To open the valve, turn the Bleed Screw counterclockwise one full turn or until water begins discharging from the port.

Note: Removing the bleed screw is not required but can be removed to help flush debris from the upper diaphragm area.

To close the valve, turn the bleed screw clockwise until it stops. **Do not over-tighten!**

• **Bleed Handle** (internal bleed): To open the valve, move the Bleed Handle counterclockwise to the stop. To close the valve, move the handle clockwise until resistance is felt. **Do not over-tighten!**

• **Flow Control Adjustment:** With the valve operating, use a small screwdriver to turn the flow control screw clockwise to decrease flow or counterclockwise to increase flow.

Note: The flow control screw requires approximately seven turns to adjust from maximum to minimum flow.

▲ **Caution:** Do not use the flow control to shut off the valve. Do not force the flow control screw past the end of normal adjustment travel. Damage can occur.

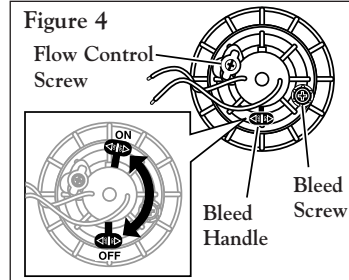
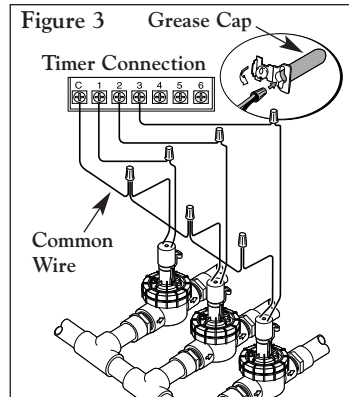

The Toro Promise — Limited One-Year Warranty

The Toro Company and its affiliate, Toro Warranty Company, pursuant to an agreement between them, jointly warrants, to the owner, each new piece of equipment against defects in material and workmanship for the period of one year from the date of purchase.

Neither Toro nor Toro Warranty Company is liable for failure of products not manufactured by them even though such products may be sold or used in conjunction with Toro products.

During such warranty period, we will repair or replace, at our option, any part found to be defective.

Return the defective part to the place of purchase.

Our liability is limited solely to the replacement or repair of defective parts. There are no other express warranties.

This warranty does not apply where equipment is used, or installation is performed, in any manner contrary to Toro's specifications and instructions, nor where equipment is altered or modified.

Neither Toro nor Toro Warranty Company is liable for indirect, incidental or consequential damages in connection with the use of equipment, including but not limited to: vegetation loss, the cost of substitute equipment or services required during periods of malfunction or resulting non-use, property damage or personal injury resulting from installer's negligence.

Some states do not allow the exclusion or limitation of incidental or consequential damages, so the above limitation or exclusion may not apply to you.

All implied warranties, including those of merchantability and fitness for use, are limited to the duration of this express warranty.

Some states do not allow limitations of how long an implied warranty lasts, so the above limitation may not apply to you.

This warranty gives you specific legal rights and you may have other rights which vary from state to state.

TORO

1" In-line Valve Models 53707 and 53709

- Installation Guide -

The Toro 1" in-line electric valves are designed for use in an automatic sprinkler system controlled by a 24 V a.c. sprinkler system timer. The valves feature manual flow control adjustable down to zero flow and manual bleed controls which enable the valve to be operated without the use of the timer. The 53707 valve is designed for slip-fit pipe connections and model 53709 features female-threaded inlet and outlet. These valves are generally installed below grade, grouped with other valves in a manifold arrangement and housed in a protective valve box.

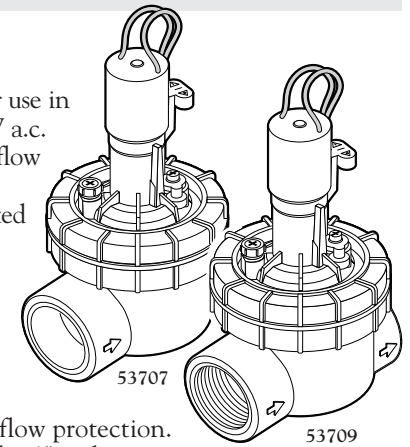

▲ **Important:** These valves do not provide backflow protection.

A backflow prevention device installed between the 1" in-line valve(s) and the water source point of connection is required in most areas to prevent back-siphoning of contaminants through the sprinkler system into the potable water supply. The Toro 1" Pressure Vacuum Breaker (PVB), model number 53300, is specifically designed for this purpose. Before connecting your irrigation system to the potable water supply, consult with your local water utility department for information regarding backflow prevention requirements. Where local water pressure exceeds 70 psi, a pressure regulator should be used. (See Uniform Plumbing Code, Sec. 1007[b].) It is advisable to use a regulator with any automatic valve to assure long life as well as uniform and controllable operation.

Valve Specifications:

Operating Pressure: 20–150 PSI

Flow Range: 0.25–30 GPM

Solenoid:

24 V a.c., 60 Hz (nominal)

19 V a.c., 60 Hz (minimum)

Inrush: 0.40 amps, 9.6 VA @ 24 V a.c., 60 Hz

Holding: 0.20 amps, 4.8 VA @ 24 V a.c., 60 Hz

Friction Loss:

GPM Flow	0.25	5	10	15	20	30
PSI Loss	2.0	3.5	4.0	3.0	3.3	6.2

Installation Procedure

Note: To ensure ease of installation and optimum valve performance, please read through the following instructions completely before starting the installation procedure.

Step 1- Route 1" schedule 40 PVC pipe from the backflow preventer or system shut-off device to the valve location. Flush the supply line thoroughly!

▲ **Caution:** Dirt, rocks and debris entering the valve can damage the valve and/or cause the valve to malfunction.

Step 2- The instructions and illustrations on the next page provide the most commonly recommended methods of installing in-line valves in a manifold arrangement. Use the appropriate step-by-step instruction for the valve model being installed.

• **Model 53707 Installation (Figure 1)**

Step 1- Cut a 4" length of 1" schedule 40 PVC pipe for each valve.

Step 2- Using PVC primer and cement, assemble the pipe section to the valve inlet and tee fitting, aligning the tee perpendicular to the valve. Repeat this procedure for each valve in the manifold.

Note: The last valve in the manifold can be connected with a 90° elbow instead of a tee. However, if future expansion of the sprinkler system is expected, use the tee fitting and a 4" section of 1" schedule 40 PVC pipe capped on the end. This enables the main line to be easily connected to additional downstream valves.

Step 3- Using 4" sections of 1" schedule 40 PVC pipe, connect the valve assemblies together to create the manifold, making sure the valves are aligned during assembly.

Step 4- Ensure the end of the supply line is dry and free of burrs. Cement the manifold to the main line.

Step 5- Allow the cemented connections to cure for a minimum of one hour (or per the cement manufacturer's directions) before applying water pressure. If no leaks occur after pressurization, begin connecting the sprinkler zone piping using 1" class 200 PVC pipe.

• **Model 53709 Installation (Figure 2)**

Step 1- Apply three complete wraps of PTFE tape to the slip/thread adapters.

▲ Caution: Use only PTFE tape on threaded connections. Pipe dope and other types of pipe thread sealants can damage plastic threads.

Step 2- Install a slip/thread adapter into each end of the valve and tighten securely.

Step 3- Cut a 4" length of 1" schedule 40 PVC pipe for each valve.

Step 4- Using PVC primer and cement, assemble the valve and PVC components as shown, aligning the tee fitting perpendicular to the valve. Repeat this procedure for each valve in the manifold.

Note: The last valve in the manifold can be connected with a 90° elbow instead of a tee. However, if future expansion of the sprinkler system is expected, use the tee fitting and a 4" section of 1" schedule 40 PVC pipe capped on the end. This enables the main line to be easily connected to additional downstream valves.

Step 5- Using 4" sections of 1" schedule 40 PVC pipe, connect the valve assemblies together to create the manifold, making sure the valves are aligned during assembly.

Step 6- Ensure the end of the supply line is dry and free of burrs. Cement the manifold to the main line.

Step 7- Allow the cemented connections to cure for a minimum of one hour (or per the cement manufacturer's directions) before applying water pressure. If no leaks occur after pressurization, begin connecting the sprinkler zone piping using 1" class 200 PVC pipe.

Figure 1

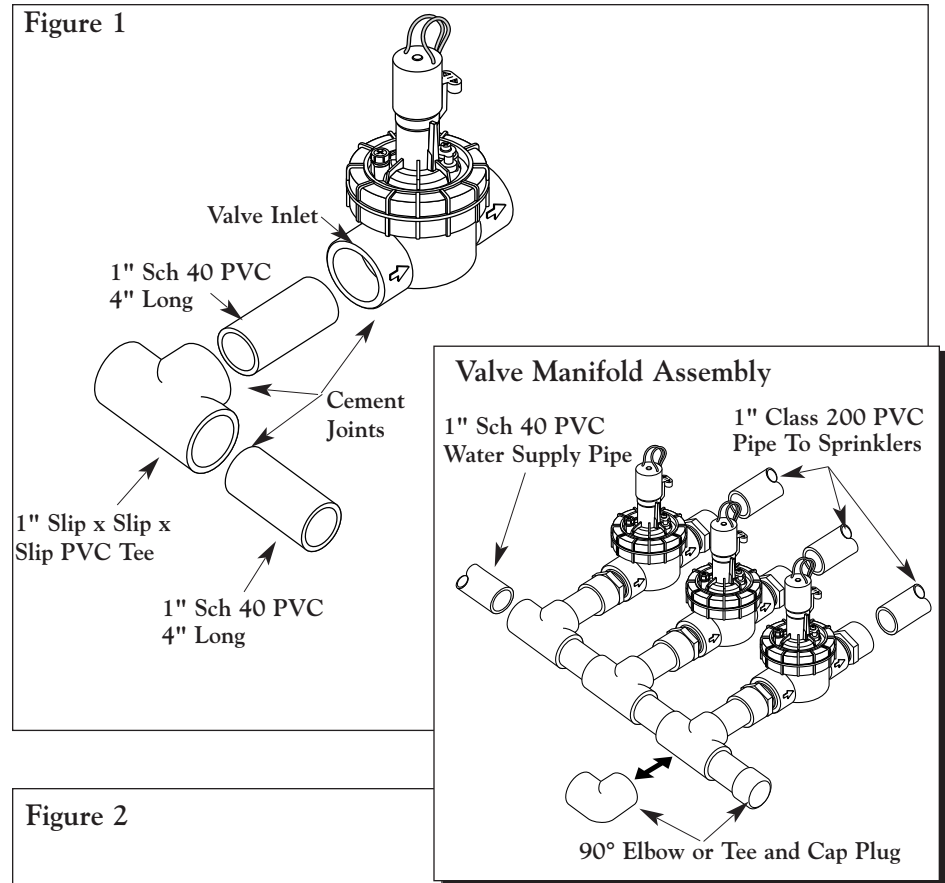

Figure 2

