

The 720G part circle model is factory preset to 3 GPM, 180° arc and 25° trajectory. The full circle model is preset to 6 GPM, 360° arc and 25° trajectory. To adjust these settings, use the following procedures.

## 1 Adjust Flow

Flow is adjustable from 1 to 9 GPM

• Part Circle - Factory preset to 3 GPM

• Full Circle - Factory preset to 6 GPM

► **Tip** – Flow adjustment can be made wet or dry.

1. Insert edge of Toro tool (provided) into slot of flow adjust ring.
2. While holding top of nozzle with thumb, turn flow adjust ring in either direction to align arrow with desired flow rate number.

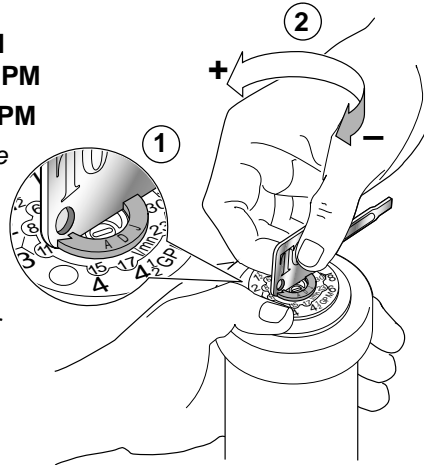

## 2 Adjust Arc (part circle models only)

Arc is adjustable from 40° to 360°

• Factory preset to 180°

• Only right side of arc is adjustable

► **Tip** – Arc can be adjusted wet or dry. **Turn nozzle to left stop before changing arc.**

1. Insert Toro tool into small slot in nozzle top.
2. To **increase** arc, turn tool **clockwise**.  
To **decrease** arc, turn tool **counterclockwise**.

► **Tip** – Full turn changes arc 180°; half turn changes arc 90°.

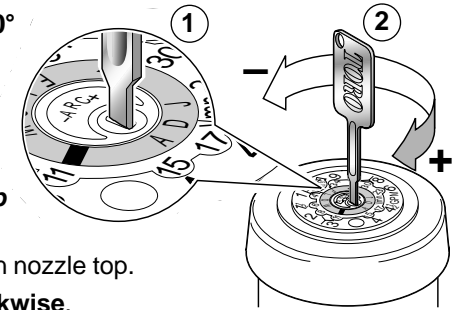

## 3 Install Sprinkler and Check Arc Setting

1. Install and tighten sprinkler onto a 3/4" threaded fitting aligning arrow on cover with left watering border.
2. To check arc setting during operation, turn nozzle in direction of rotation, releasing just before end of arc – observe reversing point. To quickly change direction of rotation, turn nozzle slightly beyond the arc border to actuate the reversing mechanism.
3. Fine tune arc setting by turning arc adjustment slot right to increase or left to decrease.

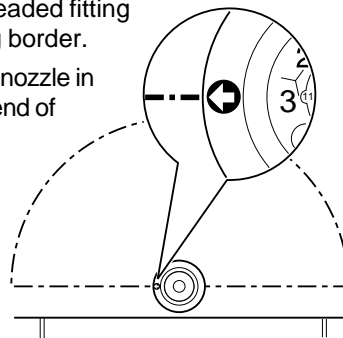

## 4 Adjust Radius/Trajectory

Trajectory is adjustable from 7° to 25°

• Factory preset to 25°

1. Insert Toro tool through radius adjustment hole in top of nozzle cover.
2. To **decrease** (–), turn tool **clockwise** (7° minimum).

To **increase** (+), turn tool **counterclockwise** (25° maximum).

► **Tip** – 7° setting is not recommended for newly seeded areas.

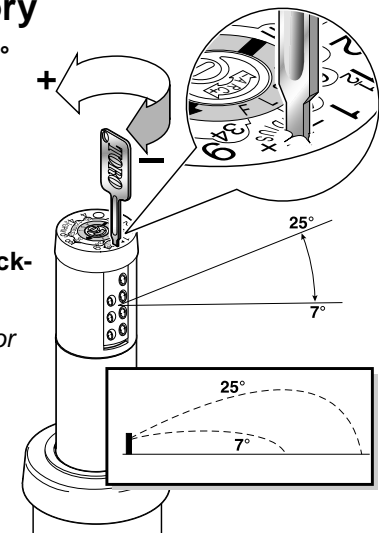

## Specifications

- Pressure Range: 40–100 psi
- Optimum Pressure: 65 psi
- Arc Range: 40°–360° (Part Circle Models)
- Nozzle Trajectory: 7°–25°
- Inlet Size: 3/4"

\***Note:** Precipitation rates are calculated at 55% of diameter for triangular (▲) spacing and 50% of diameter for square (■) spacing.

## Sprinkler Performance (@ 65 psi & 25° trajectory)

Flow Adj. GPM	Pressure PSI	Radius feet	Flow GPM	Precipitation Rate*	
				▲ in/hr	■ in/hr
1	65	29	1.39	0.14	0.16
1.5	65	30	1.91	0.18	0.20
2	65	31	2.63	0.23	0.26
3	65	32	3.42	0.28	0.32
4	65	35	4.69	0.32	0.37
4.5	65	36	5.41	0.35	0.40
6	65	39	6.87	0.38	0.43
8	65	42	8.61	0.41	0.47
9	65	44	9.67	0.42	0.48

## Disassembly

### 1 Remove Rubber Cover

1. Grasp lower edge of rubber cover and pull away from lip of body as shown.

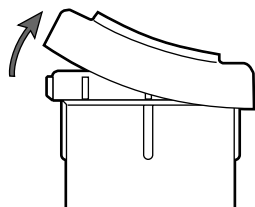

### 2 Remove Snap Ring

1. Insert Toro tool into snap ring slot until gray interlocking ring beneath snap ring is pressed down.
2. With twisting motion, disengage snap ring from body.
3. Twist snap ring out.
4. Remove sprinkler assembly from body.

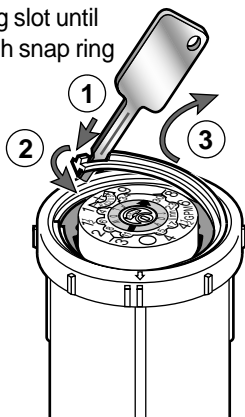

## Reassembly

### 1 Install Sprinkler Assembly

1. To maintain left side arc alignment of part circle sprinkler, position alignment keys as shown.
2. Insert sprinkler assembly into body.

Alignment Keys

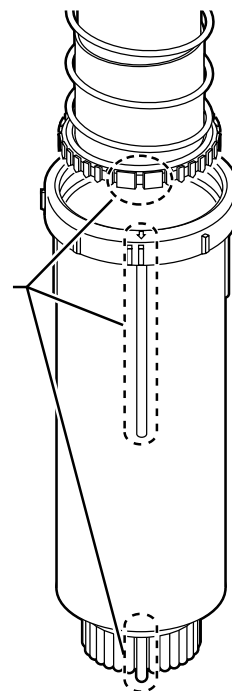

### 2 Install Snap Ring

1. Place snap ring into body with beveled side down.

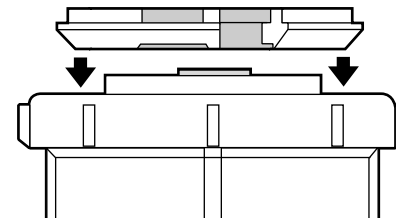

**CAUTION:** Snap ring must be properly installed in body groove and with gray interlocking ring as shown to ensure retention of sprinkler assembly.

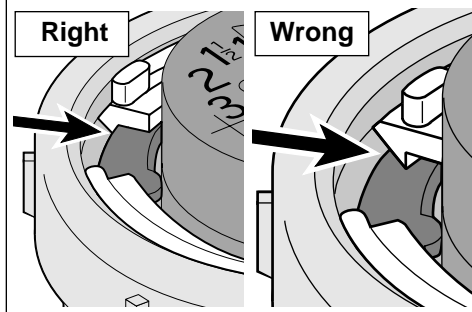

### 3 Install Rubber Cover

1. For part circle sprinkler, align arrow on cover with alignment keys on body as shown.
2. Push cover onto lip of body to secure.

